

**F1356 - F1357 - F1372 - F1150 - F1358 - F1489**

Concealed Mixers - Guidelines Page 2

Indbygningsarmatur - Vejledning Side 8

Verdeckte Mischer - Installationshinweise Seite 14

Mitigeurs encastrés - Instructions Page 20

Miscelatori interni - Indicazioni Pag. 26

Mezcladores empotrados - Directrices Página 32

Misturadoras ocultas - Instruções Página 38

Inbouwmengkranen - Richtlijnen Pagina 44

1. Cleaning of mixers

The surface and function of each mixer have been inspected and checked one by one, before they leave the Factory.

To protect and preserve the surface, please follow below instructions:

Chrome surfaces

as well as polished brass surfaces should be cleaned with a soft cloth and liquid, acid-free cleaning materials without abrasive, or with soap water.

Lime residues

can be removed with common household vinegar.

Coloured enamel surfaces

will lose their shiny look if cleaned with materials containing abrasive. Use only clean water or diluted detergent. Lime residues can be removed with common household vinegar.

Aerators

Lime in aerators: Put the aerator in household vinegar and let it soak, until the lime dissolves.

2. Dimensions

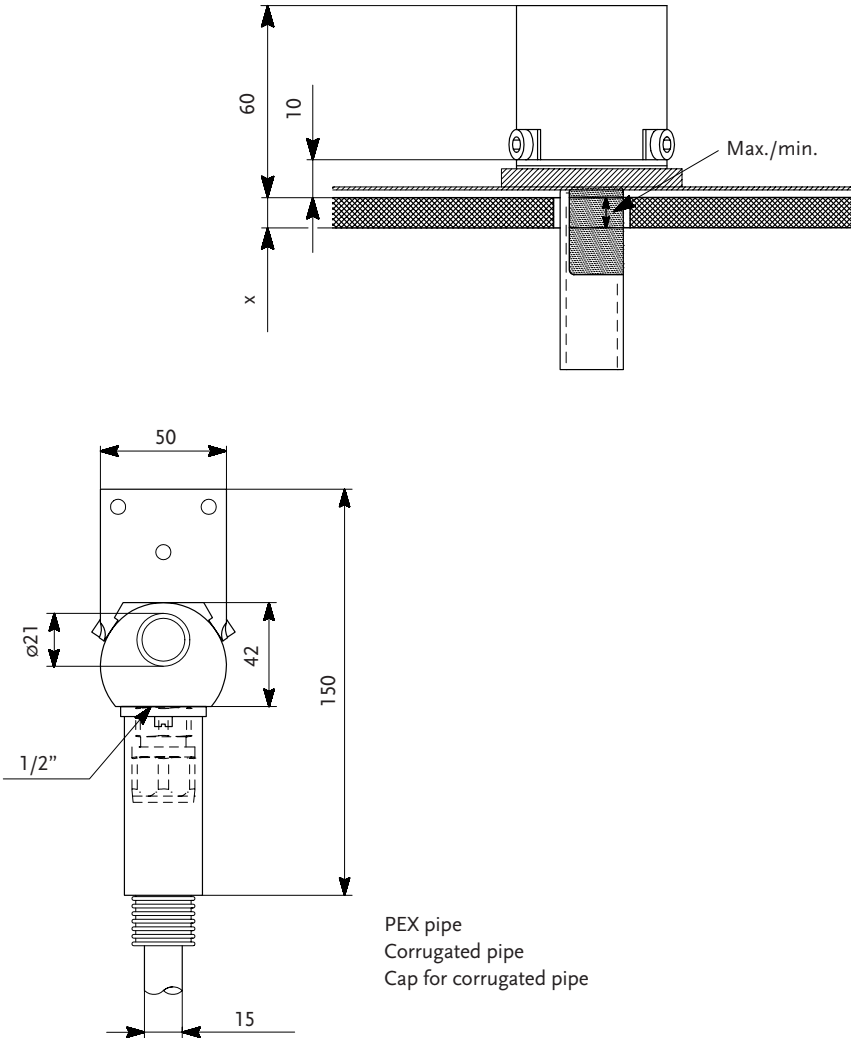

2. Dimensions

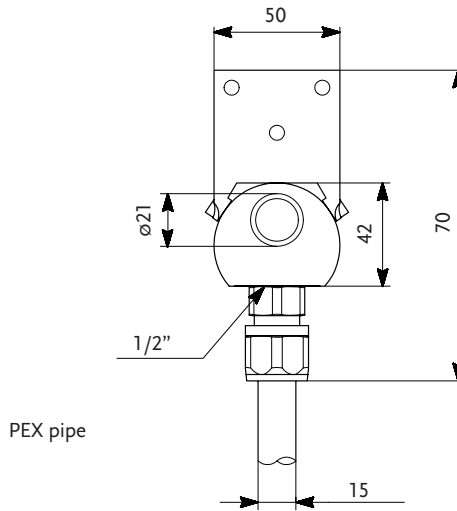
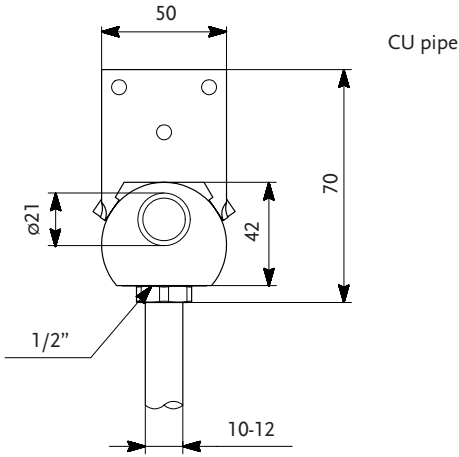

3. Extension kits

Standard thickness of wall covering = 3 - 13 mm.

In case of a thicker wall covering the spindle can be extended (see below table):

Tile thickness (x)	Dimension from spindle end to outside surface of wall (y)	Mixer type					
		F1356 F1357 F1358 F1489	F1372 F1150				
3 - 13 mm	44 - 54 mm	Standard	Standard				
13 - 23 mm	34 - 44 mm	F960138NU	F960453NU				
23 - 33 mm	24 - 34 mm	F960139NU	F960743NU				
33 - 43 mm	14 - 24 mm	F960140NU	F960744NU				
43 - 53 mm	4 - 14 mm	F960141NU	F960745NU				

4. Guidelines for mounting of concealed mixers in lightweight wall (18 mm or 2 x 13 mm)

Cut-out, lightweight wall - 18 mm
 Cut-out, lightweight wall - 2 x 13 mm

1

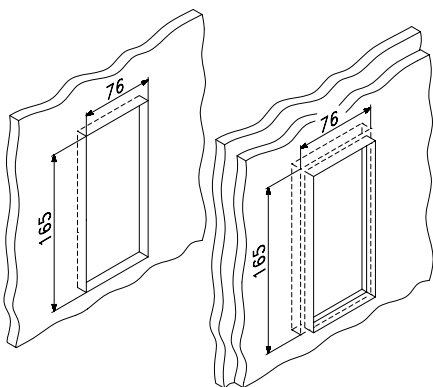

Coating - 1st time under rubber membrane

4

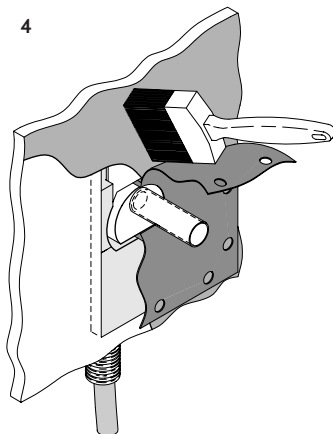

1/2" connection for copper tubes, plastic tubes,
 or steel tubes and assembly of styrenbox

Coating - 2nd time over rubber membrane

2

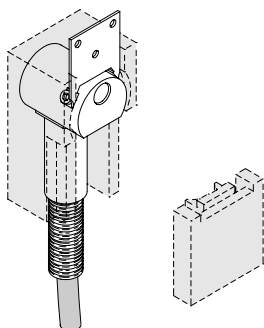

5

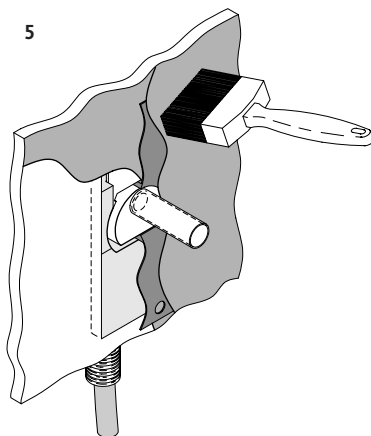

Walling up with membrane

Wall covering, e.g. tiling

3

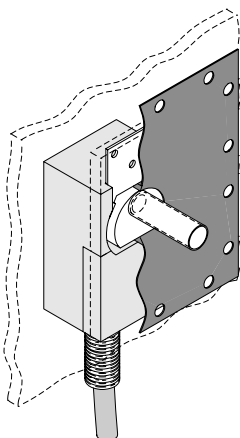

6

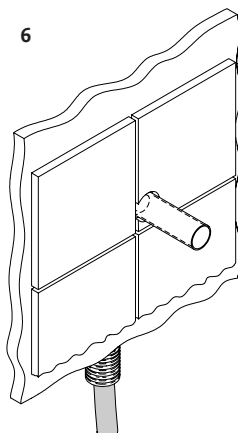

5. Guidelines for mounting of concealed mixers in brick wall

1 Cut-out, brickwork

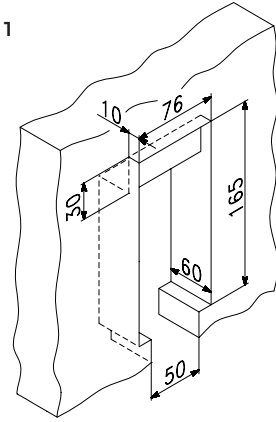

4 Coating - 1st time under rubber membrane

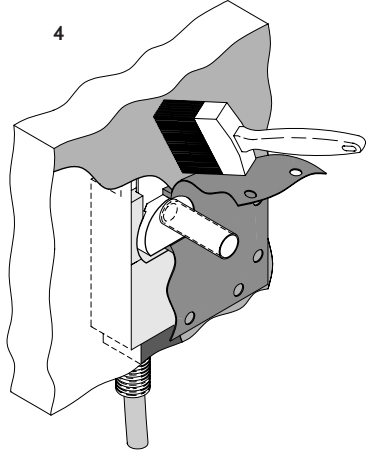

1/2" connection for copper tubes, plastic tubes (PEX pipe), or steel tubes

2

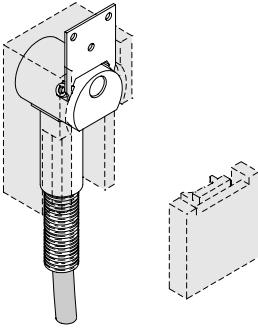

Coating - 2nd time over rubber membrane

5

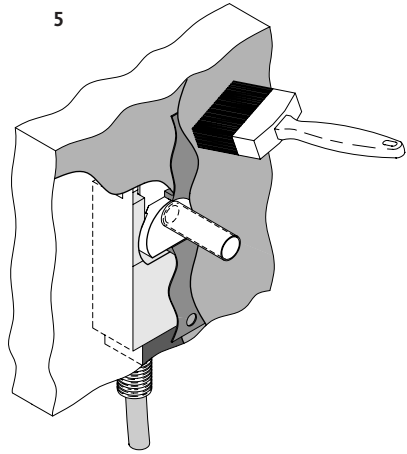

3 Walling up with membrane

3

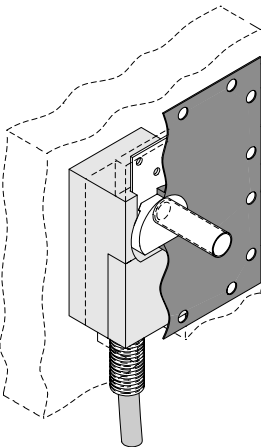

6 Wall covering, e.g. tiling

6

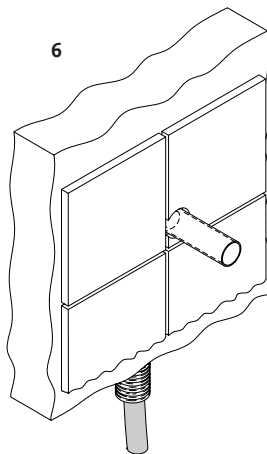

6. Final assembly

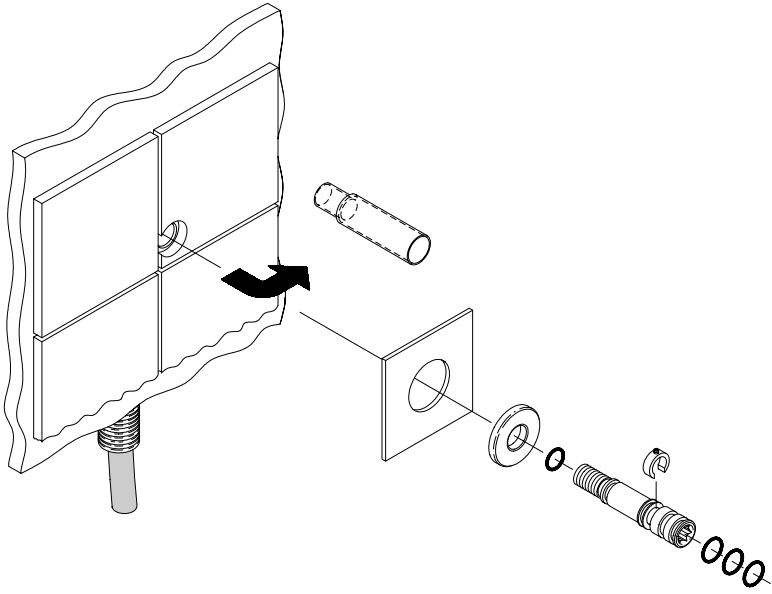

7. Exploded view

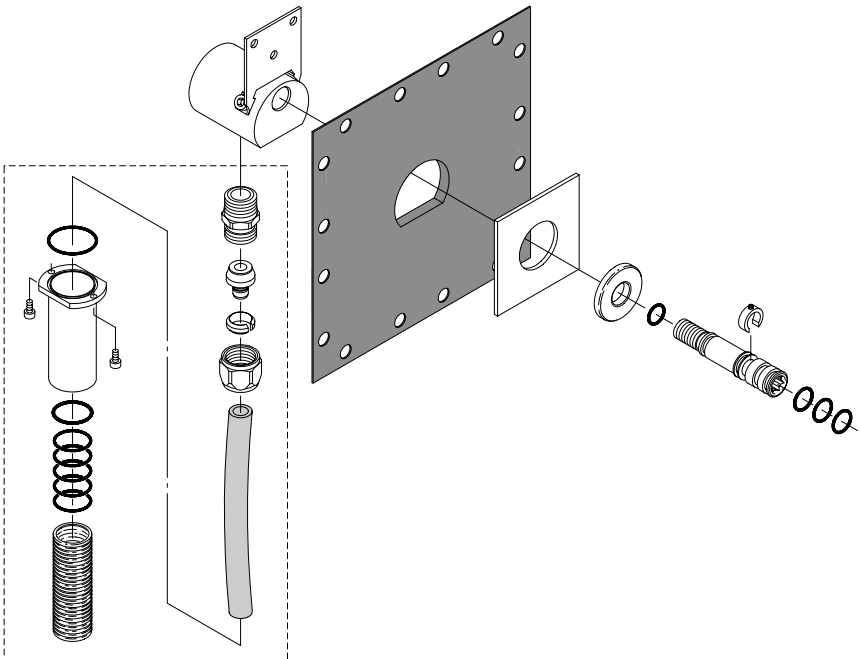

Accessories not included!

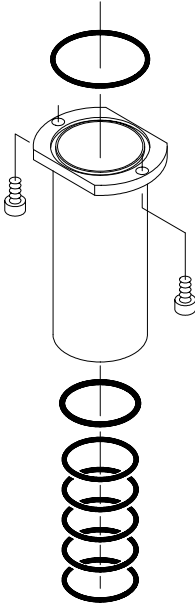

Accessorie for corugated pipe

No. of cap sets needed		Article No.
	F960747NU	F1356
		F1357
1 x		F1372
		F1150
		F1358
		F1489

Above-mentioned accessory kit is suitable for all connections of a given model.

Example: 1 x accessory kit F960747NU for e.g. F1356 includes all necessary connections.

1. Rengøring af blandingsbatterier

Hvert blandingsbatteris overflade og funktion efterses og kontrolleres enkeltvis, før de forlader fabrikken.

Følg nedenstående vejledning for at beskytte og bevare overfladen:

Kromoverflader

samt polerede messingoverflader rengøres med en blød klud og væske, syrefri rengøringsmidler uden slibemiddel, eller med sæbevand.

Kalkaflejringer

kan fjernes med almindelig husholdningseddike.

Farvede lakoverflader

mister deres skinnende udseende, hvis de rengøres med midler, der indeholder slibemiddel. Brug kun rent vand eller fortyndet rengøringsmiddel. Kalkaflejringer kan fjernes med almindelig husholdningseddike.

Luftblander

Kalk i luftblander: Anbring luftblanderen i husholdningseddike, og lad den ligge i blød, indtil kalken er opløst.

2. Mål

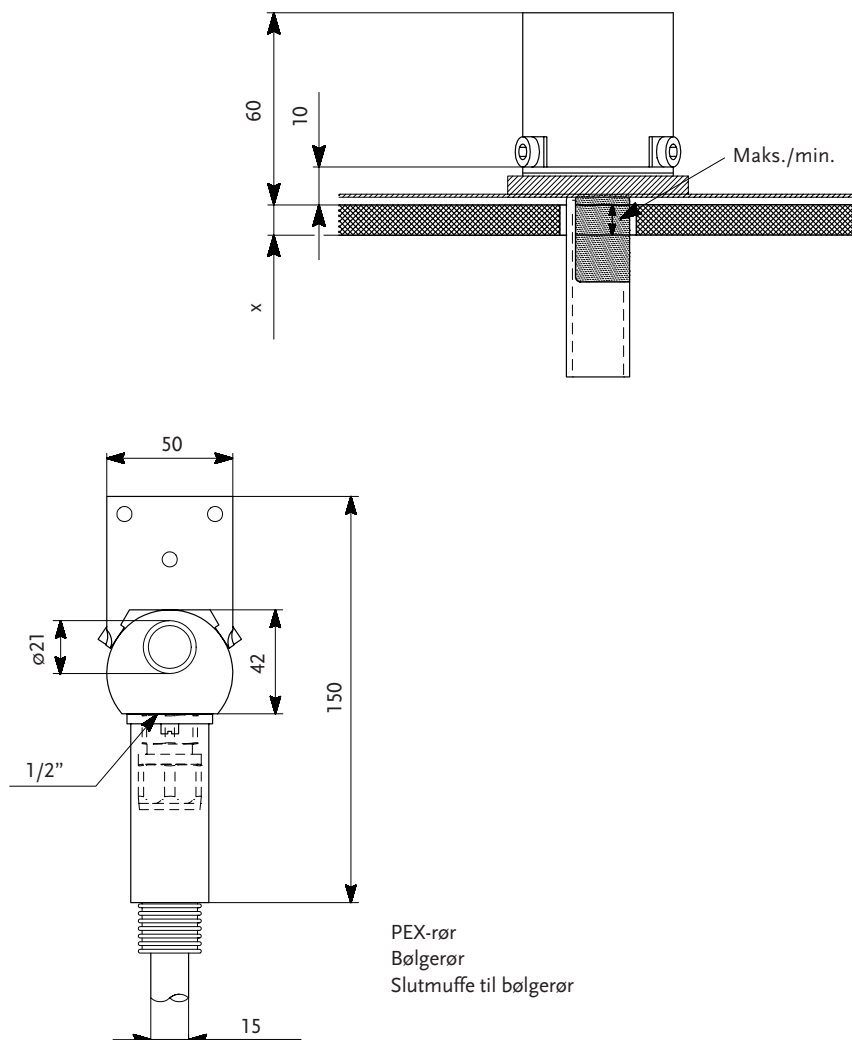

2. Mål

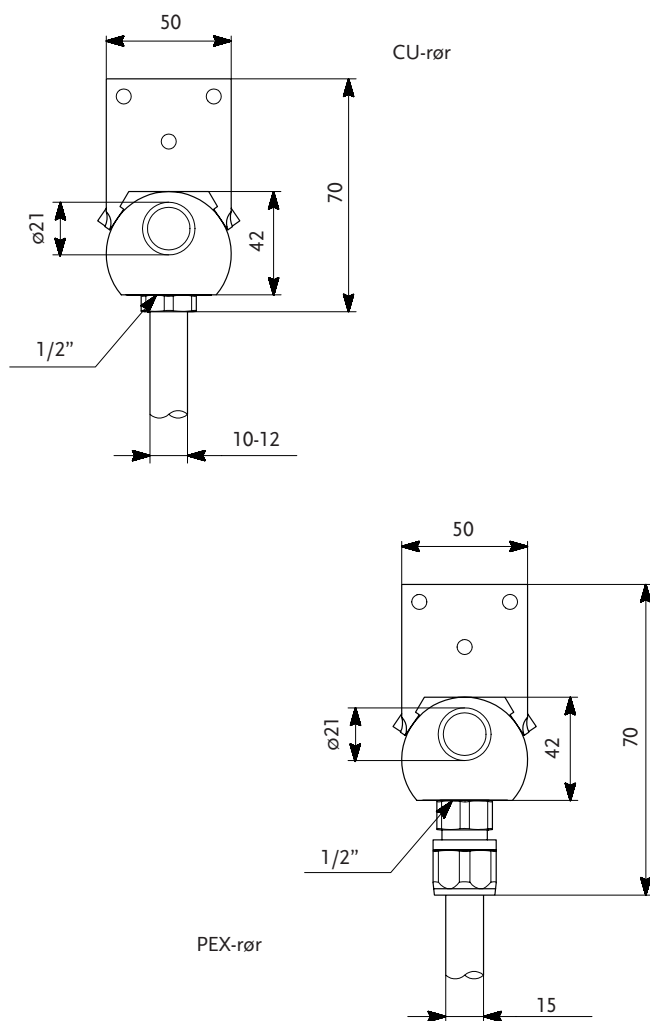

3. Forlængersæt

Vægbeklædningens standardtykkelse = 3 - 13 mm.

I tilfælde af tykkere vægbeklædning kan spindelen forlænges (se nedenstående tabel):

Flisetykkelse (x)	Mål fra spindel- enden til væg- gens overflade på ydersiden (y)	Blandingsbatteri - type					
		F1356 F1357 F1358 F1489	F1372 F1150				
3 - 13 mm	44 - 54 mm	Standard	Standard				
13 - 23 mm	34 - 44 mm	F960138NU	F960453NU				
23 - 33 mm	24 - 34 mm	F960139NU	F960743NU				
33 - 43 mm	14 - 24 mm	F960140NU	F960744NU				
43 - 53 mm	4 - 14 mm	F960141NU	F960745NU				

4. Vejledning til montering af skjulte blandingsbatterier i letvægtsvæg (18 mm eller 2 x 13 mm)

Udskæring, letvægtsvæg - 18 mm
 Udskæring, letvægtsvæg - 2 x 13 mm

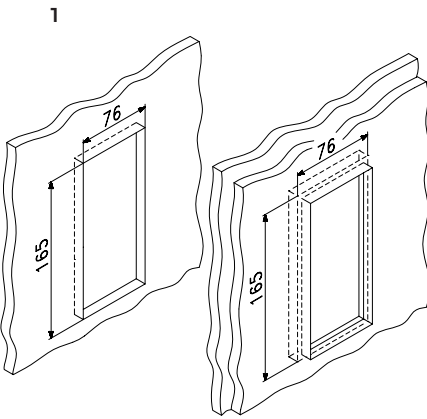

Bestrygning - 1. gang under gummimembranen

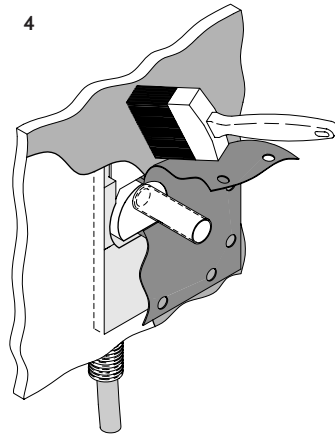

1/2" tilslutning til kobberør, plasticrør eller stålør og samling af styrendåse

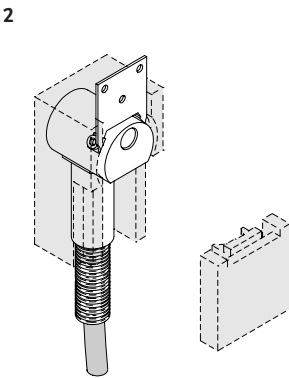

Bestrygning - 2. gang over gummimembranen

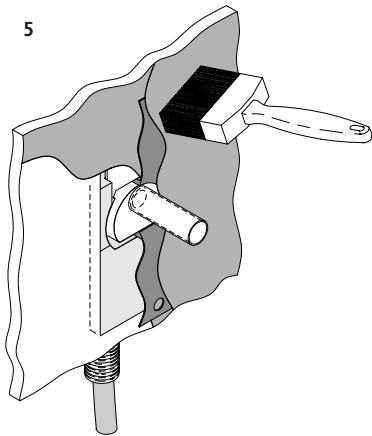

Tilmuring med membran

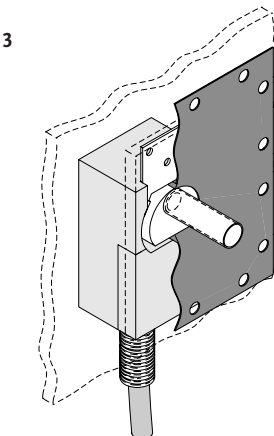

Vægbeklædning, f.eks. fliser

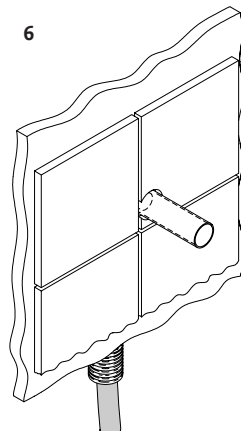

5. Vejledning til montering af skjulte blandingsbatterier i murstensvæg

Udskæring, murværk

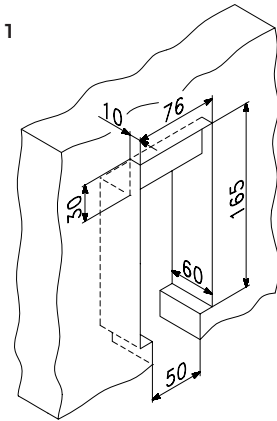

Bestrygning - 1. gang under gummimembranen

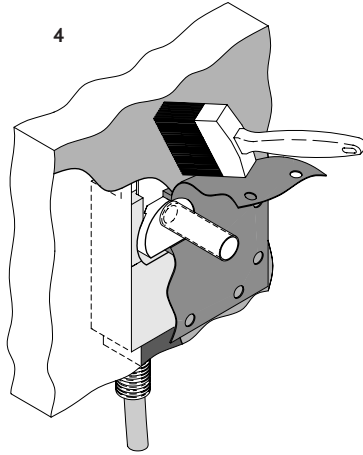

1/2" tilslutning til kobberrør, plasticrør (PEX-rør) eller stålrør

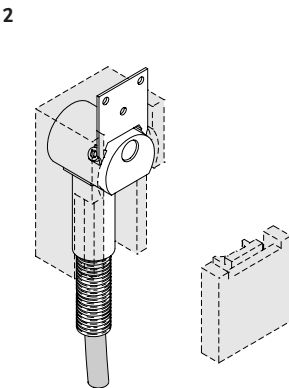

Bestrygning - 2. gang over gummimembranen

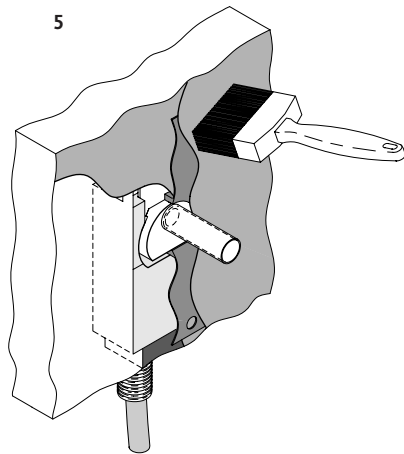

Tilmuring med membran

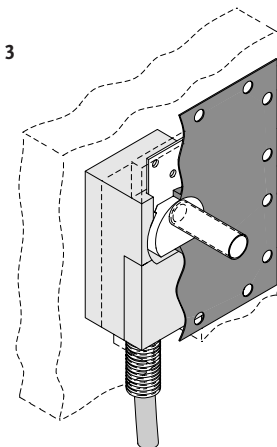

Vægbeklædning, f.eks. fliser

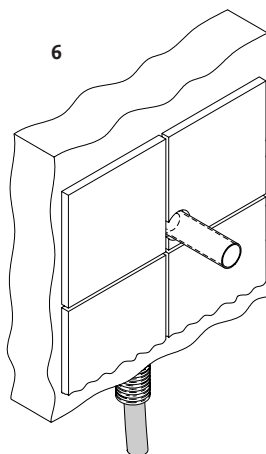

6. Slutsamling

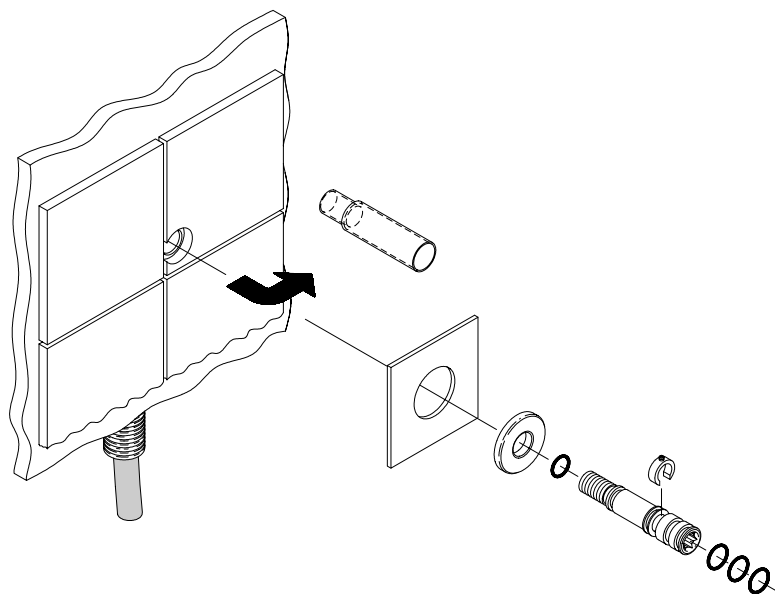

7. Sprængbillede

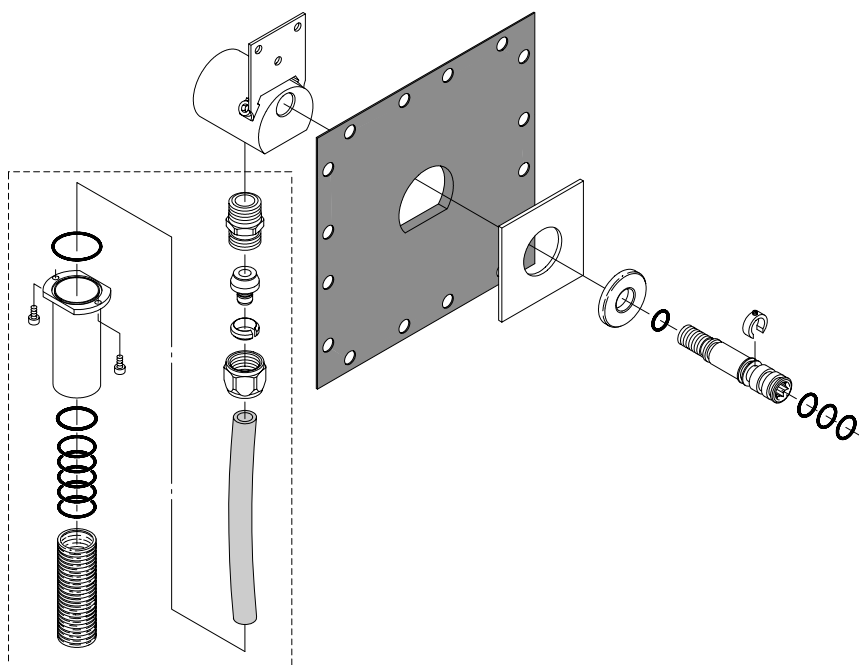

Tilbehør medfølger ikke!

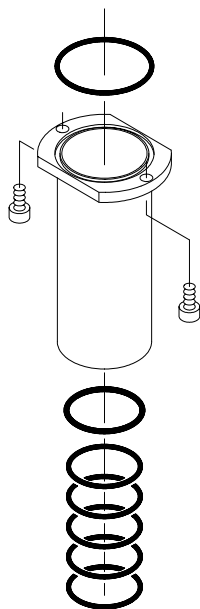

Tilbehør til bølgerør

Antal nødvendige slutmuffer		Artikel nr.
	F960747NU	F1356
		F1357
1 x		F1372
		F1150
		F1358
		F1489

Ovennævnte tilbehørssæt er egnet til alle tilslutninger af en given model.

Eksempel: 1 x tilbehørssættet F960747NU til f.eks. F1356 indeholder alle nødvendige tilslutninger.

1. Reinigung der Mischer

Oberfläche und Funktion jedes einzelnen Mischers wurden vor der Auslieferung ab werk durchgeprüft.

Zum Schutz der Oberfläche beachten Sie bitte die folgenden Hinweise:

Chromoberflächen

und polierte Messingoberflächen müssen mit einem weichen Tuch und säurefreien Flüssigreinigern ohne Scheuermittel bzw. mit einer Seifenlauge gesäubert werden.

Kalkrückstände

können mit haushaltsüblichem Essig entfernt werden.

Farbige Emailoberflächen

verlieren ihren Glanz, wenn sie mit scheuernden Reinigern gesäubert werden. Benutzen Sie nur reines Wasser oder verdünntes Reinigungsmittel. Kalkrückstände können mit haushaltsüblichem Essig entfernt werden.

Belüfter

Kalk in Belüftern: Weichen Sie den Belüfter in haushaltsüblichem Essig ein, bis sich der Kalk löst.

2. Maße

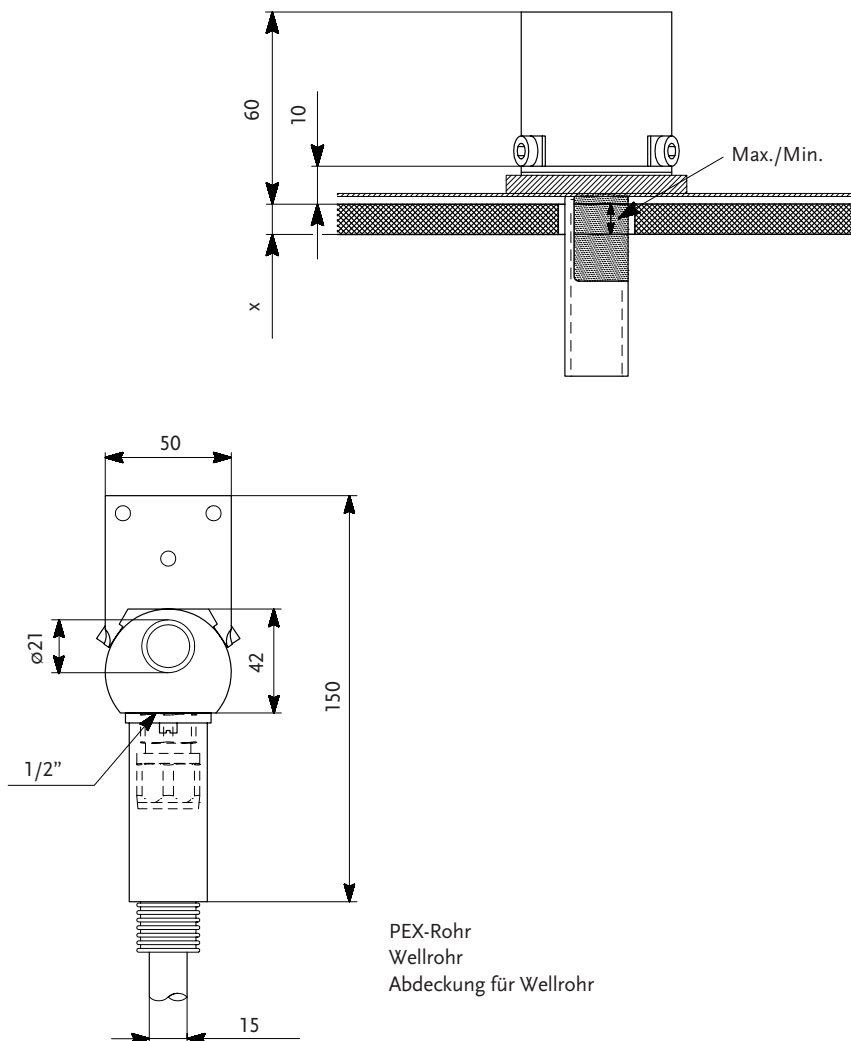

2. Maße

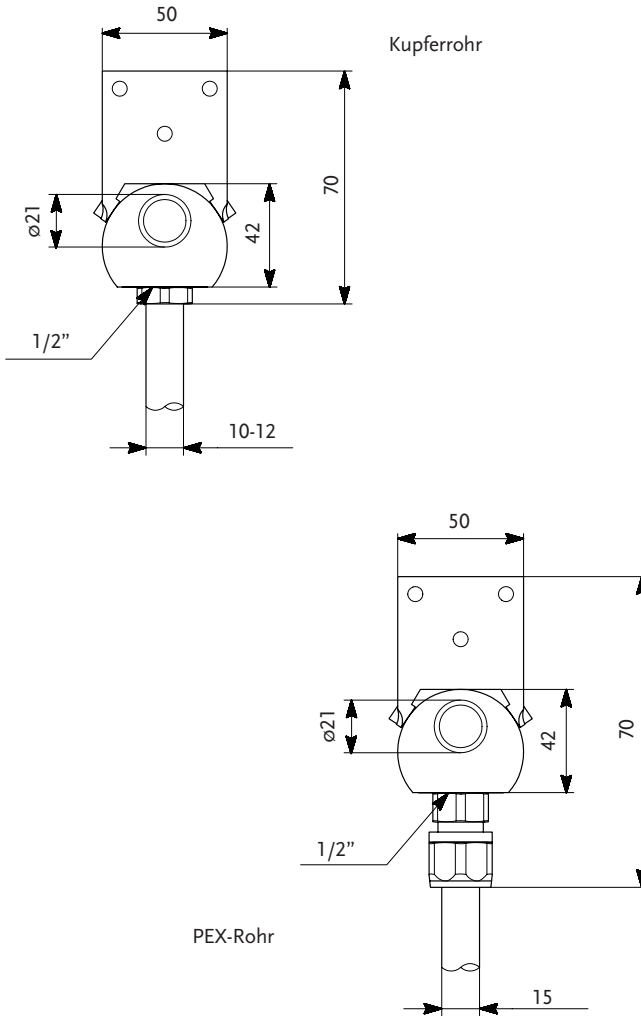

3. Verlängerungssätze

Standardstärke der Wandbedeckung = 3 - 13 mm.

Bei stärkeren Wandbedeckungen kann die Spindel verlängert werden (siehe nachstehende Tabelle):

Fliesenstärke (x)	Maß von Spindelende zu äußerer Wand- oberfläche (y)	Mischertyp			
		F1356 F1357 F1358 F1489	F1372 F1150		
3 - 13 mm	44 - 54 mm	Standard	Standard		
13 - 23 mm	34 - 44 mm	F960138NU	F960453NU		
23 - 33 mm	24 - 34 mm	F960139NU	F960743NU		
33 - 43 mm	14 - 24 mm	F960140NU	F960744NU		
43 - 53 mm	4 - 14 mm	F960141NU	F960745NU		

4. Installationshinweise für verdeckte Mischer in Leichtbauwänden (18 mm bzw. 2 x 13 mm)

Ausschnitt, Leichtbauwand - 18 mm
 Ausschnitt, Leichtbauwand - 2 x 13 mm

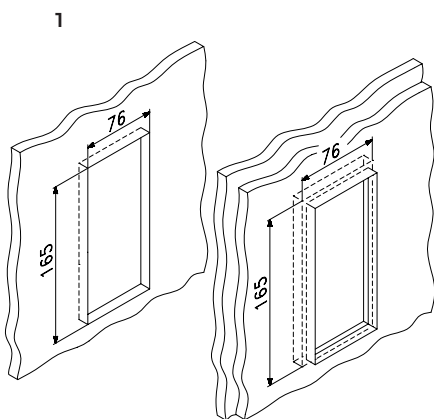

Beschichtung - 1. unter Gummimembrane

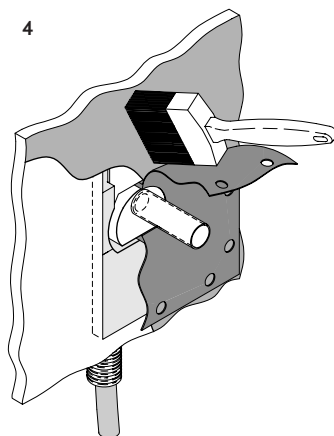

1/2"- Anschluss für Kupfer-, Kunststoff- oder
 Stahlrohre und Styrolbox

Beschichtung - 2. über Gummimembrane

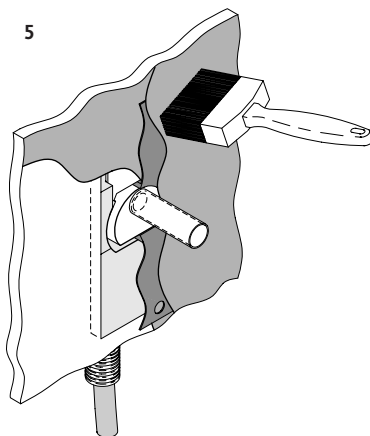
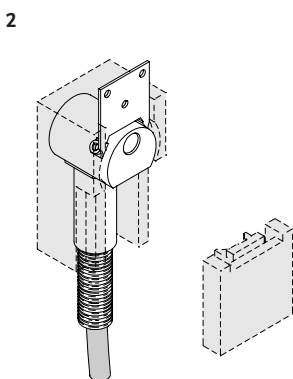

Wandangleichung an Membrane

Wandbedeckung, z.B. Fliesen

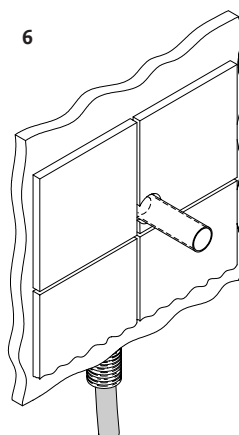
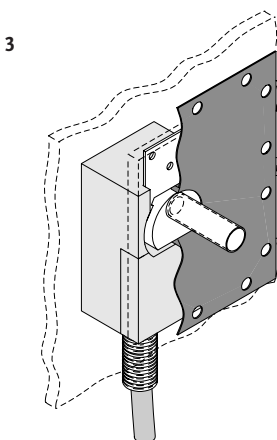

5. Installationshinweise für verdeckte Mischer in gemauerten Wänden

Ausschnitt, Mauerwerk

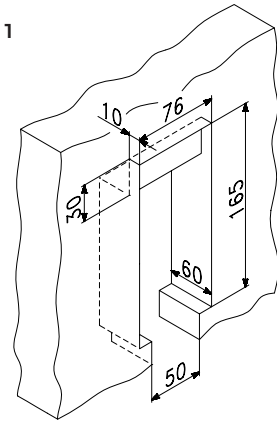

Beschichtung - 1. unter Gummimembrane

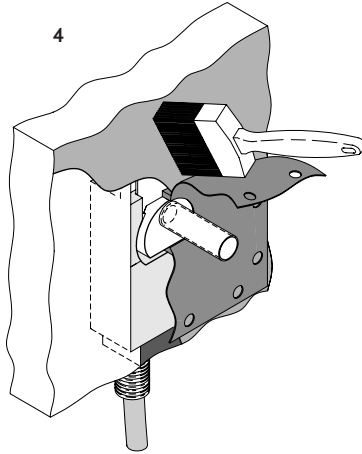

1/2"- Anschluss für Kupfer-, Kunststoff- (PEX-) oder Stahlrohre

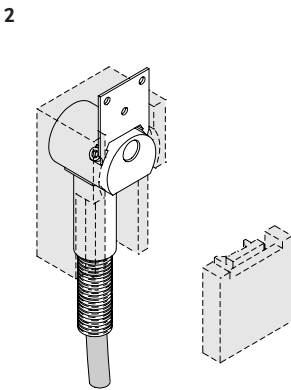

Beschichtung - 2. über Gummimembrane

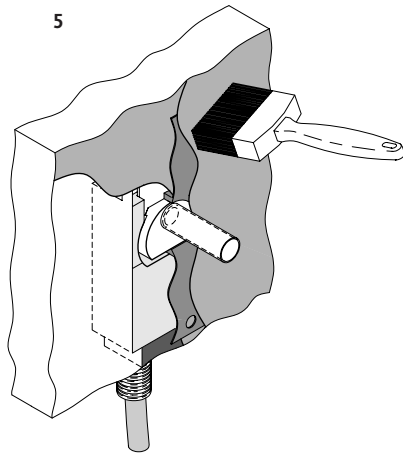

Wandangleichung an Membrane

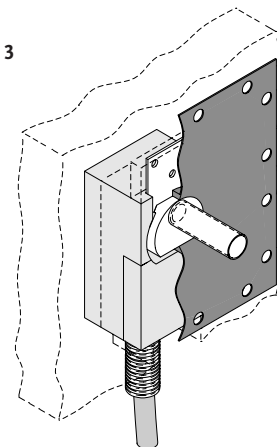

Wandbedeckung, z.B. Fliesen

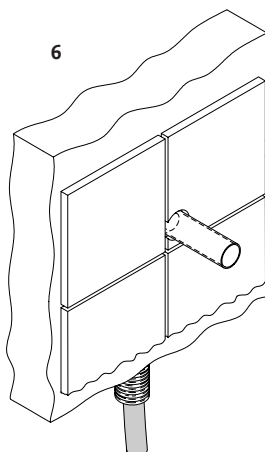

6. Montage

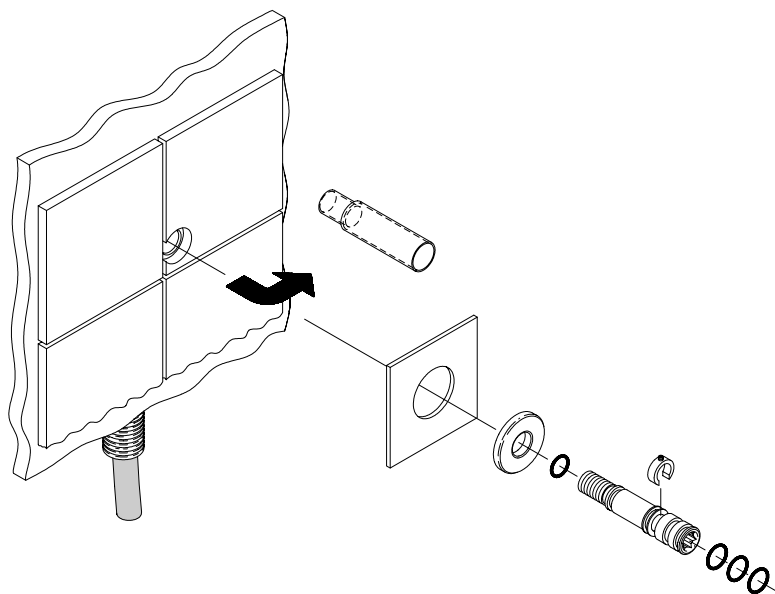

7. Explosionsansicht

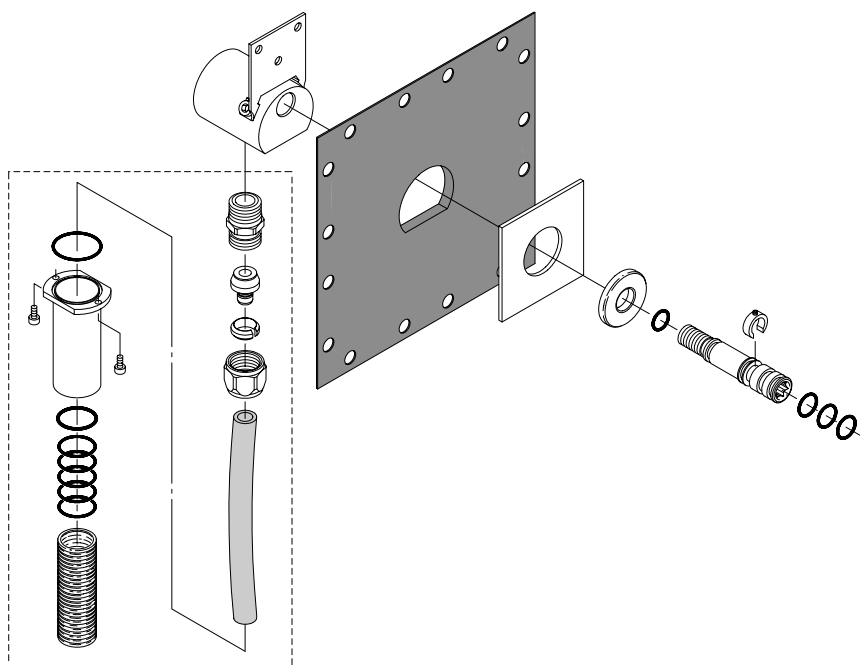

Zubehör nicht im Lieferumfang!

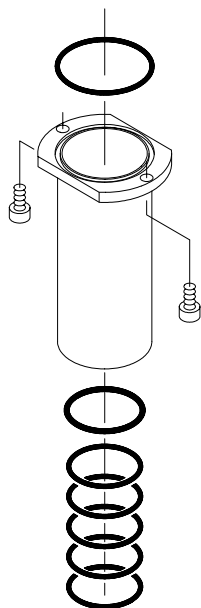

Zubehör für Wellrohr

Anzahl der benötigten Abdeckungsätze		Artikel-Nr.
		F1356
		F1357
1 x	F960747NU	F1372
		F1150
		F1358
		F1489

Der obige Zubehörsatz eignet sich für alle Anschlüsse eines bestimmten Modells.

Beispiel: 1 x Zubehörsatz F960747NU für z.B. F1356 enthält alle notwendigen Anschlüsse.

1. Nettoyage des mélangeurs

La surface et le bon fonctionnement de chaque robinetterie ont été vérifiés et contrôlés individuellement avant de quitter de l'usine. Afin de protéger et de conserver la surface en bon état, il est nécessaire de suivre les instructions indiquées ci-dessous :

Surfaces chromées

Il convient de nettoyer ces surfaces ainsi que le laiton poli avec un chiffon doux et un détergent liquide non acide et non abrasif ou bien avec de l'eau savonneuse.

Résidus de calcaire

S'enlèvent à l'aide de vinaigre de ménage.

Surfaces laquées couleurs

En cas d'utilisation de détergent contenant un abrasif, ces surfaces perdent leur brillance. N'utiliser que de l'eau propre ou du détergent dilué. Retirer les résidus de calcaire à l'aide de vinaigre de ménage.

Aérateurs

Calcaire dans les aérateurs : mettre l'aérateur dans du vinaigre de ménage et le laisser tremper jusqu'à ce que le calcaire soit dissout.

2. Dimensions

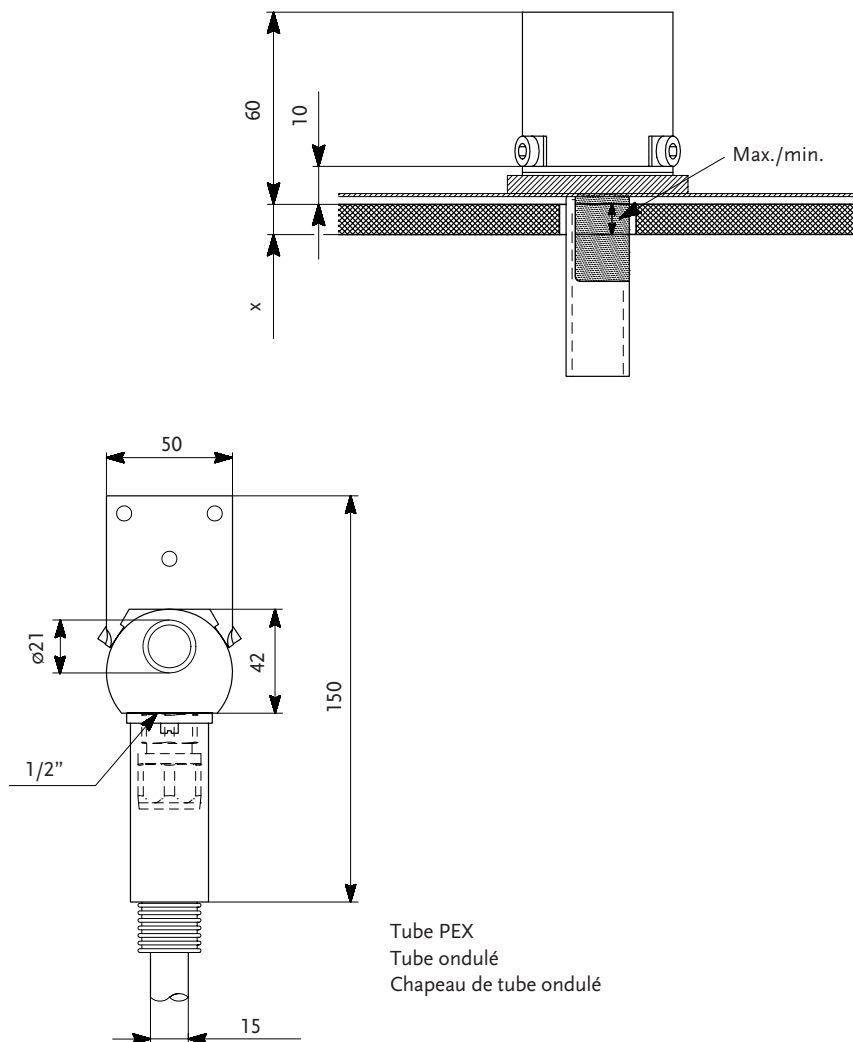

2. Dimensions

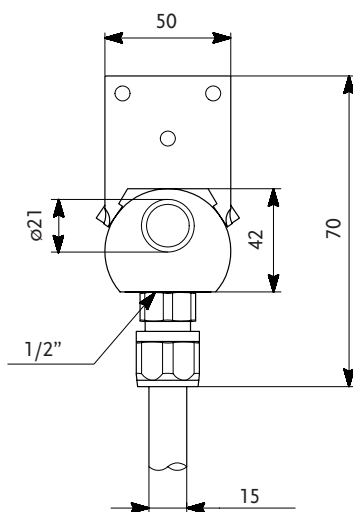
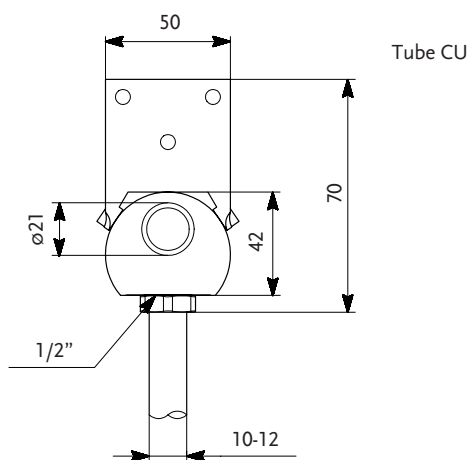

3. Kits d'extension

Épaisseur standard du revêtement mural = de 3 à 13 mm.

En cas de revêtement mural plus épais, une extension de la tige est possible (voir tableau ci-dessous) :

Épaisseur de carreau (x)	Distance de l'extrémité de la tige à la surface extérieure de mur (y)	Type de mélangeur					
		F1356 F1357 F1358 F1489	F1372 F1150				
3 - 13 mm	44 - 54 mm	Standard	Standard				
13 - 23 mm	34 - 44 mm	F960138NU	F960453NU				
23 - 33 mm	24 - 34 mm	F960139NU	F960743NU				
33 - 43 mm	14 - 24 mm	F960140NU	F960744NU				
43 - 53 mm	4 - 14 mm	F960141NU	F960745NU				

4. Instructions de pose de mélangeurs encastrés dans un mur de construction légère (18 mm ou 2 x 13 mm)

Saignée, mur de construction légère - 18 mm
Saignée, mur de construction légère - 2 x 13 mm

Enrobage - 1^{ère} fois sous membrane caoutchouc

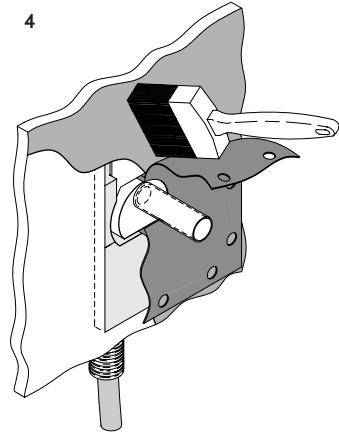
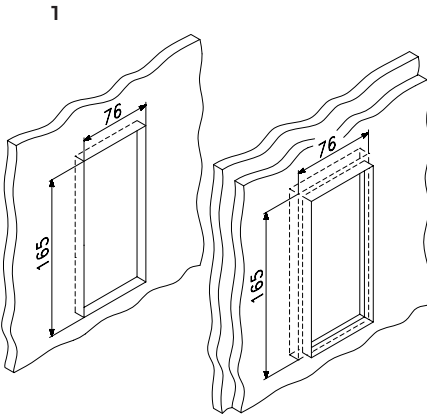

Raccordement 1/2" pour tubes en cuivre, tubes en plastique ou tubes en acier et assemblage de la coque en styrène

Enrobage - 2^{ème} fois sur membrane caoutchouc

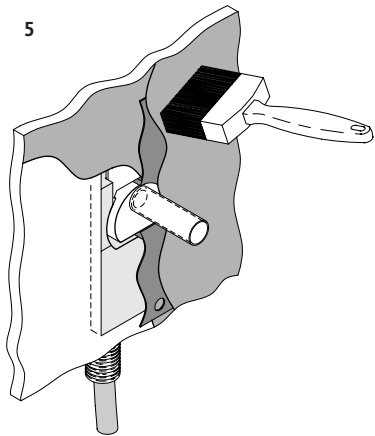
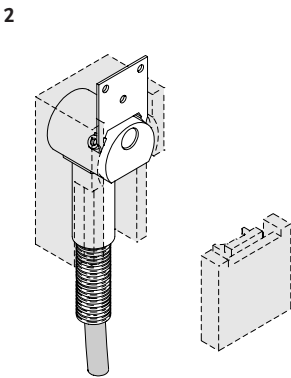

Scellement avec membrane

Revêtement mural, par ex. carrelage

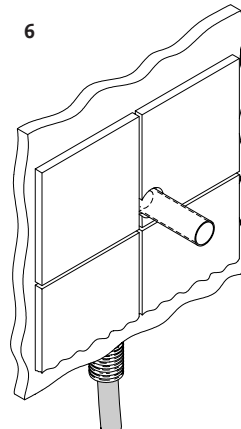
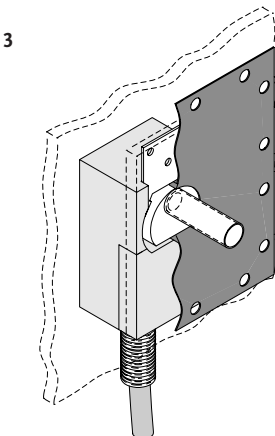

5. Instructions de pose de mélangeurs encastrés dans un mur en briques

Saignée, maçonnerie de brique

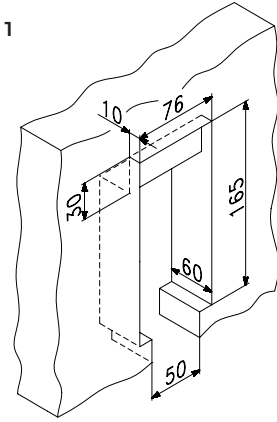

Enrobage - 1^{ère} fois sous membrane caoutchouc

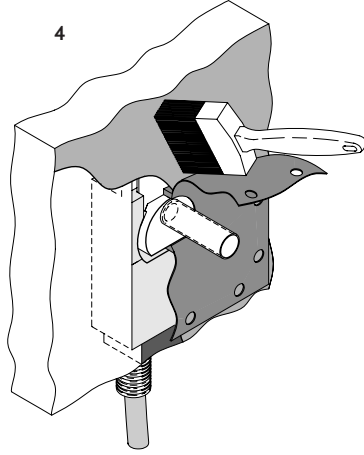

Raccordement 1/2" pour tubes en cuivre, tubes en plastique (tube PEX) ou tubes en acier

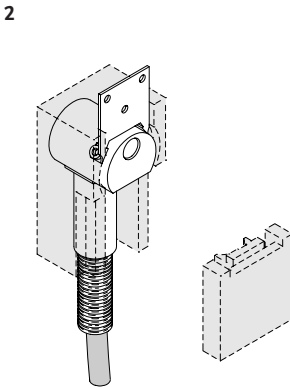

Enrobage - 2^{ème} fois sur membrane caoutchouc

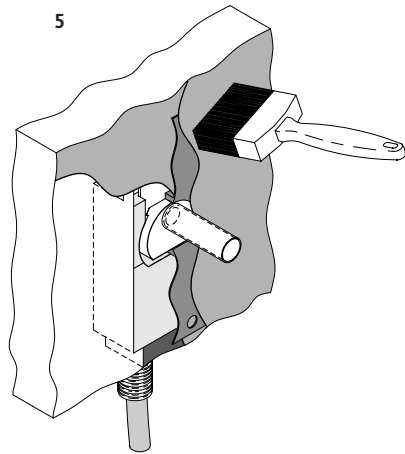

Scellement avec membrane

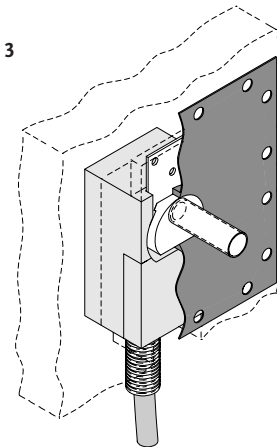

Revêtement mural, par ex. carrelage

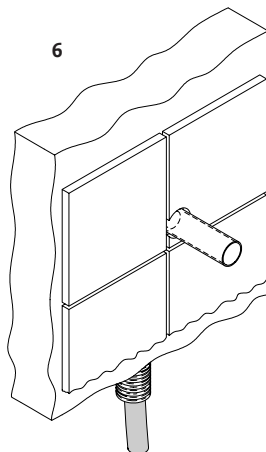

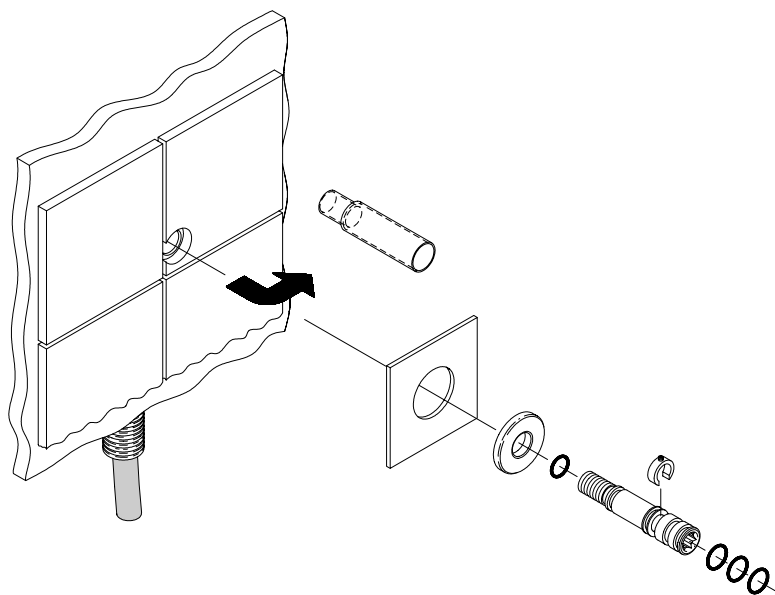
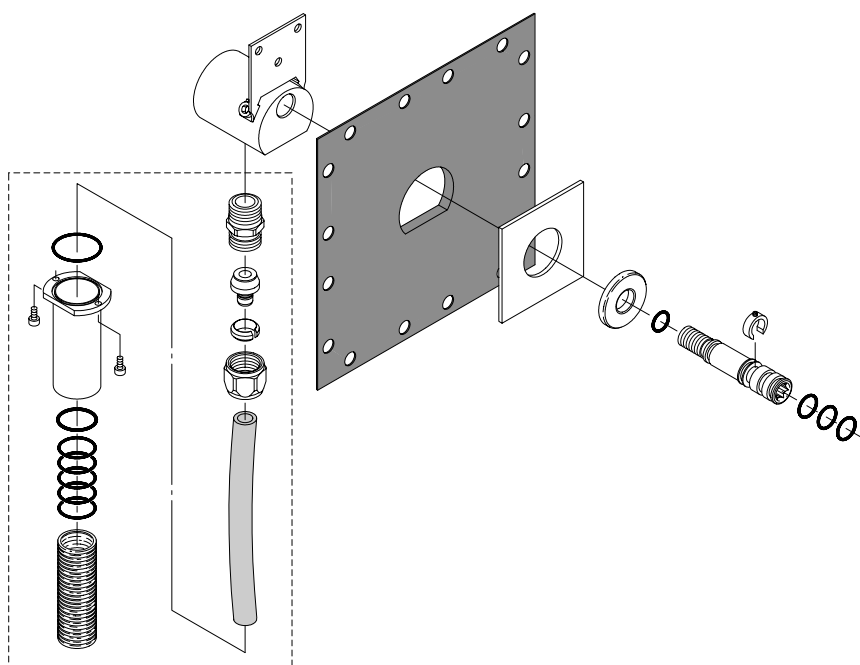
6. Assemblage final**7. Vue éclatée**

Accessoires non inclus !

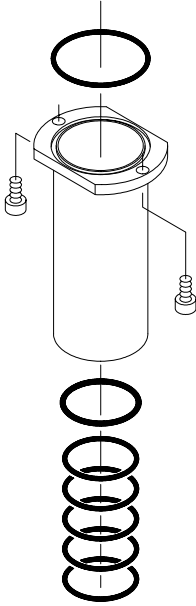

Accessoires pour tube ondulé

Nombre de jeux de chapeaux nécessaires		Réf. n°
		F1356
		F1357
1 x	F960747NU	F1372
		F1150
		F1358
		F1489

Le kit d'accessoires mentionné ci-dessus convient à tous les raccords d'un modèle donné.

Exemple : 1 x kit d'accessoires F960747NU destiné par exemple au modèle F1356 contient tous les raccords nécessaires.

1. Pulizia dei miscelatori

Tutti i miscelatori sono stati ispezionati e controllati uno a uno per verificarne la superficie e il funzionamento prima di lasciare gli stabilimenti dalla fabbrica.

Al fine di proteggere e mantenere la superficie in buone condizioni, osservare le istruzioni di seguito riportate:

Le superfici cromate

e quelle di ottone lucido devono essere pulite con un panno morbido e detersivi liquidi privi di acidi e sostanze abrasive, oppure con acqua saponata.

I residui calcarei

possono essere rimossi con comune aceto da cucina.

Le superfici smaltate colorate

perderanno lucentezza se pulite con sostanze abrasive. Usare soltanto acqua pulita o detersivi diluiti. Per eliminare i residui di calcare servirsi di comune aceto da cucina.

Aeratori

Calcare negli aeratori: immergere l'aeratore in aceto da cucina fino alla completa dissoluzione del calcare.

2. Dimensioni

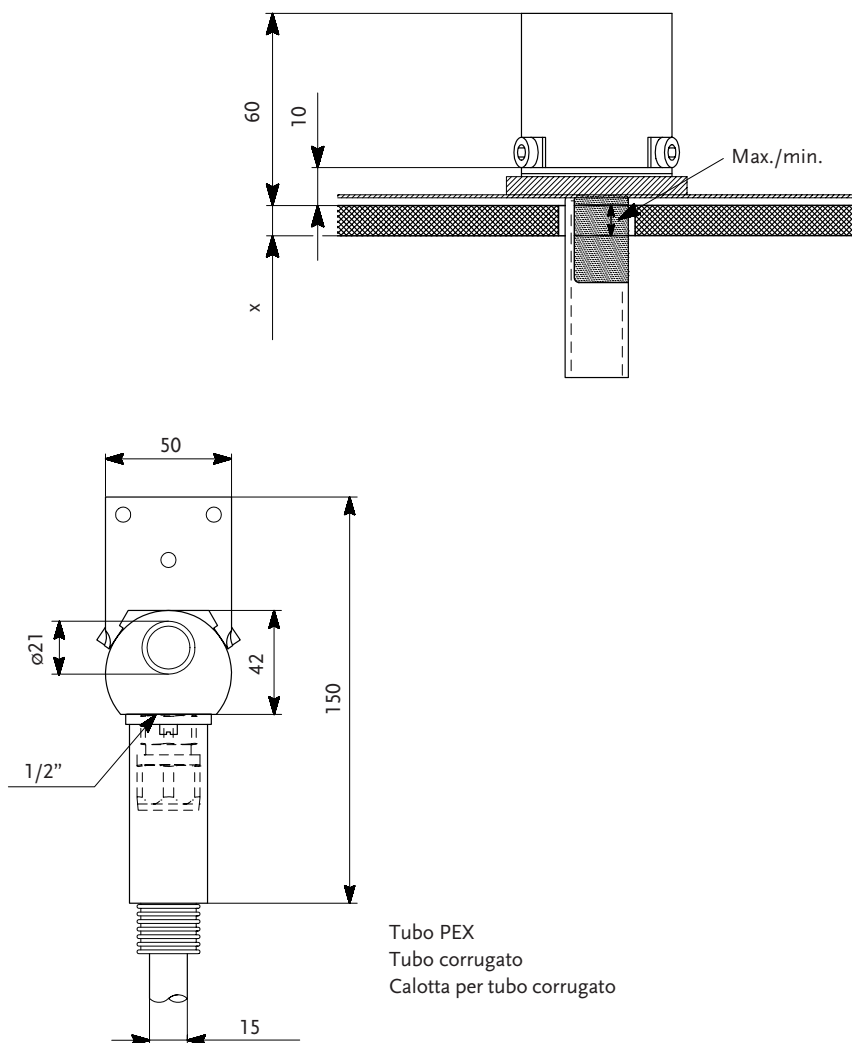

2. Dimensioni

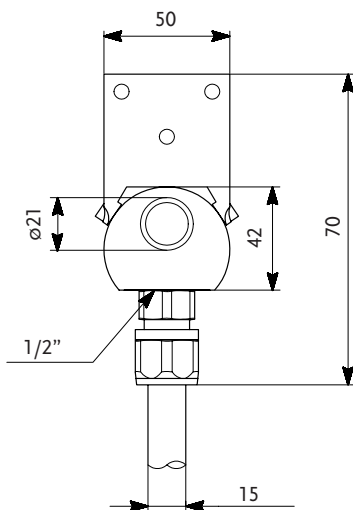
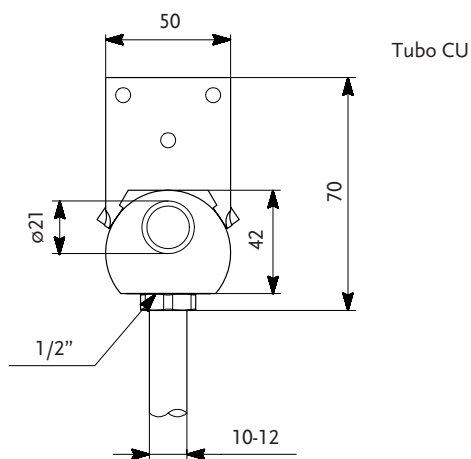

3. Kit di prolunga

Spessore standard del rivestimento parete = 3 - 13 mm.

In caso di rivestimento più spesso, è possibile prolungare l'asta (vedere tabella di seguito):

Spessore piastrelle (x)	Dimensioni dall'estremità dell'asta alla superficie esterne della parete (y)	Tipo di miscelatore					
		F1356 F1357 F1358 F1489	F1372 F1150				
3 - 13 mm	44 - 54 mm	Standard	Standard				
13 - 23 mm	34 - 44 mm	F960138NU	F960453NU				
23 - 33 mm	24 - 34 mm	F960139NU	F960743NU				
33 - 43 mm	14 - 24 mm	F960140NU	F960744NU				
43 - 53 mm	4 - 14 mm	F960141NU	F960745NU				

4. Indicazioni per il montaggio dei miscelatori interni in parete leggera (18 mm o 2 x 13 mm)

Sezione, parete leggera - 18 mm
Sezione, parete leggera - 2 x 13 mm

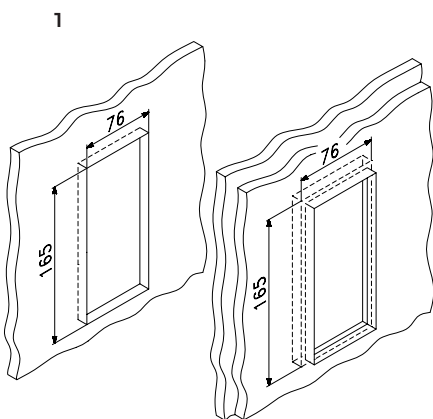

Rivestimento - La prima mano sotto la membrana di gomma

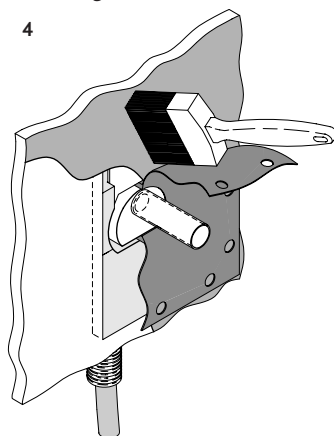

Raccordo 1/2" per condutture di rame, di plastica o d'acciaio e montaggio della scatola di stirene

Rivestimento - La seconda mano sopra la membrana di gomma

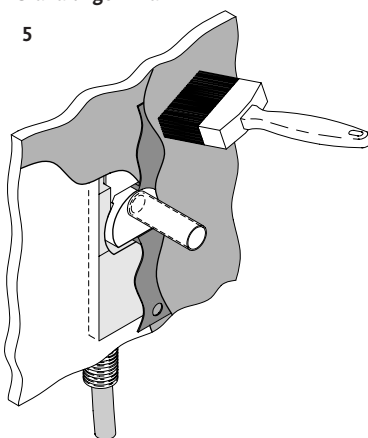
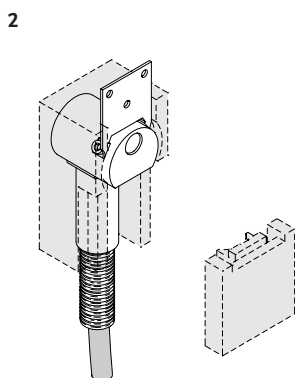

Muratura con membrana

Rivestimento parete, piastrellatura

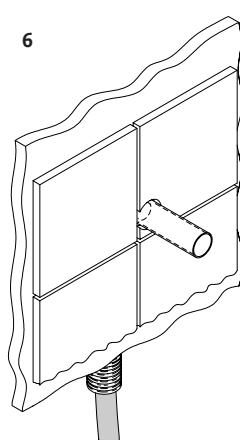
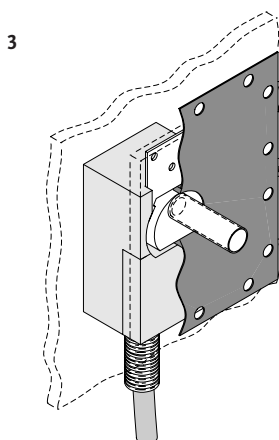

5. Indicazioni per il montaggio dei miscelatori interni in pareti di mattoni

Sezione, muratura in mattoni

1

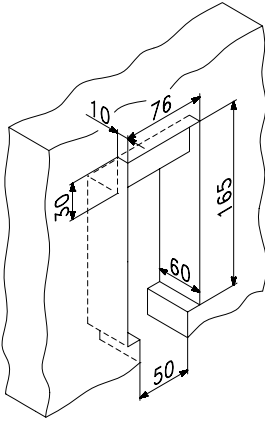

Rivestimento - La prima mano sotto la membrana di gomma

4

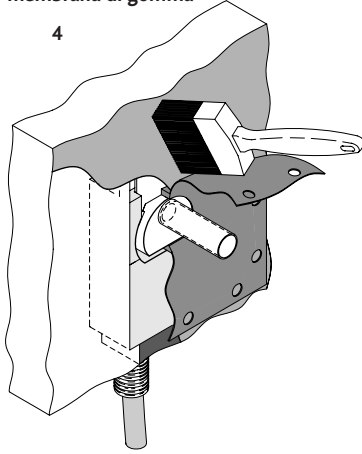

Raccordo 1/2" per tubi di rame, di plastica (tubo PEX) o di acciaio

2

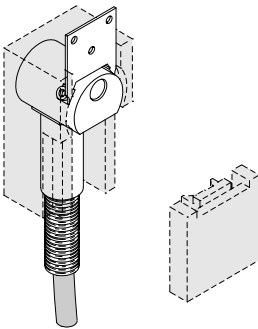

Rivestimento - La seconda mano sopra la membrana di gomma

5

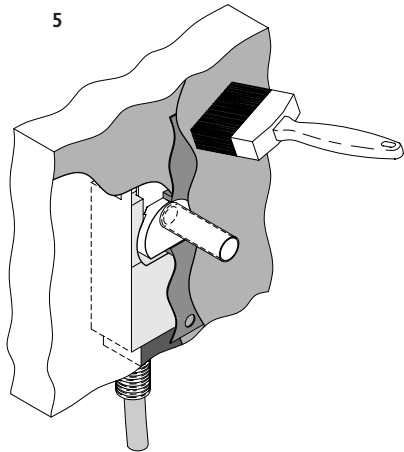

Muratura con membrana

3

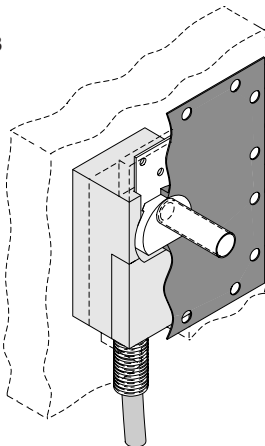

Rivestimento parete, piastrellatura

6

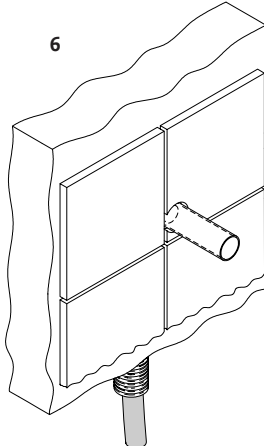

6. Montaggio finale

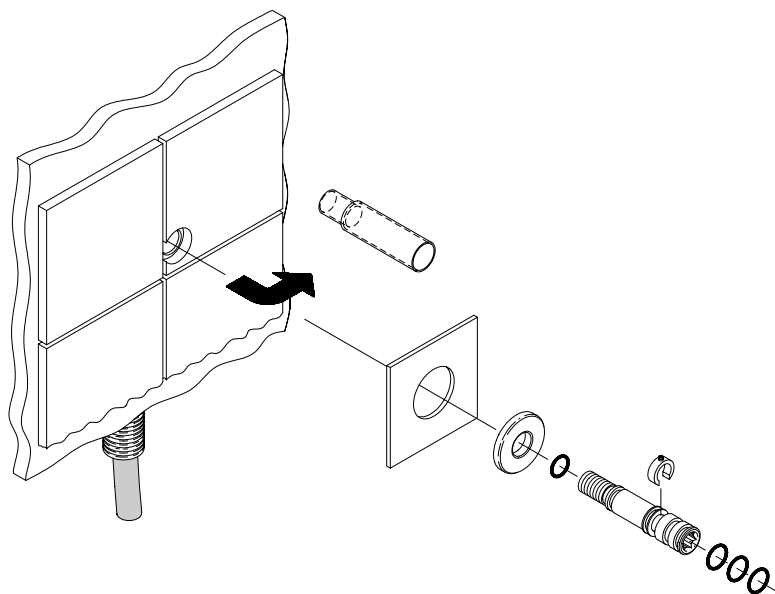

7. Esploso

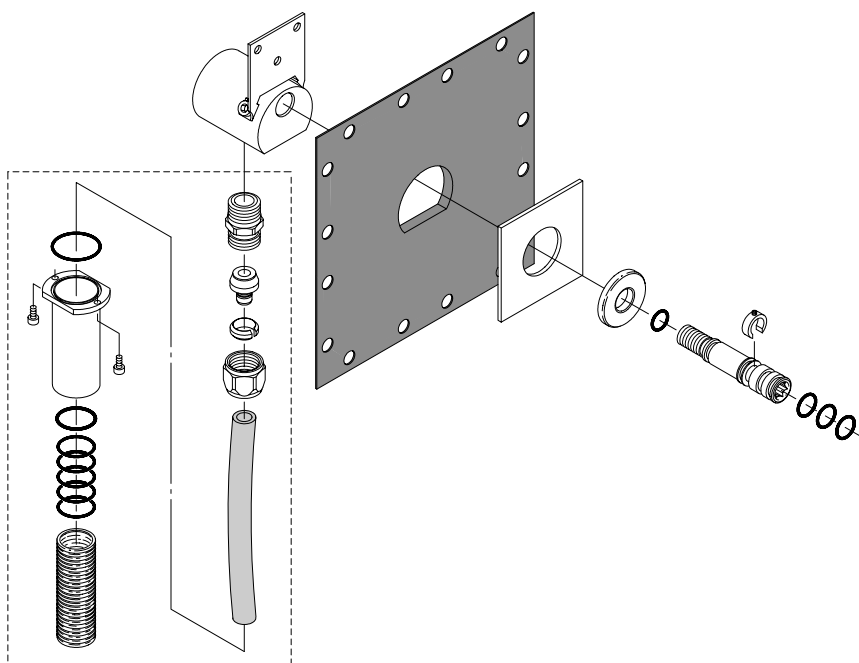

Accessori non inclusi!

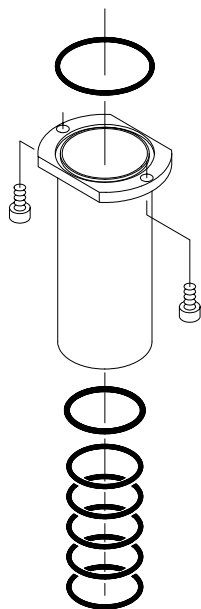

Accessori per tubo corrugato

N. di set calotte necessario		Articolo n.
1 x	F960747NU	F1356 F1357 F1372 F1150 F1358 F1489

Il kit di accessori sopra menzionato è idoneo per tutte le connessioni di un determinato modello.

Esempio: 1 x kit di accessori F960747NU per F1356 include tutte le connessioni necessarie.

1. Limpieza de los mezcladores

La superficie y la función de cada mezclador han sido inspeccionadas y comprobadas una por una, antes de salir de fábrica.

Para proteger y conservar la superficie, siga las instrucciones siguientes:

Superficies cromadas

al igual que las superficies doradas, de bronce pulido, deben limpiarse con un paño suave y productos de limpieza no ácidos ni abrasivos, o con agua jabonosa.

Residuos de cal

pueden eliminarse con vinagre común de uso doméstico.

Superficies esmaltadas de color

perderán su aspecto brillante si se limpian con productos que contengan abrasivos. Use únicamente agua limpia o un detergente diluido. Los residuos de cal pueden eliminarse con vinagre común de uso doméstico.

Aireadores

Cal en los aireadores: Sumerja el aireador en vinagre de uso doméstico y déjelo en remojo hasta que se disuelva la cal.

2. Dimensiones

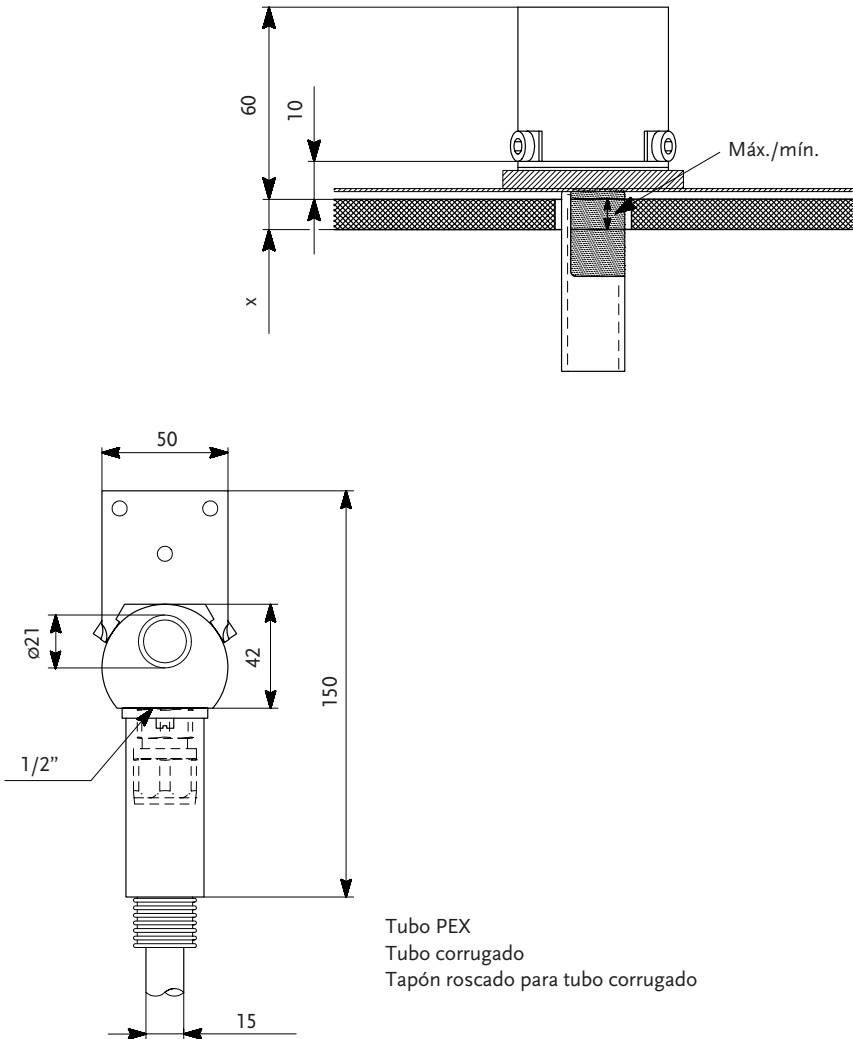

2. Dimensiones

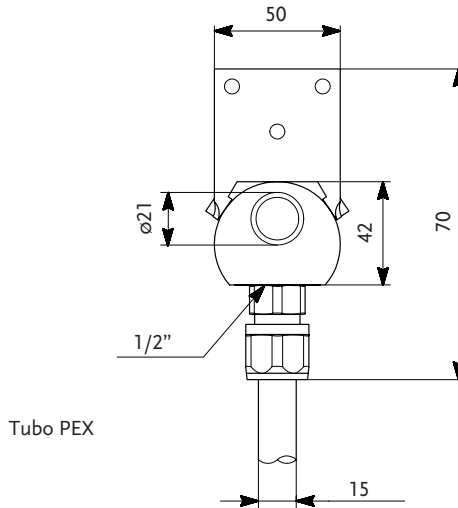
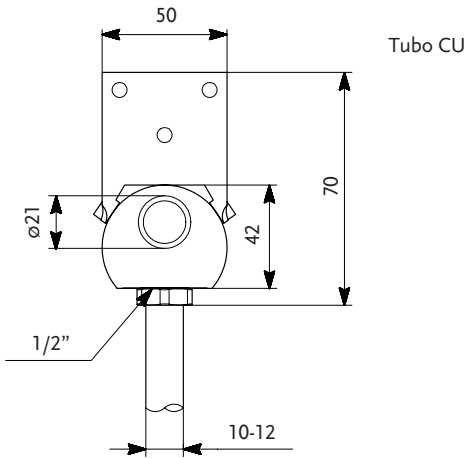

3. Kits de prolongación

Grosor estándar para revestimiento de muros = 3 - 13 mm.

En caso de un revestimiento de muros más grueso, se puede prolongar el huso (consulte la siguiente tabla):

Grosor del azulejo (x)	Medida desde el extremo del eje hasta la superficie exterior de la pared (y)	Tipo de mezclador					
		F1356	F1357	F1358	F1372	F1489	F1150
3 - 13 mm	44 - 54 mm	Estándar	Estándar				
13 - 23 mm	34 - 44 mm	F960138NU	F960453NU				
23 - 33 mm	24 - 34 mm	F960139NU	F960743NU				
33 - 43 mm	14 - 24 mm	F960140NU	F960744NU				
43 - 53 mm	4 - 14 mm	F960141NU	F960745NU				

4. Directrices para el montaje de mezcladores empotrados en paredes delgadas (18 mm o 2 x 13 mm)

Desgastado, pared delgada - 18 mm
Desgastado, pared delgada - 2 x 13 mm

1

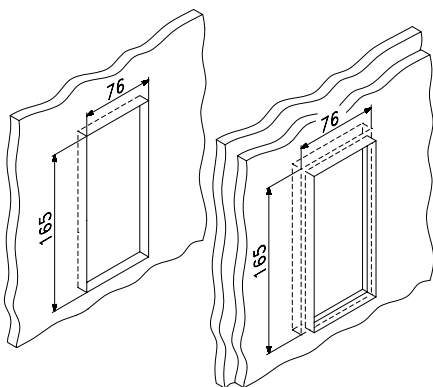

1/2" conexión para tubos de cobre, tubos de plástico, o tubos de acero y montaje de caja de estireno

2

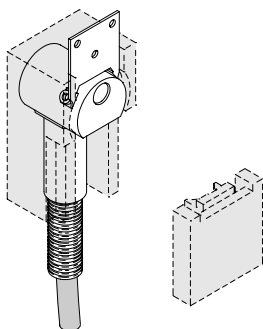

Recubrimiento con membrana

3

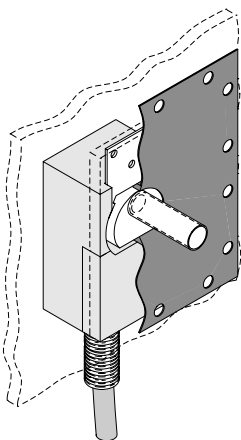

Revestimiento - 1ª vez bajo la membrana de caucho

4

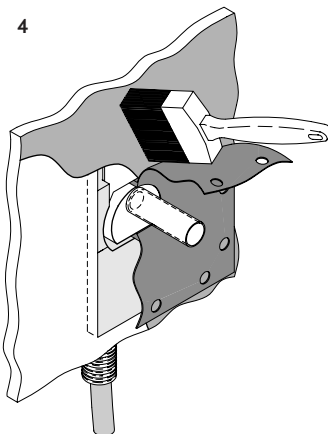

Revestimiento - 2ª vez sobre la membrana de caucho

5

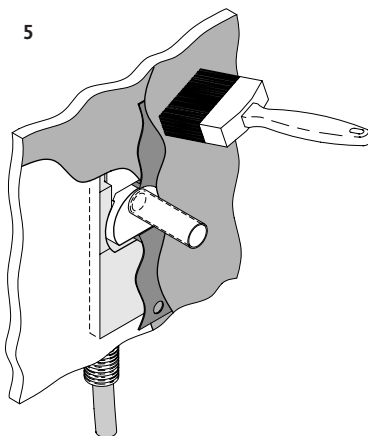

Revestimiento, p.ej., azulejos

6

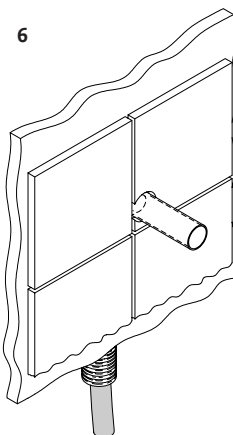

5. Directrices para el montaje de mezcladores empotrados en paredes de ladrillo

Desgastada, obra de ladrillo

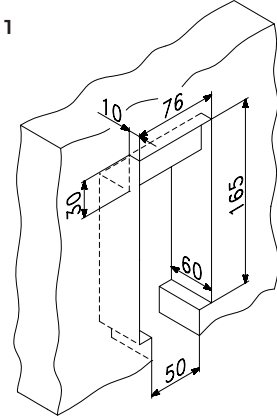

Revestimiento - 1ª vez bajo la membrana de caucho

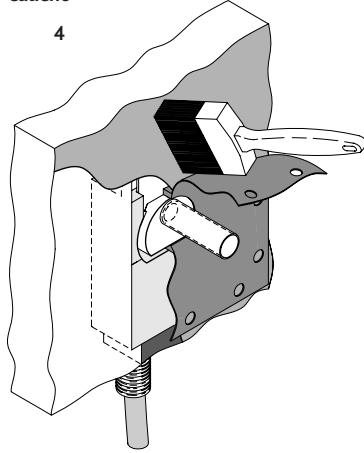

1/2" conexión para tubos de cobre, tubos de plástico (tubo PEX), o tubos de acero

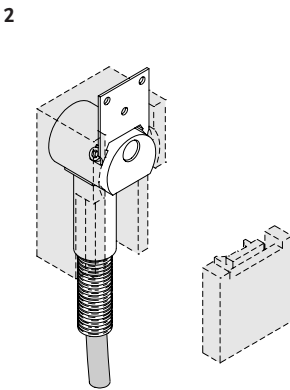

Revestimiento - 2ª vez sobre la membrana de caucho

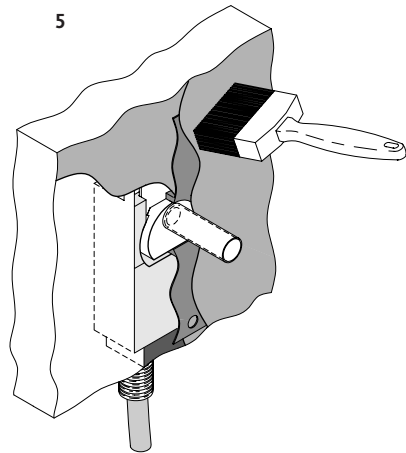

Recubrimiento con membrana

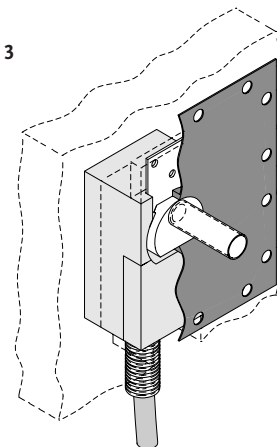

Revestimiento, p.ej., azulejos

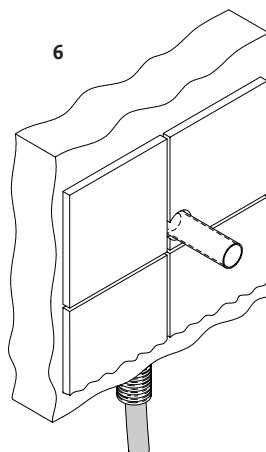

6. Montaje final

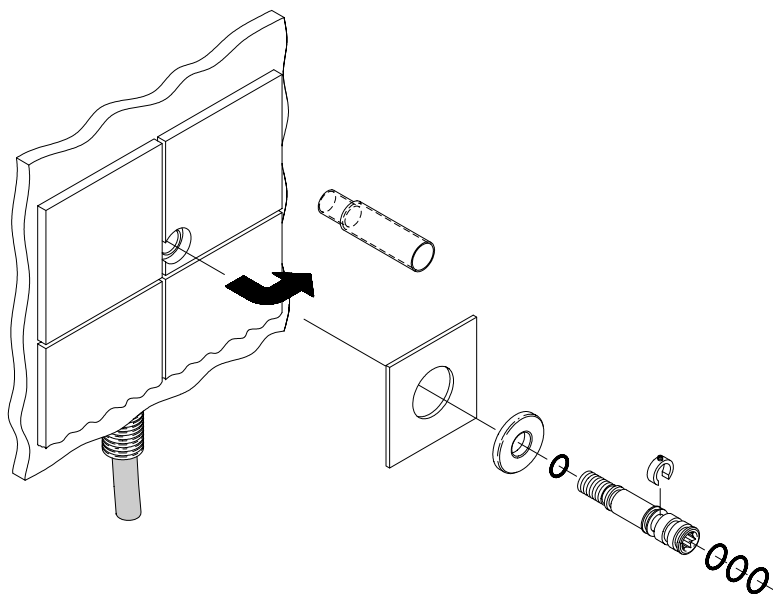

7. Vista detallada

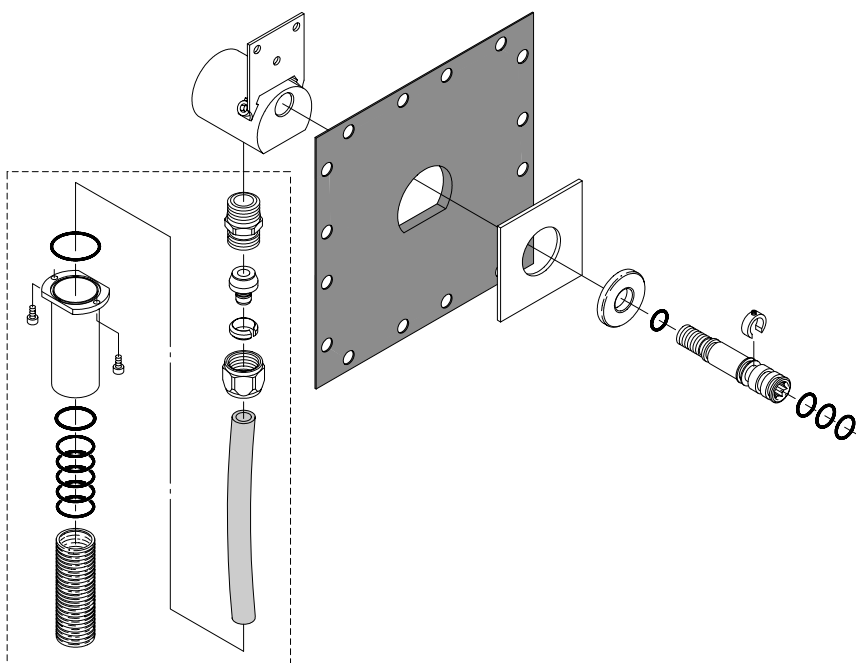

¡Accesorios no incluidos!

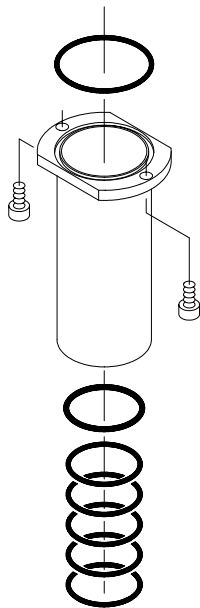

Accesorios para tubo corrugado

N° de juegos de tapones roscados necesarios		Artículo n°
		F1356
		F1357
1 x	F960747NU	F1372
		F1150
		F1358
		F1489

El kit de accesorios arriba mencionado es apropiado para todas las conexiones de un modelo determinado.

Ejemplo: 1 x kit de accesorios F960747NU, p.ej., para F1356 incluye todas las conexiones necesarias.

1. Limpeza das misturadoras

A superfície e o funcionamento de cada misturadora foram inspeccionados, tendo as misturadoras sido verificadas uma a uma antes de saírem da fábrica.

Para proteger e conservar a superfície, siga as instruções abaixo:

Superfícies cromadas

As superfícies cromadas bem como as superfícies de latão polidas devem ser limpas com um pano macio e materiais de limpeza líquidos, não ácidos e sem abrasivos ou com água com sabão.

Resíduos de calcário

Os resíduos de calcário podem ser retirados com o vulgar vinagre caseiro.

Superfícies esmaltadas coloridas

Estas superfícies perderão o seu aspecto brilhante se forem limpas com materiais contendo abrasivos. Utilize apenas água limpa ou detergente diluído. Os resíduos de calcário podem ser retirados com o vulgar vinagre caseiro.

Arejadores

Calcário nos arejadores: mergulhe o arejador em vinagre caseiro até o calcário dissolver.

2. Dimensões

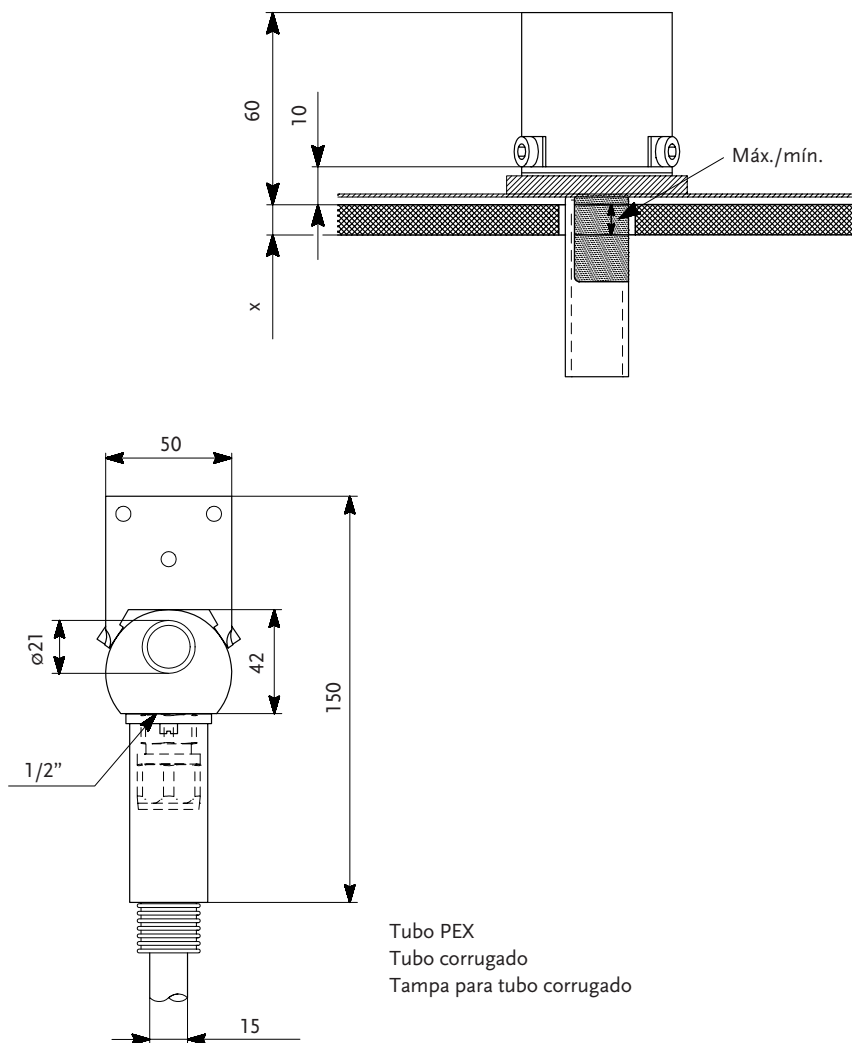

2. Dimensões

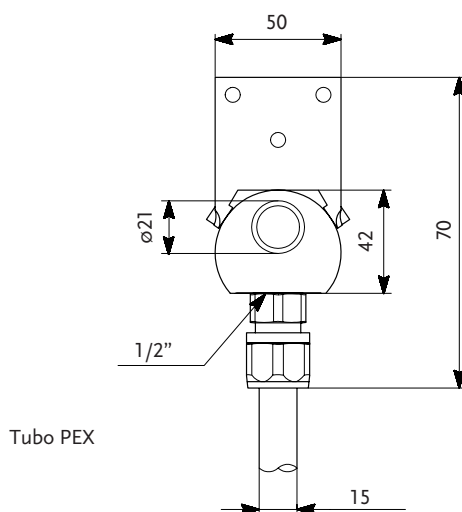
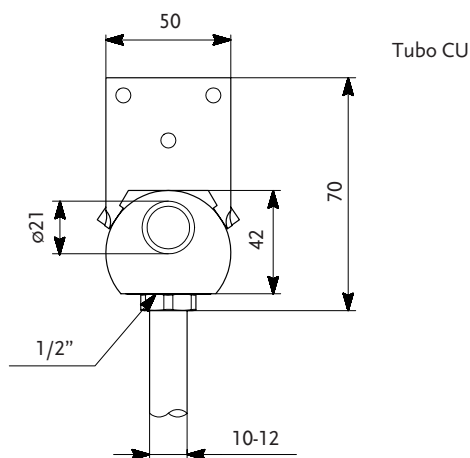

3. Kits de extensão

Espessura standard do revestimento de parede = 3 - 13 mm.

No caso de um revestimento de parede mais grosso, o fuso pode ser prolongado (ver tabela a seguir):

Espessura do azulejo (x)	Dimensão da extremidade do fuso à superfície exterior da parede (y)	Tipo de misturadora					
		F1356	F1357	F1358	F1372	F1489	F1150
3 - 13 mm	44 - 54 mm	Standard	Standard				
13 - 23 mm	34 - 44 mm	F960138NU	F960453NU				
23 - 33 mm	24 - 34 mm	F960139NU	F960743NU				
33 - 43 mm	14 - 24 mm	F960140NU	F960744NU				
43 - 53 mm	4 - 14 mm	F960141NU	F960745NU				

4. Instruções para montagem de misturadoras ocultas em paredes finas (18 mm ou 2 x 13 mm)

Recorte, parede fina - 18 mm
 Recorte, parede fina - 2 x 13 mm

1

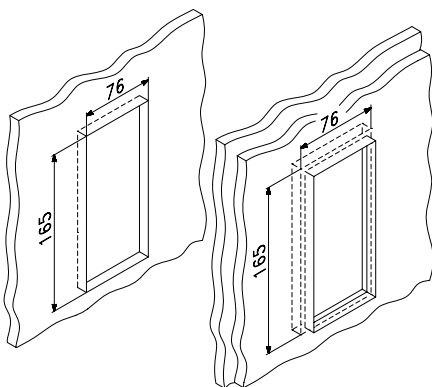

Camada - 1ª vez sob membrana de borracha

4

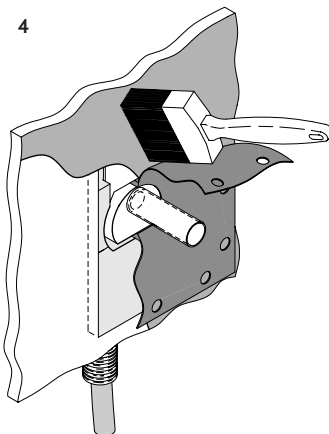

Ligação de 1/2" para tubos de cobre, tubos de plástico ou tubos de aço e montagem de caixa de estireno

Camada - 2ª vez sobre membrana de borracha

2

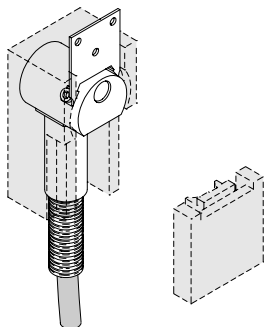

5

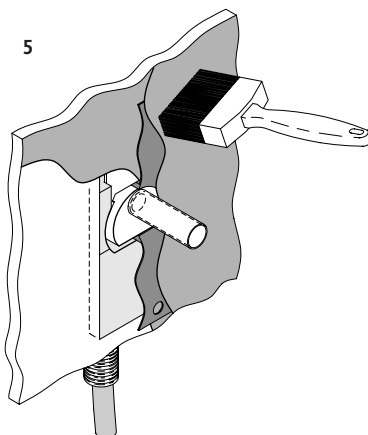

Tapar com membrana

Revestimento de parede, por exemplo, azulejos

3

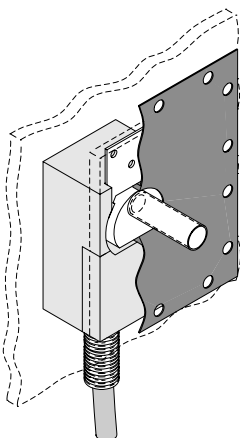

6

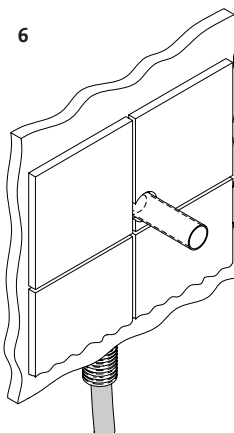

5. Instruções para montagem de misturadoras ocultas em paredes de tijolo

Recorte, construção de tijolo

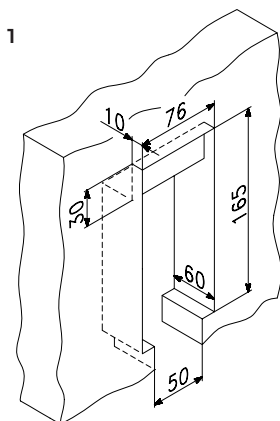

Camada - 1ª vez sob membrana de borracha

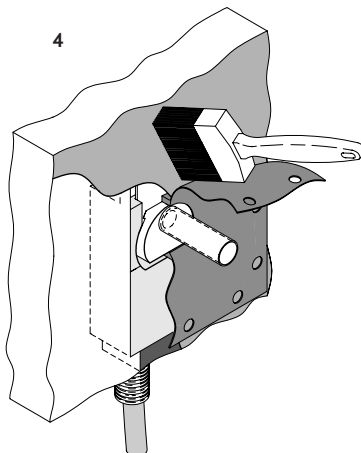

Ligação de 1/2" para tubos de cobre, tubos de plástico (tubo PEX) ou tubos de aço

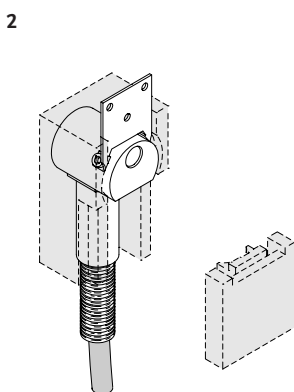

Camada - 2ª vez sobre membrana de borracha

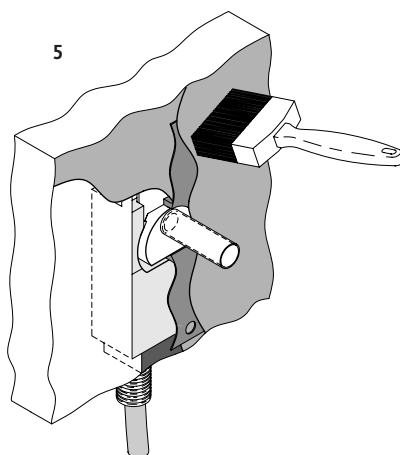

Tapar com membrana

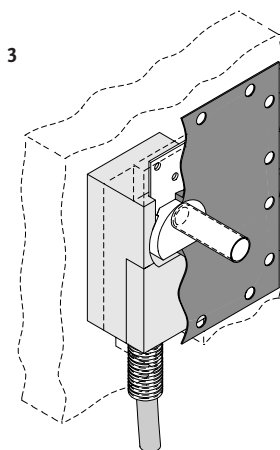

Revestimento de parede, por exemplo, azulejos

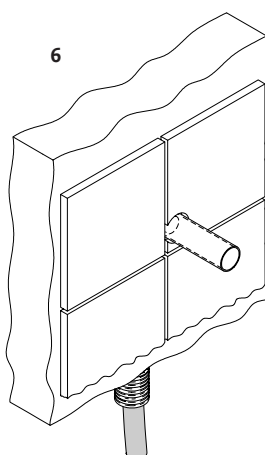

6. Montagem final

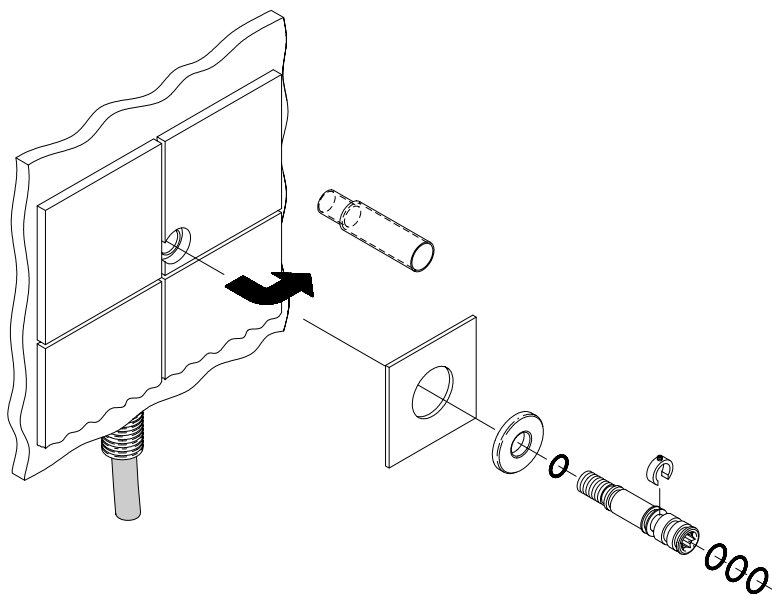

7. Vista em destaque dos componentes

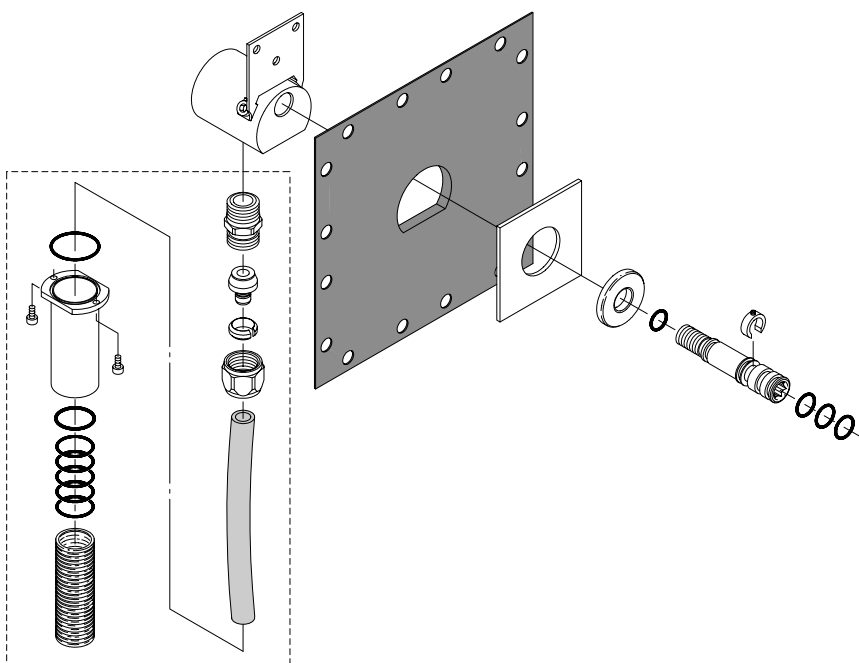

Acessórios não incluídos!

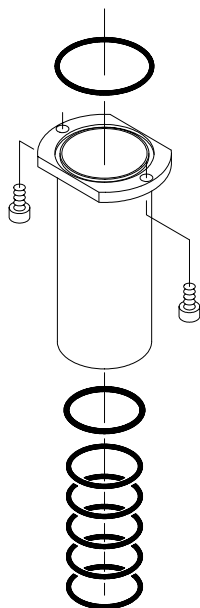

Acessório para tubo corrugado

N.º de conjuntos de tampas necessários		Artigo n.º
		F1356
		F1357
1 x	F960747NU	F1372
		F1150
		F1489

O kit de acessórios acima mencionado é adequado para todas as ligações de um determinado modelo. Exemplo: 1 x kit de acessórios F960747NU, por exemplo, F1356 inclui todas as ligações necessárias.

1. Mengkranen reinigen

Voordat ze de fabriek verlaten worden alle kranen stuk voor stuk gecontroleerd op hun goede werking en de afwezigheid van beschadigingen. Zo houdt u het oppervlak van de kraan in goede conditie:

Chromen oppervlakken

en gepolijste koperen oppervlakken reinigt u met een zachte doek en zeepsop of een vloeibaar, zuurvrij reinigingsproduct zonder schuurmiddel.

Kalkresten

verwijdert u met gewone huishoudazijn.

Gekleurde emailoppervlakken

verliezen hun glans als ze worden gereinigd met producten die schuurmiddelen bevatten. Gebruik alleen schoon water of verdunde reinigingsmiddelen. Kalkresten verwijdert u met gewone huishoudazijn.

Beluchters

Kalk in beluchters: Week de beluchter in huishoudazijn totdat de kalk is opgelost.

2. Afmetingen

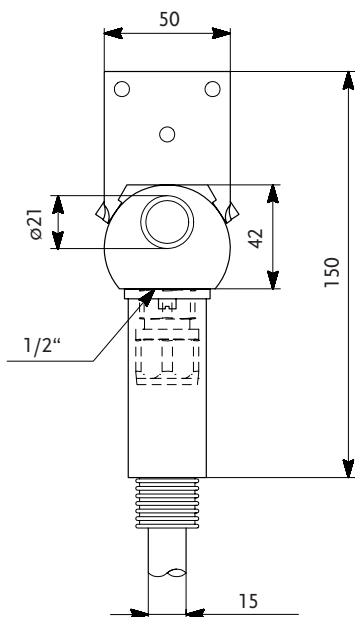
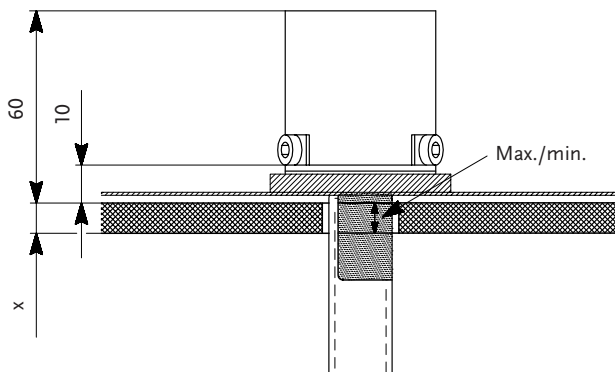

PEX-buis
Ribbelbuis
Dop voor ribbelbuis

2. Afmetingen

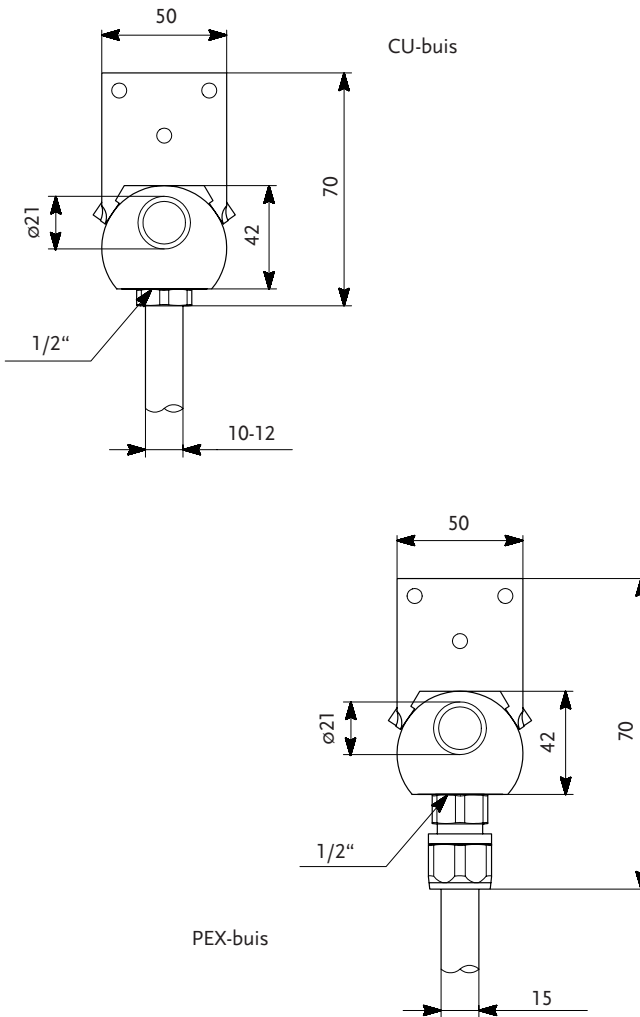

3. Verlengsets

Standaarddikte wandbekleding = 3 - 13 mm.

Voor dickere wandbekledingen kan de spil worden verlengd (zie onderstaande tabel):

Tegeldikte (x)	Afmeting van spileind tot buitenoppervlak wand (y)	Type mengkraan					
		F1356 F1357 F1358 F1489	F1372 F1150				
3 - 13 mm	44 - 54 mm	Standaard	Standaard				
13 - 23 mm	34 - 44 mm	F960138NU	F960453NU				
23 - 33 mm	24 - 34 mm	F960139NU	F960743NU				
33 - 43 mm	14 - 24 mm	F960140NU	F960744NU				
43 - 53 mm	4 - 14 mm	F960141NU	F960745NU				

4. Richtlijnen voor montage van inbouwmengkranen in lichtgewicht wanden (18 mm of 2 x 13 mm)

Uitsparing, lichtgewicht wand - 18 mm
 Uitsparing, lichtgewicht wand - 2 x 13 mm

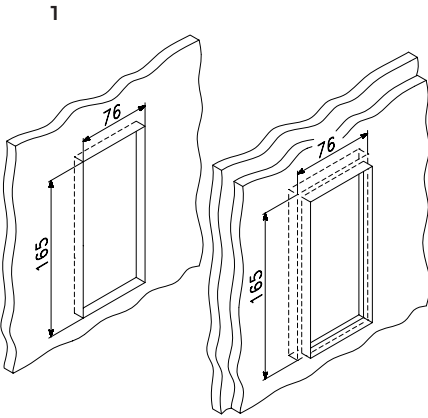

Coating - 1^e maal onder rubber membraan

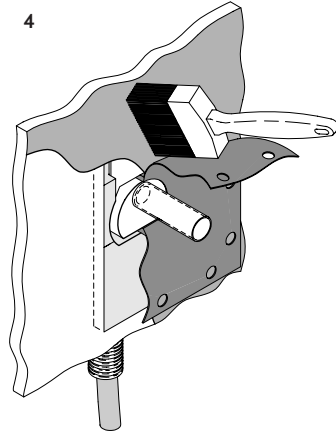

1/2" aansluiting voor koperen, plastic of stalen leidingen en montage van styreendoos

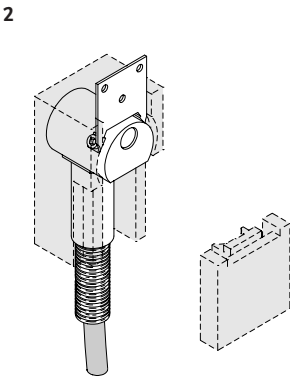

Coating - 2^e maal over rubber membraan heen

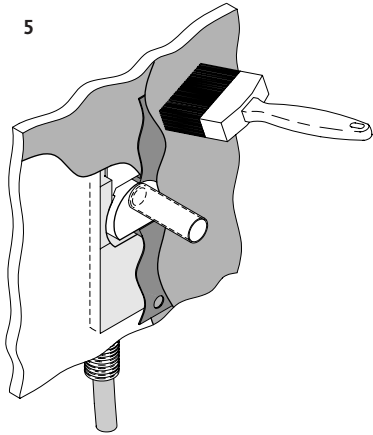

Dichtmaken met membraan

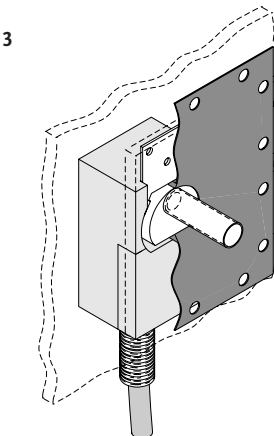

Wandbekleding, bijv. tegelwerk

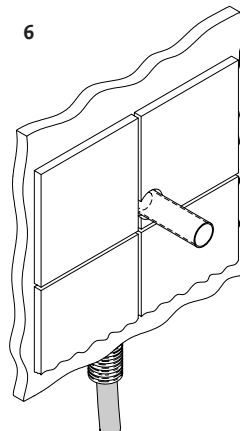

5. Richtlijnen voor montage van inbouwmengkranen in gemetselde muren

Uitsparing, metselwerk

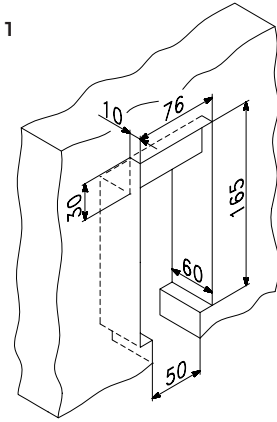

Coating - 1^e maal onder rubber membraan

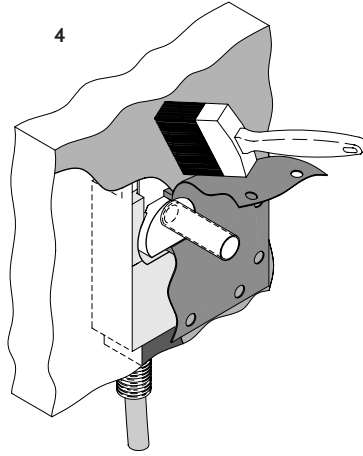

1/2" aansluiting voor koperen, plastic (PEX) of stalen leidingen

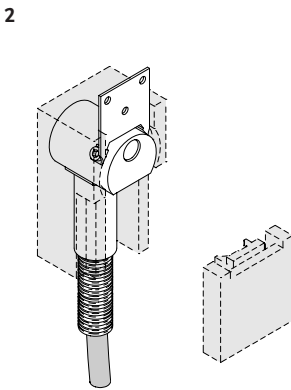

Coating - 2^e maal over rubber membraan heen

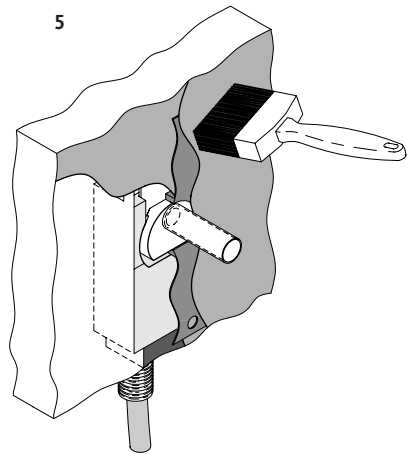

Dichtmaken met membraan

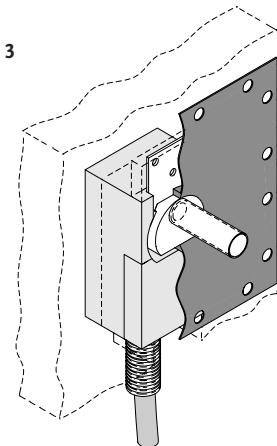

Wandbekleding, bijv. tegelwerk

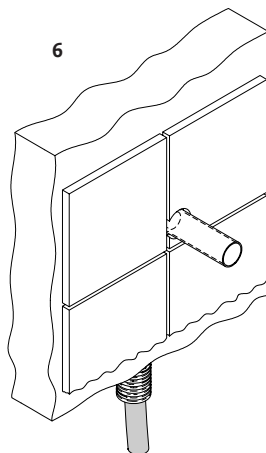

6. Eindmontage

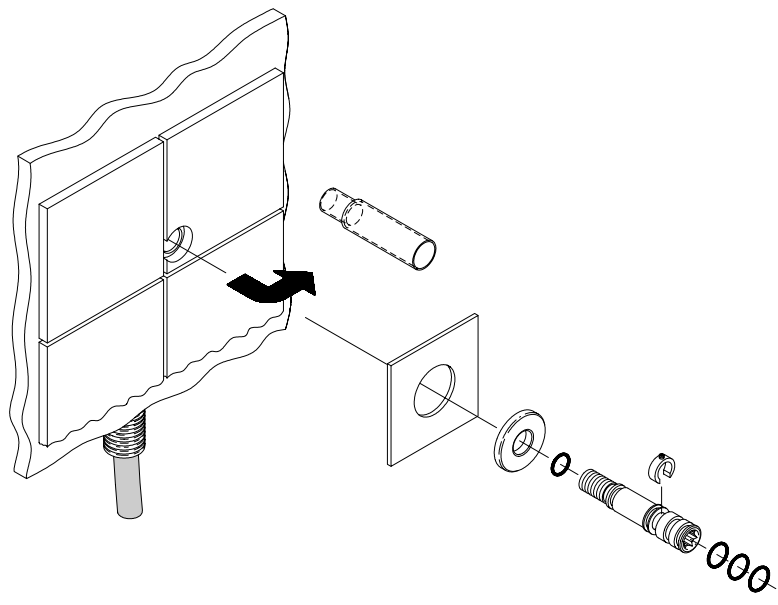

7. Opengewerkte tekening

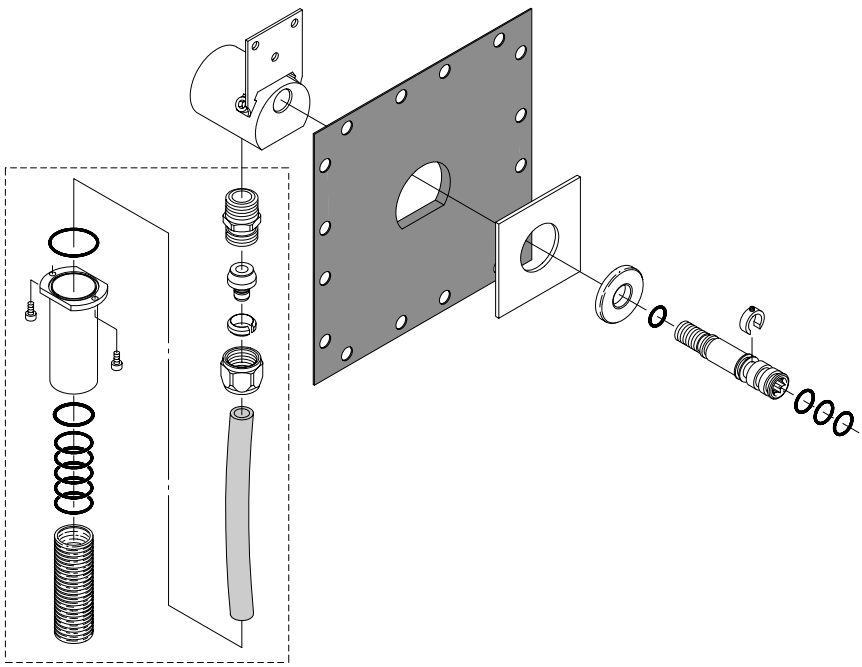

Accessoires niet meegeleverd!

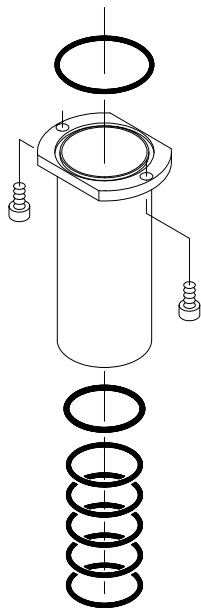

Accessoireset voor ribbelbuis

Aantal benodigde dopsets		Artikelnr.
		F1356
		F1357
1 x	F960747NU	F1372
		F1150
		F1358
		F1489

Bovenstaande accessoireset is geschikt voor alle aansluitingen van een gegeven model.
 Voorbeeld: 1 x accessoireset F960747NU voor bijv. F1356 bevat alle benodigde verbindingen.







United Kingdom

Ideal Standard National Avenue Hull England HU5 4HS
TEL.: 01482 499685

Germany

pro-Service Euskirchener Straße 80 D-63322 Rödemark
Tel.: +49 (0) 228-521580 Fax: +49 (0) 228-521589
www.pro-service.info E-mail: pro-service.info@aseur.com

France

Ideal Standard France Bat.H, 165 Av. du Bois de la pie, Paris N2
95920 Roissy CDG Tel.: +43 0149 388 181 www.idealstandard.fr

Scandinavian

Ideal Standard Scandinavia A/S Tulipvej 1 DK-7100 Vejle
Tel.: +45 75 84 10 10 Fax: +45 75 84 10 24 www.borma.dk

Nederland

Ideal Standard Nederland L.J.Costerstraat 30 Postbus 7 5900 AA Venlo
Tel.: +31 77 355 08 07

Italiano

Ideal Standard Divisione di American Standard italia S.r.l.
Via Domodosola, 19 20145 Milano Tel.: +39 800 652290

Espaniól

Ideal Standard, S.L. Sant marti, s/n
08107 Martorelles (Barcelona) Tel. General +34 93 5 44 01 60

Portogal

Ideal Standard Portogal Nogueira - Ap. 4 4711 - 909 Braga
08107 Martorelles (Barcelona) Tel.: +253 240001 e-mail: silvaj@aseur.com