



Concealed Mixers - F1344 - F1152 - F1629 - F1155 - Guidelines	Page 2
Indbygningsarmatur - F1344 - F1152 - F1629 - F1155 - Vejledning	Side 8
Verdeckte Mischer - F1344 - F1152 - F1629 - F1155 - Installationshinweise ..	Seite 14
Mitigeurs encastrés - F1344 - F1152 - F1629 - F1155 - Instructions	Page 20
Miscelatori interni - F1344 - F1152 - F1629 - F1155 - Indicazioni	Pag. 26
Mezcladores empotrados - F1344 - F1152 - F1629 - F1155 - Directrices ..	Página 32
Misturadoras ocultas - F1344 - F1152 - F1629 - F1155 - Instruções	Página 38
Inbouwmengkranen - F1344 - F1152 - F1629 - F1155 - Richtlijnen	Pagina 44

1. Cleaning of mixers

The surface and function of each mixer have been inspected and checked one by one, before they leave the Factory.
To protect and preserve the surface, please follow below instructions:

Chrome surfaces

as well as polished brass surfaces should be cleaned with a soft cloth and liquid, acid-free cleaning materials without abrasive, or with soap water.

Lime residues

can be removed with common household vinegar.

Coloured enamel surfaces

will loose their shiny look if cleaned with materials containing abrasive. Use only clean water or diluted detergent. Lime residues can be removed with common household vinegar.

Aerators

Lime in aerators: Put the aerator in household vinegar and let it soak, until the lime dissolves.

2. Dimensions

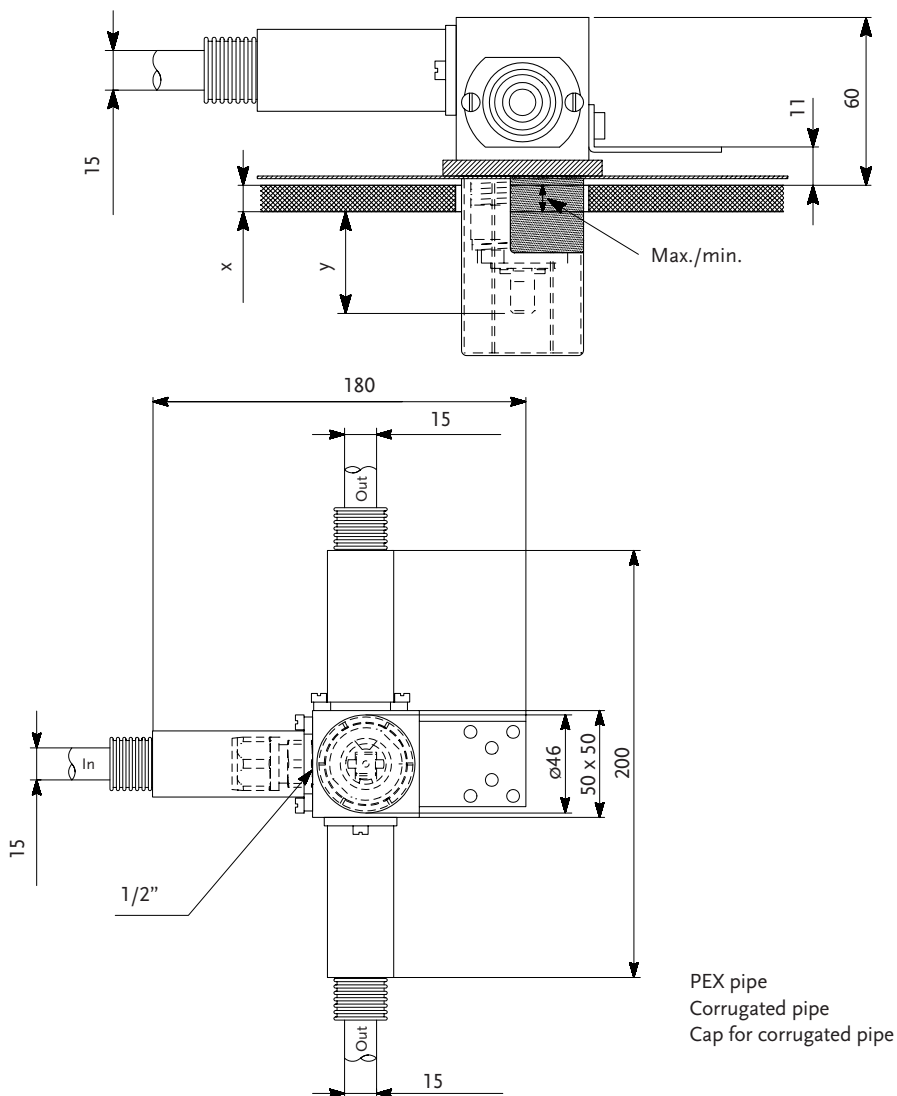

2. Dimensions

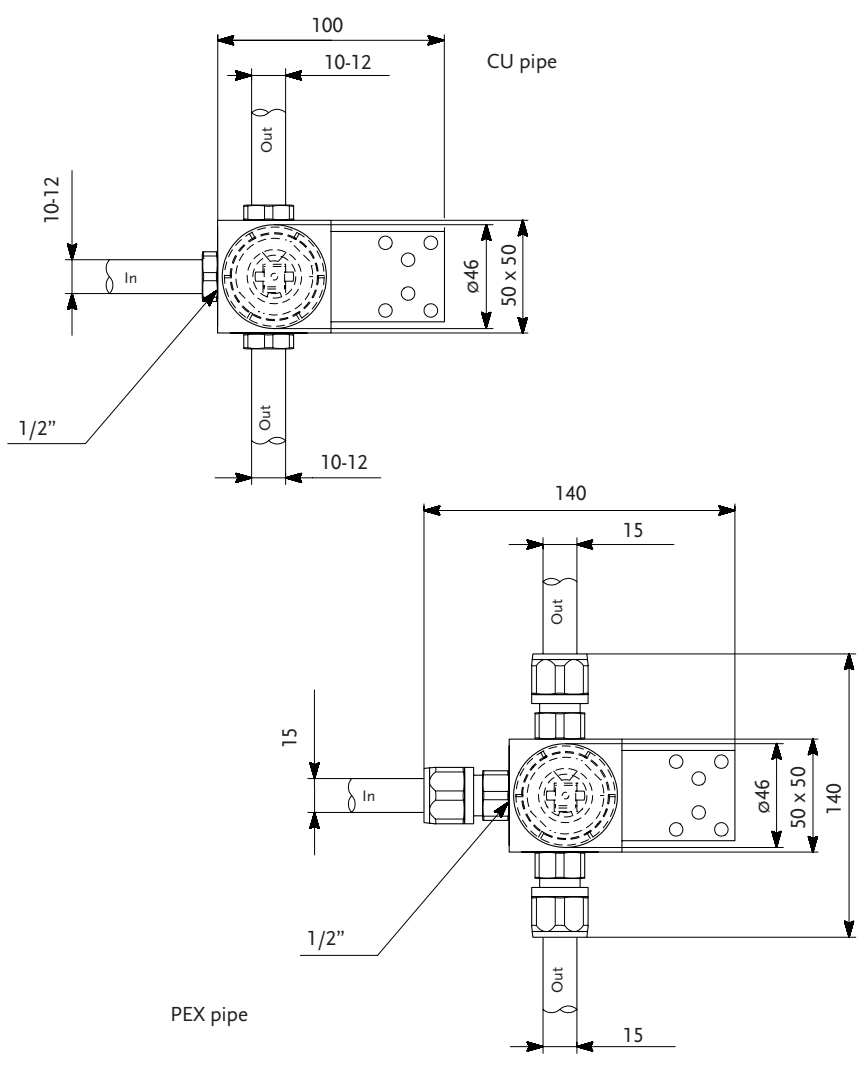

3. Extension kits

Standard thickness of wall covering = 3 – 13 mm.
 In case of a thicker wall covering extension kit's can be supplied (see below table):

Tile thickness (x)	Dimension from spindle end to outside sur- face of wall (y)	Mixer type	
		F1344 F1152 F1629 F1155	
3 - 13 mm	44 - 54 mm	Standard	
13 - 23 mm	34 - 44 mm	F960122NU	
23 - 33 mm	24 - 34 mm	F960123NU	
33 - 43 mm	14 - 24 mm	F960124NU	
43 - 53 mm	4 - 14 mm	F960125NU	

4. Guidelines for mounting of concealed mixers in lightweight wall (18 mm or 2 x 13 mm)

Cut-out, lightweight wall - 18 mm
 Cut-out, lightweight wall - 2 x 13 mm

Coating - 1st time under rubber membrane

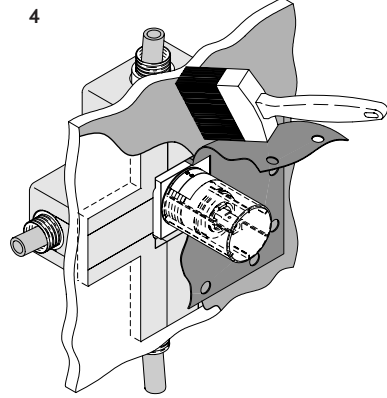
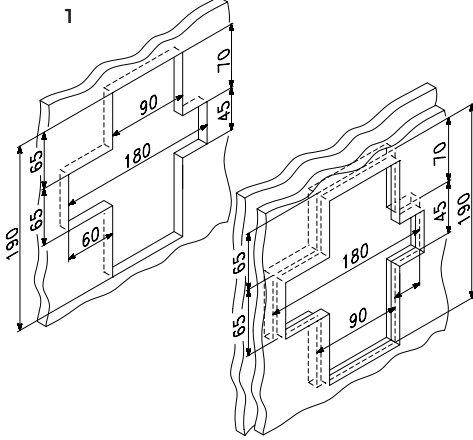

1/2" connection for copper tubes, plastic tubes, or steel tubes and assembly of styrenbox

Coating - 2nd time over rubber membrane

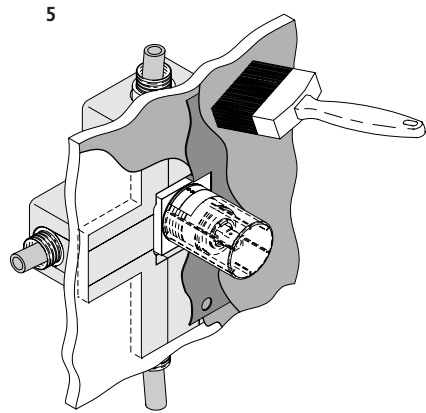
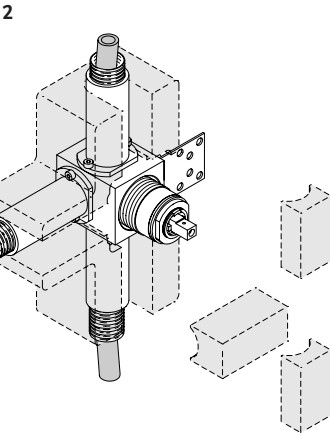

Walling up with membrane

Wall covering, e.g. tiling

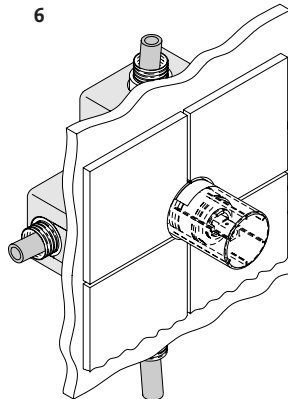
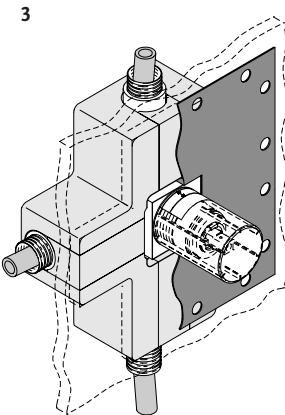

5. Guidelines for mounting of concealed mixers in brick wall

Cut-out, brickwork

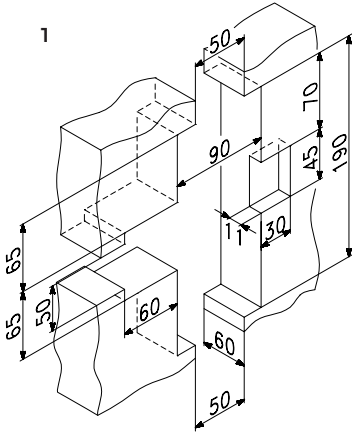

Coating - 1st time under rubber membrane

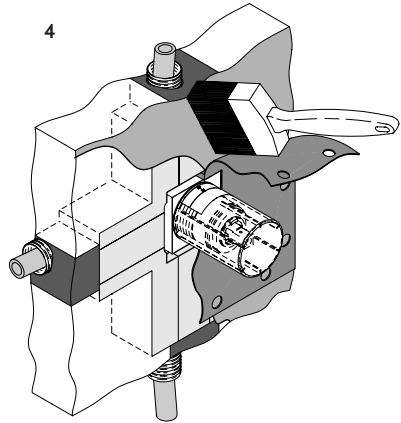

1/2" connection for copper tubes, plastic tubes (PEX pipe), or steel tubes

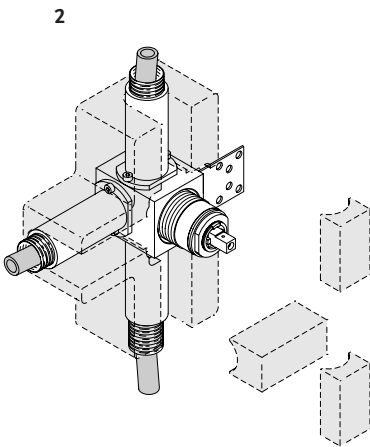

Coating - 2nd time over rubber membrane

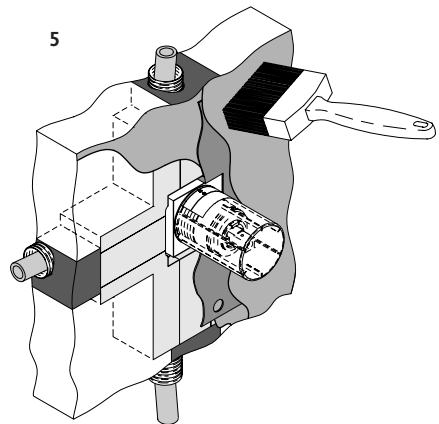

Walling up

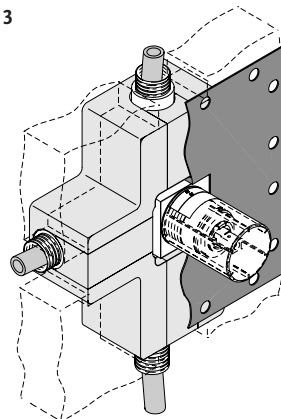

Wall covering, e.g. tiling

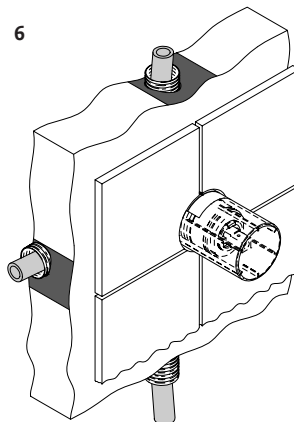

6. Final assembly

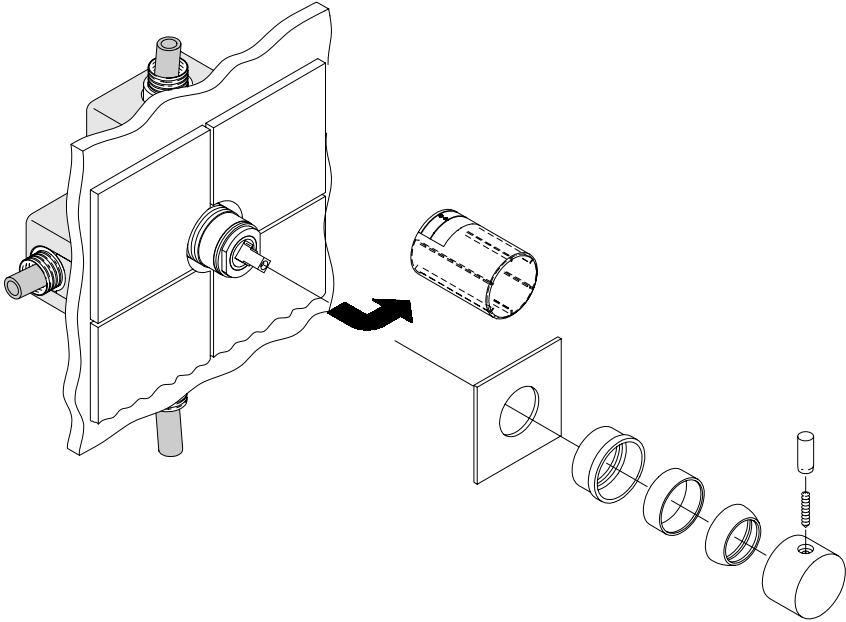

7. Exploded view

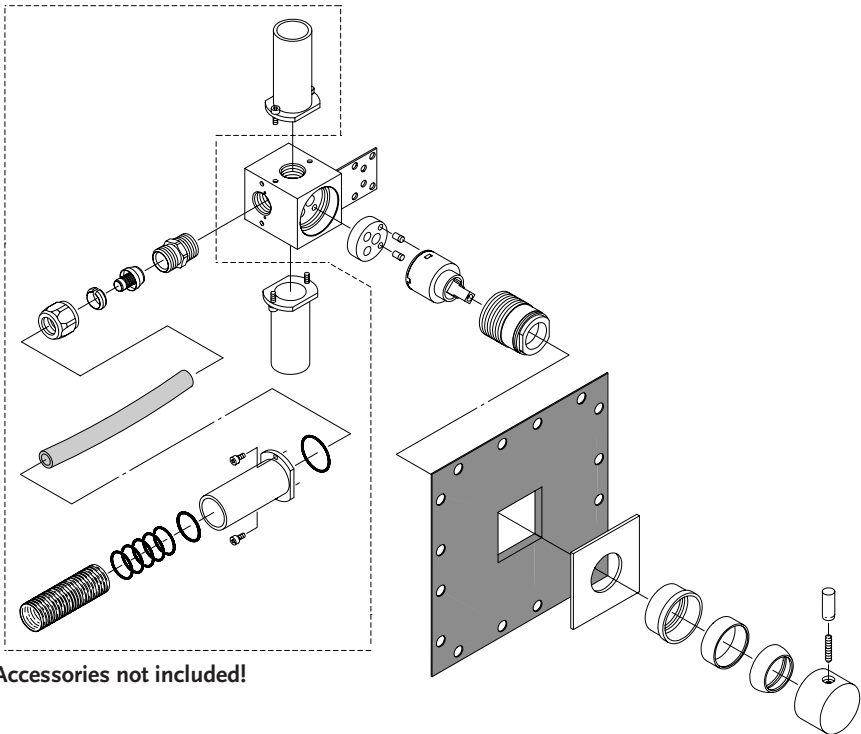

Accessories not included!

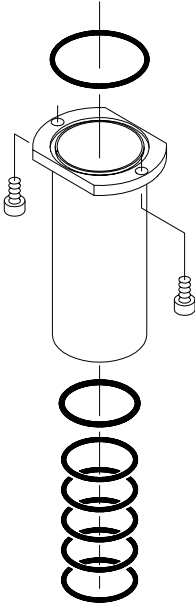

Accessorie for corugated pipe

No. of cap sets needed		Article No.
2 x	F960747NU	F1344 F1152 F1629 F1155

Above-mentioned accessory kit is suitable for all connections of a given model.

Example: 2 x accessory kit F960747NU for e.g. F1344 includes all necessary connections.

1. Rengøring af blandingsbatterier

Hvert blandingsbatteris overflade og funktion efterses og kontrolleres enkeltvis, før de forlader fabrikken.

Følg nedenstående vejledning for at beskytte og bevare overfladen:

Kromoverflader

samt polerede messingoverflader rengøres med en blød klud og væske, syrefri rengøringsmiddel uden slibemiddel eller med sæbevand.

Kalkaflejringer

kan fjernes med almindelig husholdningseddike.

Farvede lakoverflader

mister deres skinnende udseende, hvis de rengøres med midler, der indeholder slibemiddel. Brug kun rent vand eller fortyndet rengøringsmiddel. Kalkaflejringer kan fjernes med almindelig husholdningseddike.

Luftblander

Kalk i luftblander: Anbring luftblanderen i husholdningseddike, og lad den ligge i blød, indtil kalken er opløst.

2. Mål

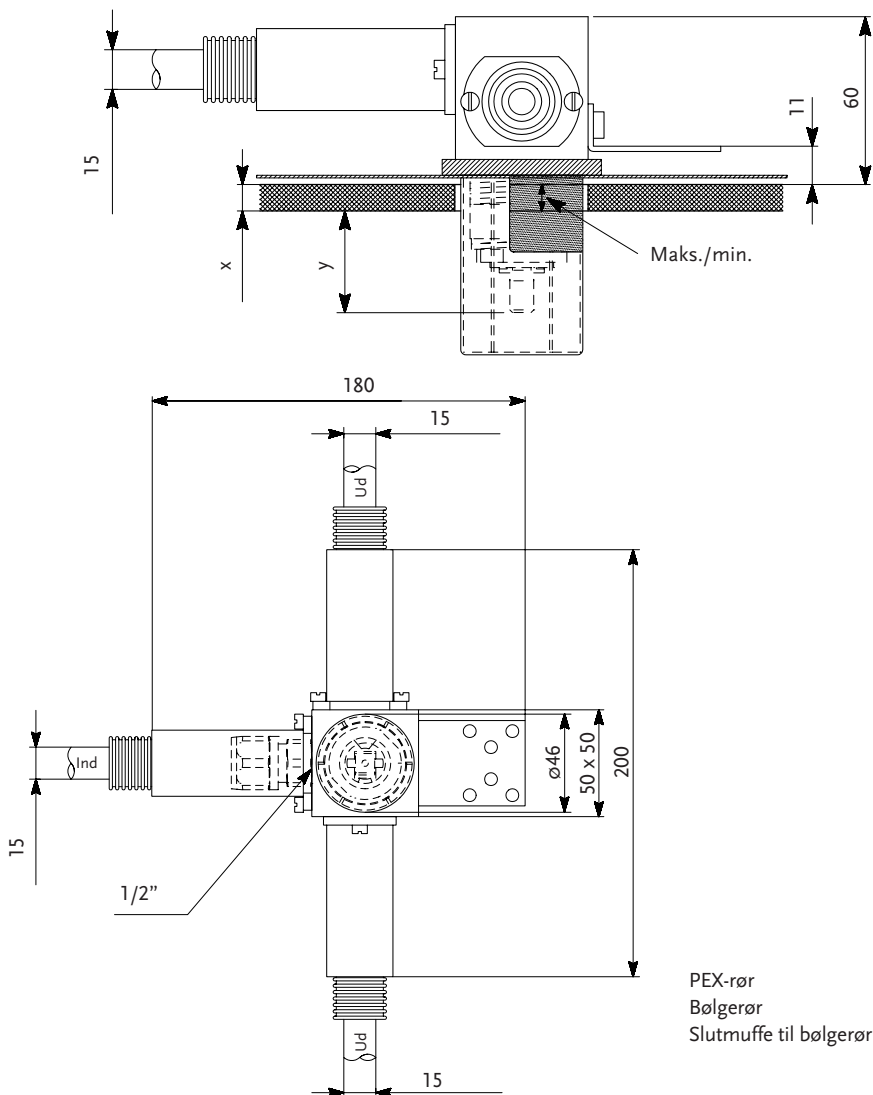

2. Mål

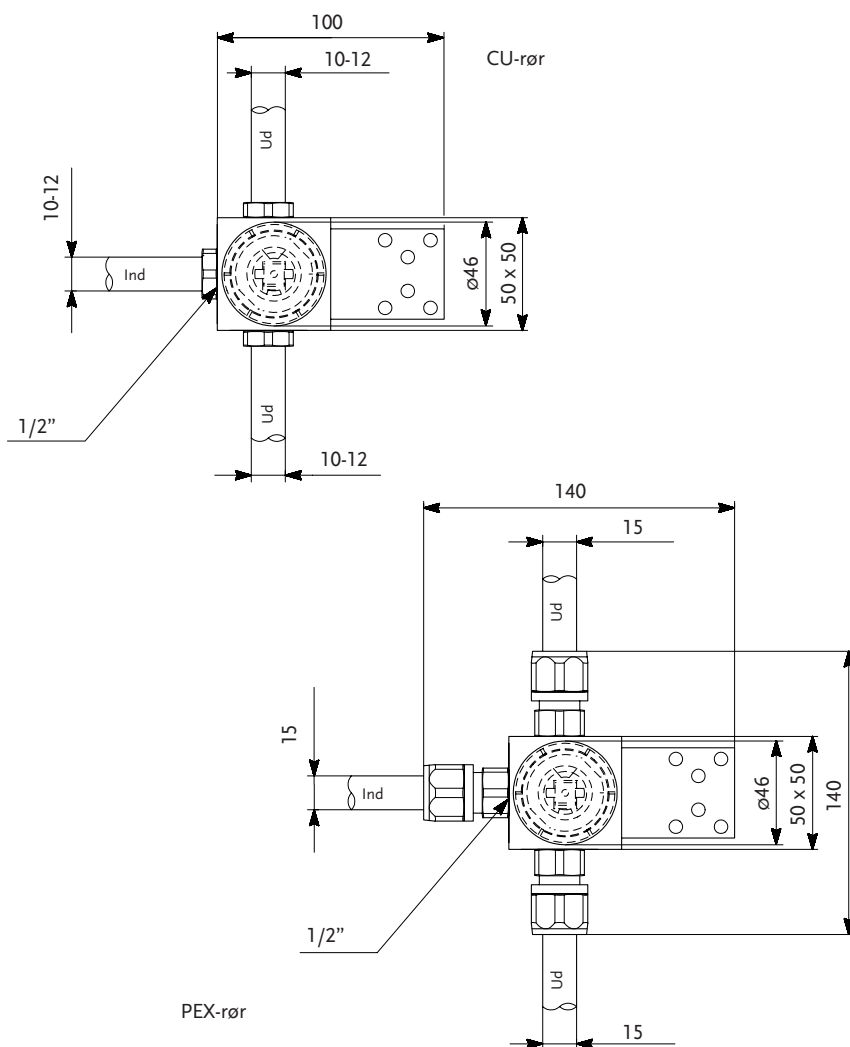

3. Forlængersæt

Vægbeklædningens standardtykkelse = 3 - 13 mm.

I tilfælde af tykkere vægbeklædning kan forlængersæt leveres (se nedenstående tabel):

Flisetykkelse (x)	Mål fra spindelenden til væggen overflade på ydersiden (y)	Blandingsbatteri - type	
3 - 13 mm	44 - 54 mm	Standard	
13 - 23 mm	34 - 44 mm	F960122NU	
23 - 33 mm	24 - 34 mm	F960123NU	
33 - 43 mm	14 - 24 mm	F960124NU	
43 - 53 mm	4 - 14 mm	F960125NU	

4. Vejledning til montering af skjulte blandingsbatterier i letvægtsvæg (18 mm eller 2 x 13 mm)

Udskæring, letvægtsvæg - 18 mm
Udskæring, letvægtsvæg - 2 x 13 mm

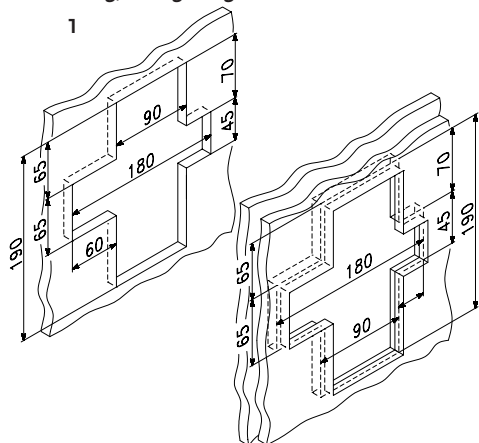

Bestrygning - 1. gang under gummimembranen

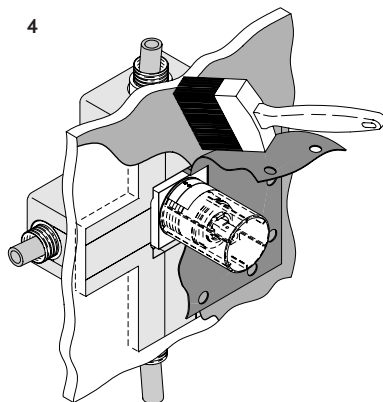

1/2" tilslutning til kobberør, plasticrør eller stålør og samling af styrendåse

Bestrygning - 2. gang over gummimembranen

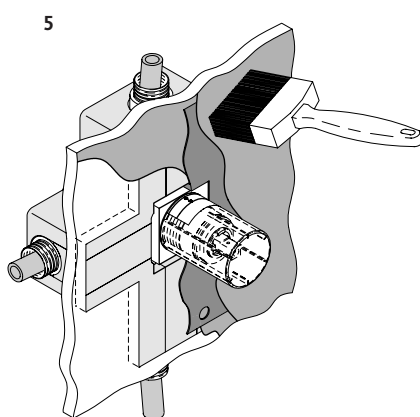
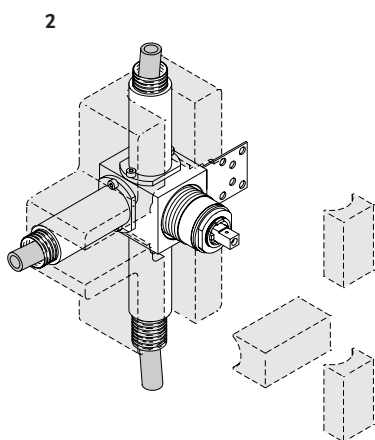

Tilmuring med membran

Vægbeklædning, f.eks. fliser

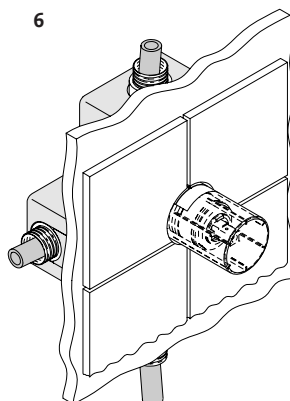
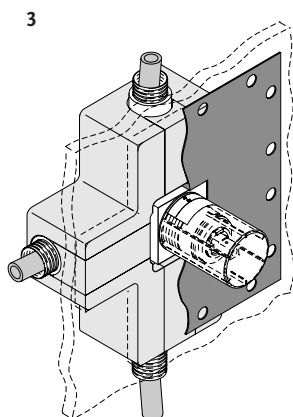

5. Vejledning til montering af skjulte blandingsbatterier i murstensvæg

Udskæring, murværk

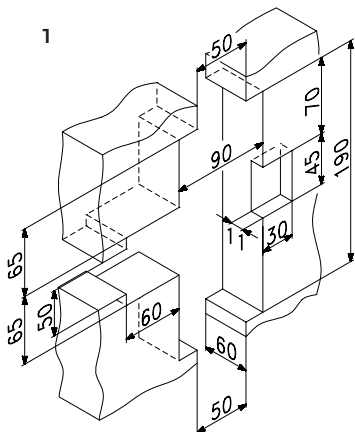

1/2" tilslutning til kobberør, plasticør (PEX-rør) eller stålør

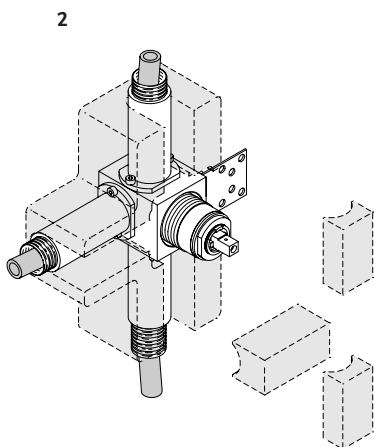

Tilmuring

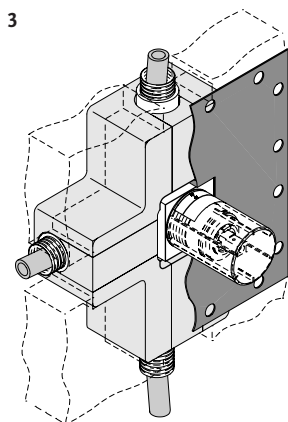

Bestrygning - 1. gang under gummimembranen

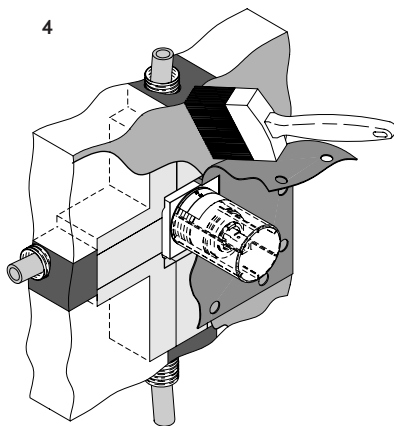

Bestrygning - 2. gang over gummimembranen

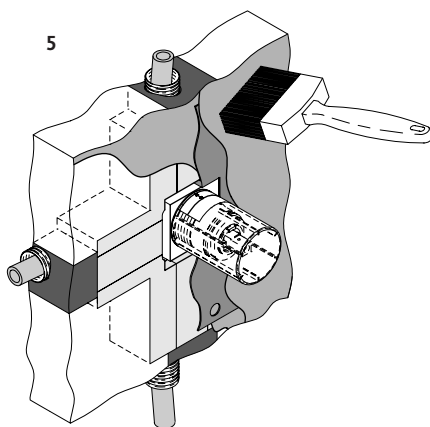

Vægbeklædning, f.eks. fliser

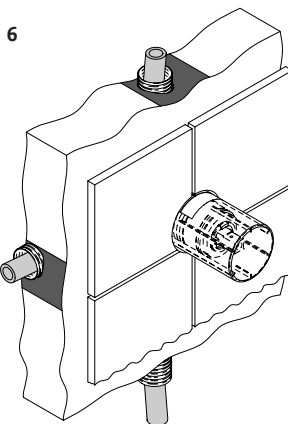

6. Slutsamling

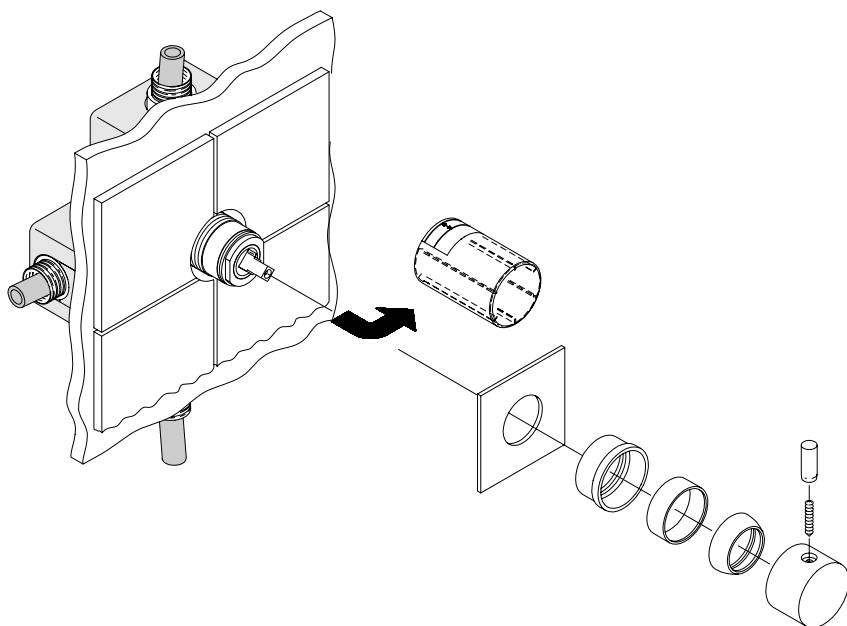

7. Sprængbillede

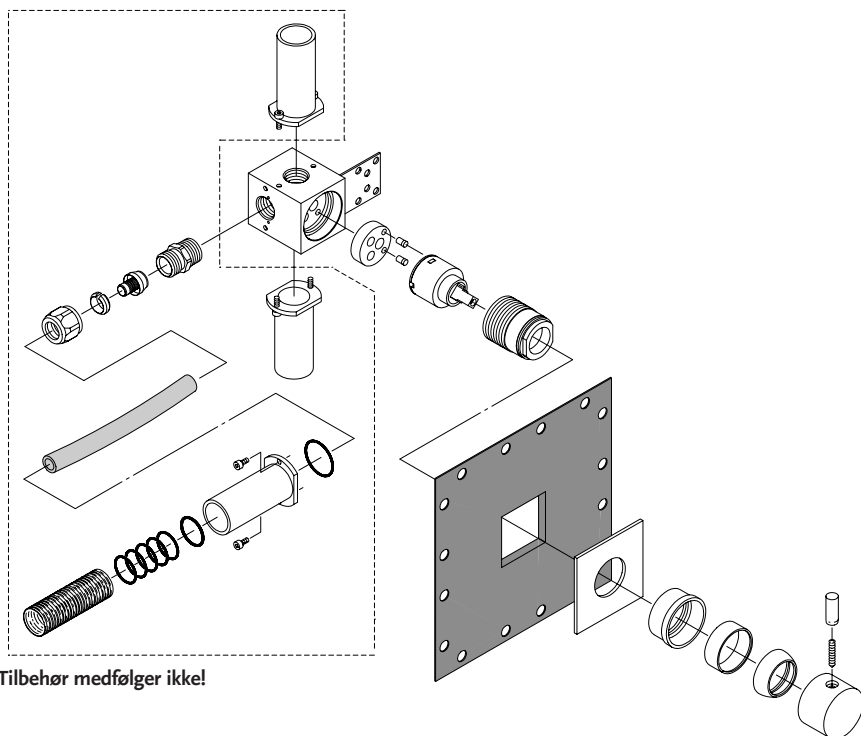

Tilbehør medfølger ikke!

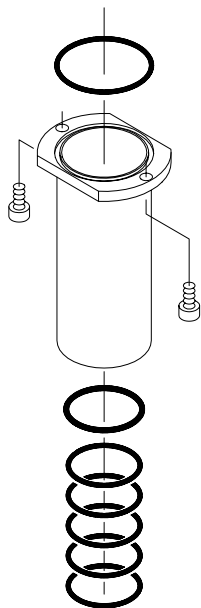

Tilbehør til bølgerør

Antal nødvendige slutmuffer		Artikel nr.
2 x	F960747NU	F1344 F1152 F1629 F1155

Ovennævnte tilbehørssæt er egnet til alle tilslutninger af en given model.

Eksempel: 2 x tilbehørssættet F960747NU til f.eks. F1344 indeholder alle nødvendige tilslutninger.

1. Reinigung der Mischer

Oberfläche und Funktion jedes einzelnen Mischers wurden vor der Auslieferung ab Werk durchgeprüft.

Zum Schutz der Oberfläche beachten Sie bitte die folgenden Hinweise:

Chromoberflächen

und polierte Messingoberflächen müssen mit einem weichen Tuch und säurefreien Flüssigreinigern ohne Scheuermittel bzw. mit einer Seifenlauge gesäubert werden.

Kalkrückstände

können mit handelsüblichem Essig entfernt werden.

Farbige Emailoberflächen

verlieren ihren Glanz, wenn sie mit scheuernden Reinigern gesäubert werden. Benutzen Sie nur reines Wasser oder verdünntes Reinigungsmittel. Kalkrückstände können mit handelsüblichem Essig entfernt werden.

Belüfter

Kalk in Belüftern: Weichen Sie den Belüfter in handelsüblichem Essig ein, bis sich der Kalk löst.

2. Maße

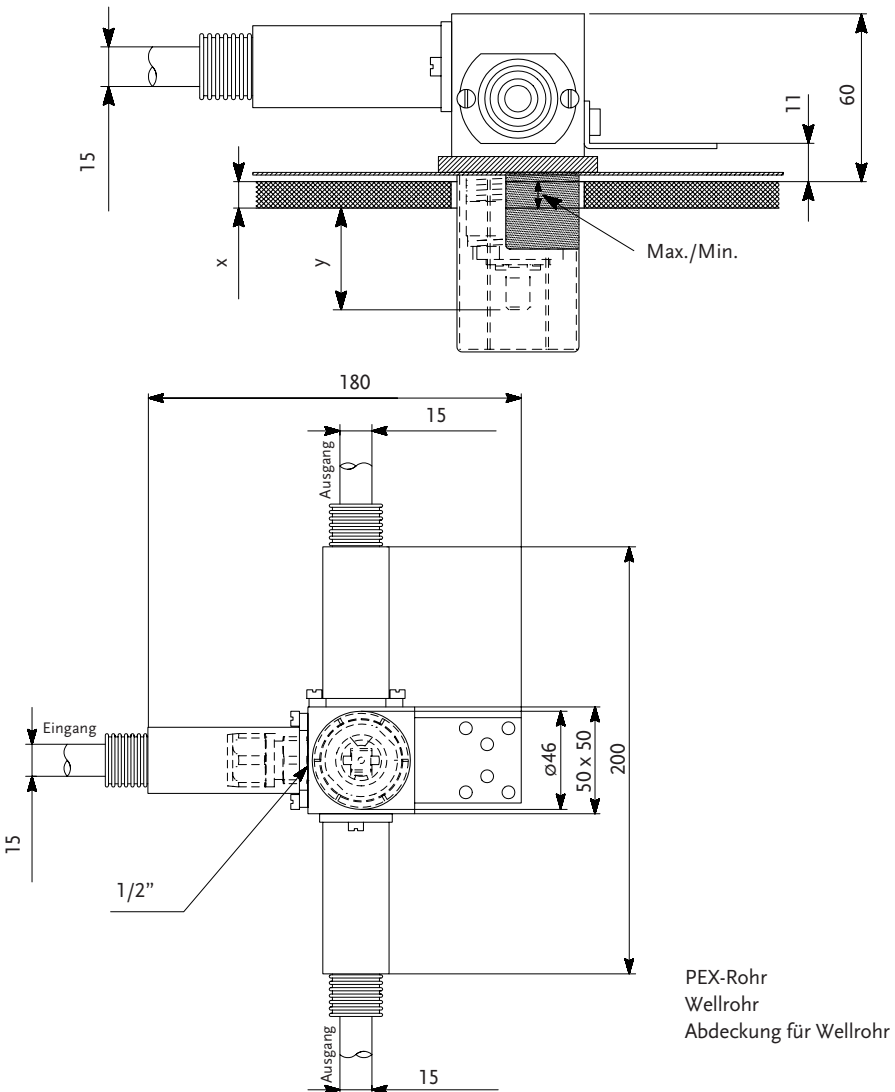

2. Maße

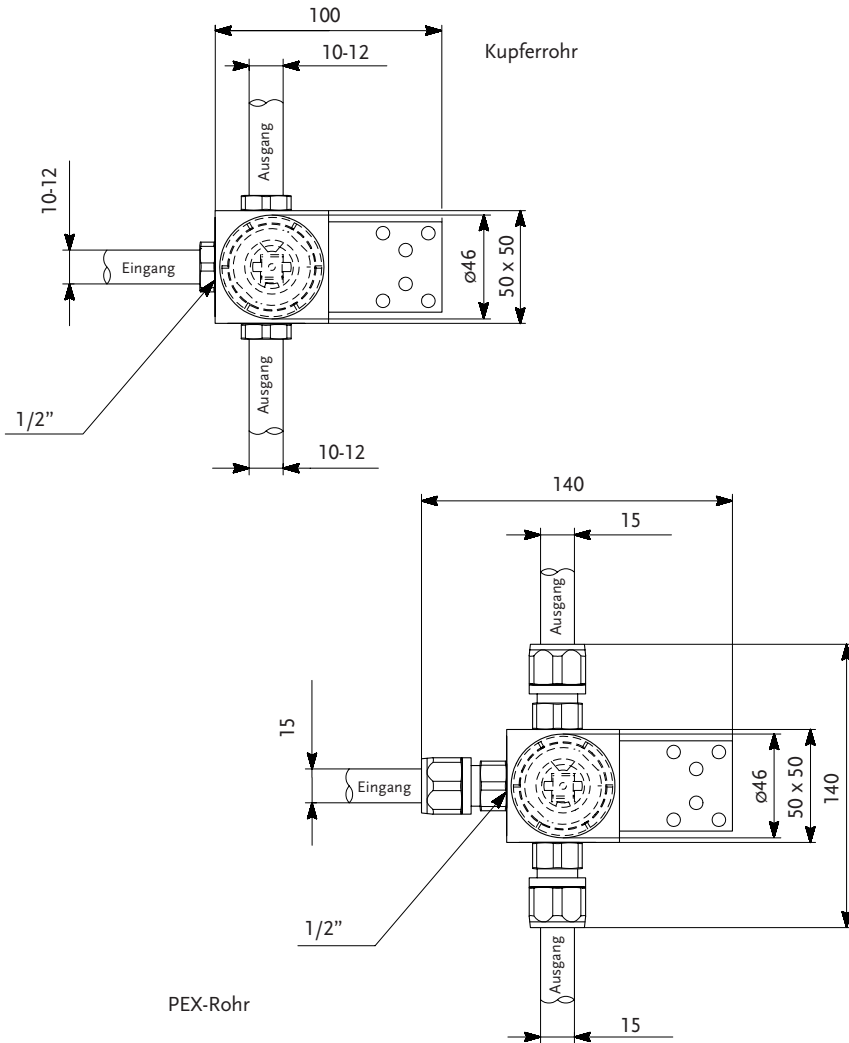

3. Verlängerungssätze

Standardstärke der Wandbedeckung = 3 - 13 mm.

Für stärkere Wandbedeckungen sind Verlängerungssätze lieferbar (siehe nachstehende Tabelle):

Fliesenstärke (x)	Maß von Spindelende zu äußerer Wand- oberfläche (y)	Mischertyp	
		F1344	F1152
3 - 13 mm	44 - 54 mm	Standard	
13 - 23 mm	34 - 44 mm	F960122NU	
23 - 33 mm	24 - 34 mm	F960123NU	
33 - 43 mm	14 - 24 mm	F960124NU	
43 - 53 mm	4 - 14 mm	F960125NU	

4. Installationshinweise für verdeckte Mischer in Leichtbauwänden (18 mm bzw. 2 x 13 mm)

Ausschnitt, Leichtbauwand - 18 mm
 Ausschnitt, Leichtbauwand - 2 x 13 mm

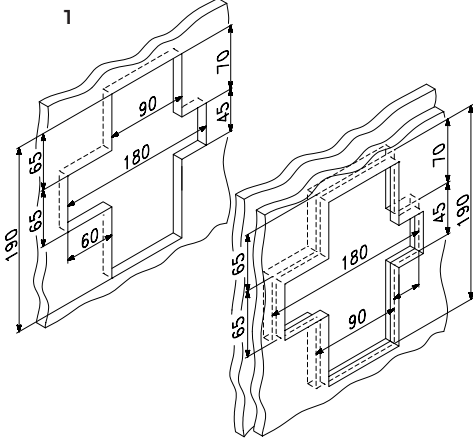

Beschichtung - 1. unter Gummimembrane

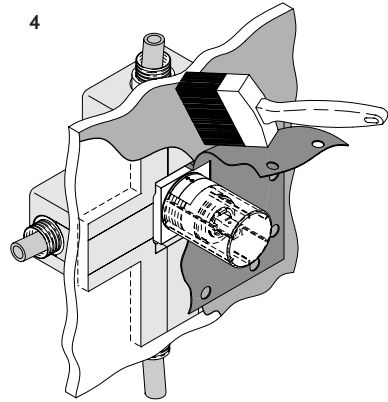

1/2"- Anschluss für Kupfer-, Kunststoff- oder
 Stahlrohre und Styrolbox

Beschichtung - 2. über Gummimembrane

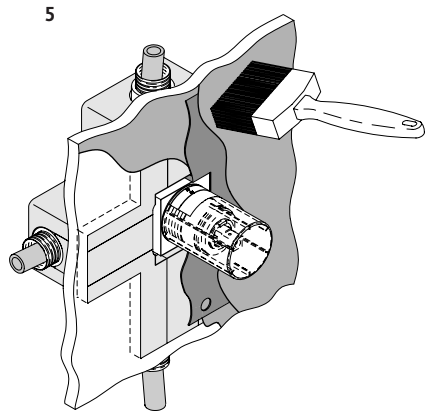
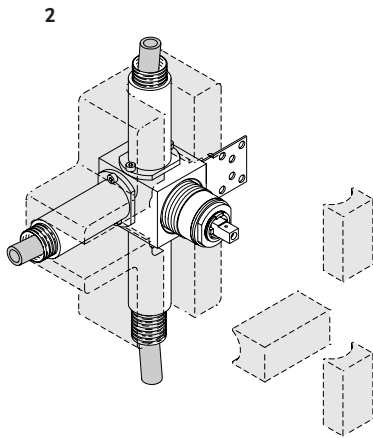

Wandangleichung an Membrane

Wandbedeckung, z.B. Fliesen

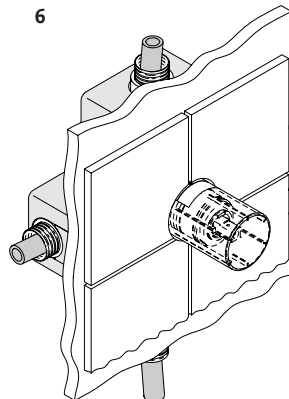
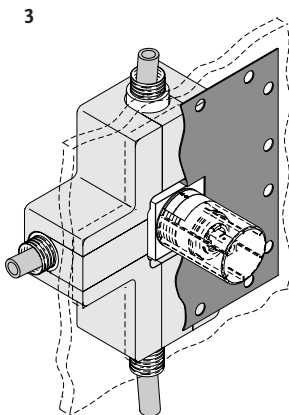

5. Installationshinweise für verdeckte Mischer in gemauerten Wänden

Ausschnitt, Mauerwerk

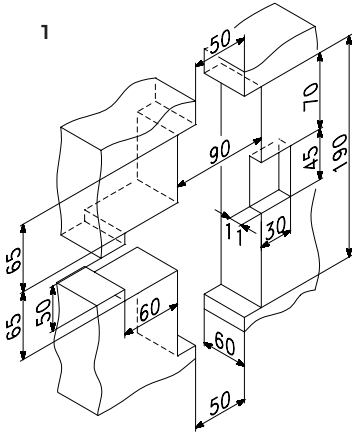

1/2"- Anschluss für Kupfer-, Kunststoff- (PEX-) oder Stahlrohre

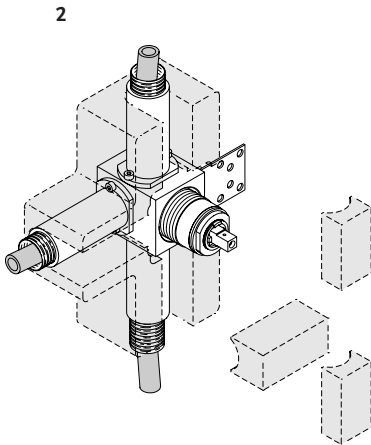

Wandangleichung

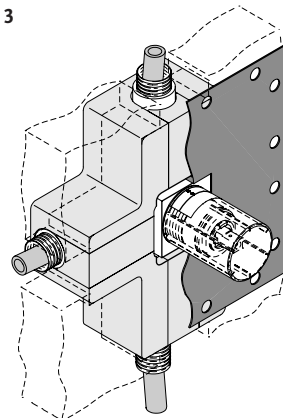

Beschichtung - 1. unter Gummimembrane

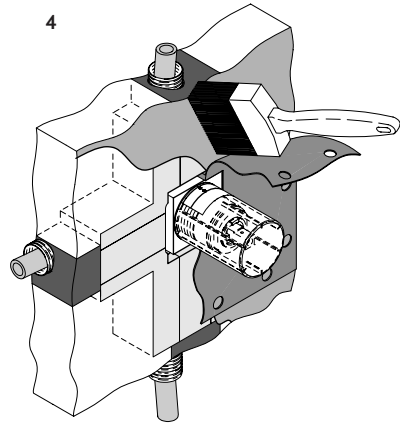

Beschichtung - 2. über Gummimembrane

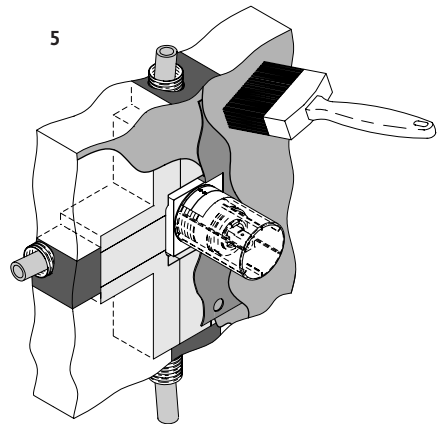

Wandbedeckung, z.B. Fliesen

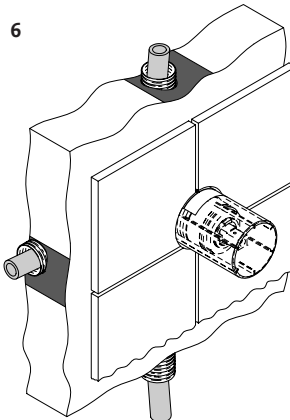

6. Montage

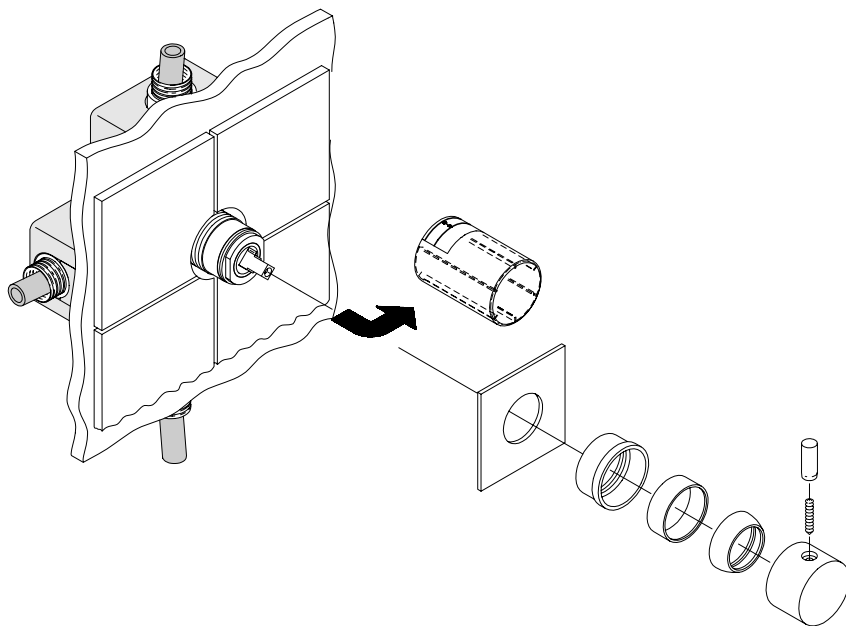

7. Explosionsansicht

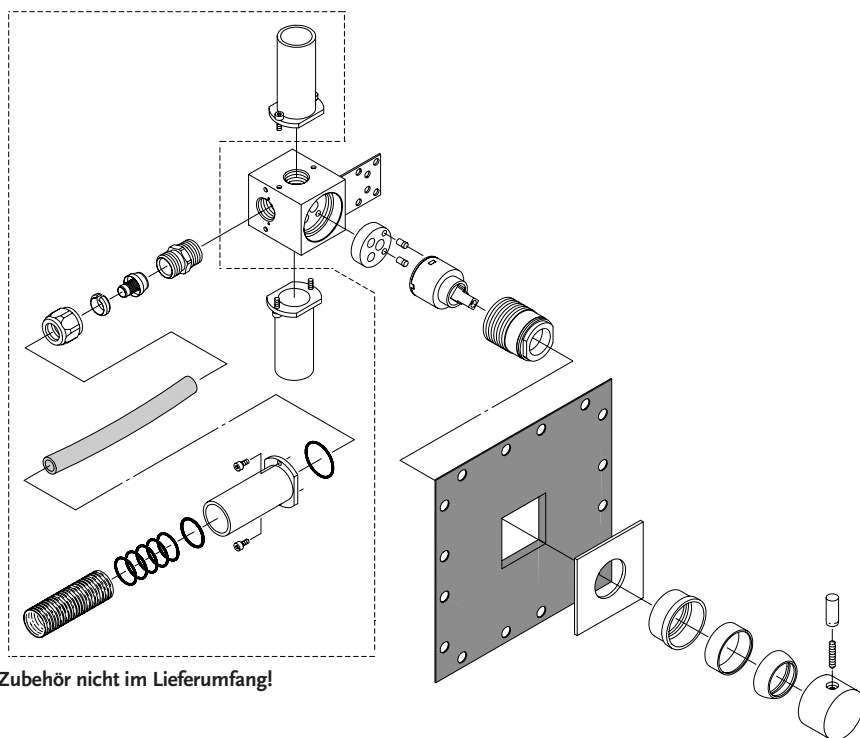

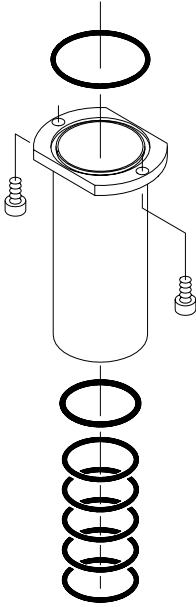

Zubehör für Wellrohr

Anzahl der benötigten Abdeckungssätze		Artikel-Nr.
2 x	F960747NU	F1344 F1152 F1629 F1155

Der obige Zubehörsatz eignet sich für alle Anschlüsse eines bestimmten Modells.

Beispiel: 2 x Zubehörsatz F960747NU für z.B. F1344 enthält alle notwendigen Anschlüsse.

1. Nettoyage des mitigeurs

La surface et le bon fonctionnement de chaque robinetterie ont été vérifiés et contrôlés individuellement avant de quitter de l'usine.

Afin de protéger et de conserver la surface en bon état, il est nécessaire de suivre les instructions indiquées ci-dessous :

Surfaces chromées

Il convient de nettoyer ces surfaces ainsi que le laiton poli avec un chiffon doux et un détergent liquide non acide et non abrasif ou bien avec de l'eau savonneuse.

Surfaces laquées couleurs

En cas d'utilisation de détergent contenant un abrasif, ces surfaces perdent leur brillance. N'utiliser que de l'eau propre ou du détergent dilué. Retirer les résidus de calcaire à l'aide de vinaigre de ménage.

Aérateurs

Calcaire dans les aérateurs : mettre l'aérateur dans du vinaigre de ménage et le laisser tremper jusqu'à ce que le calcaire soit dissout.

Résidus de calcaire

S'enlèvent à l'aide de vinaigre de ménage.

2. Dimensions

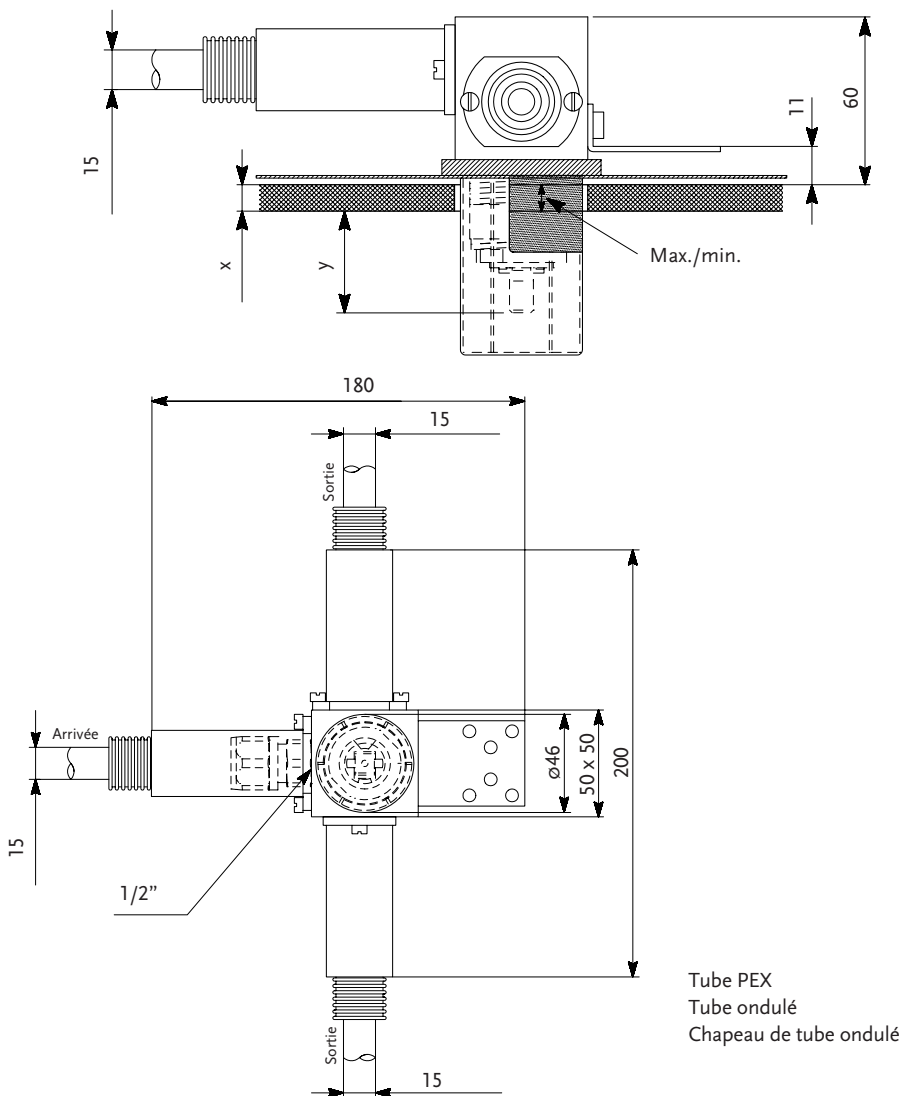

2. Dimensions

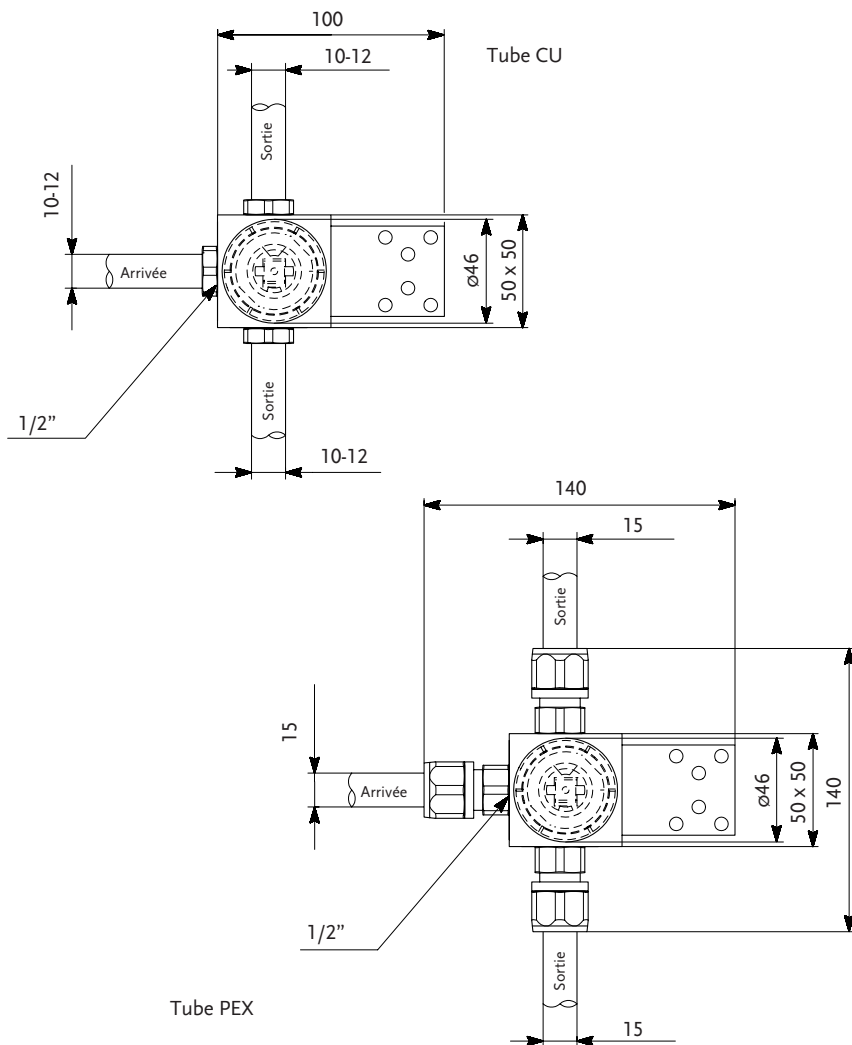

3. Kits d'extension

Épaisseur standard du revêtement mural = de 3 à 13 mm.

En cas de revêtement mural plus épais, des kits d'extension sont disponibles (voir tableau ci-dessous) :

Épaisseur de carreau (x)	Distance de l'extrémité de la tige à la surface extérieure de mur (y)	Type de mitigeur	
		F1344	
		F1152	
		F1629	
		F1155	
3 - 13 mm	44 - 54 mm	Standard	
13 - 23 mm	34 - 44 mm	F960122NU	
23 - 33 mm	24 - 34 mm	F960123NU	
33 - 43 mm	14 - 24 mm	F960124NU	
43 - 53 mm	4 - 14 mm	F960125NU	

4. Instructions de pose de mitigeurs encastrés dans un mur de construction légère (18 mm ou 2 x 13 mm)

Saignée, mur de construction légère - 18 mm
Saignée, mur de construction légère - 2 x 13 mm

Enrobage - 1^{ère} fois sous membrane caoutchouc

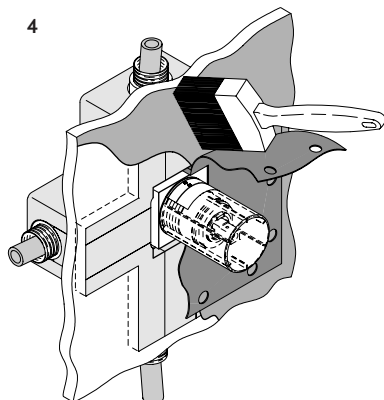
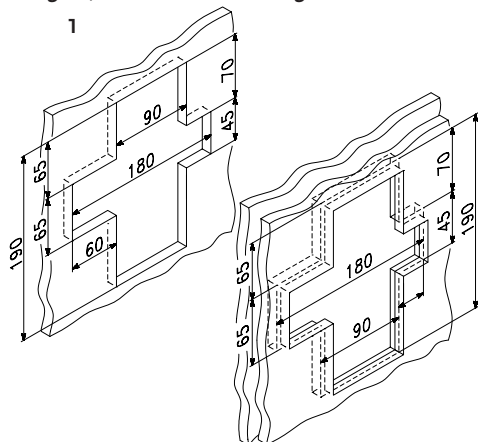

Raccordement 1/2" pour tubes en cuivre, tubes en plastique ou tubes en acier et assemblage de la coque en styrène

Enrobage - 2^{ème} fois sur membrane caoutchouc

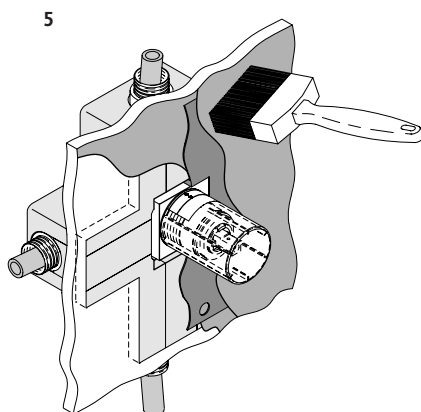
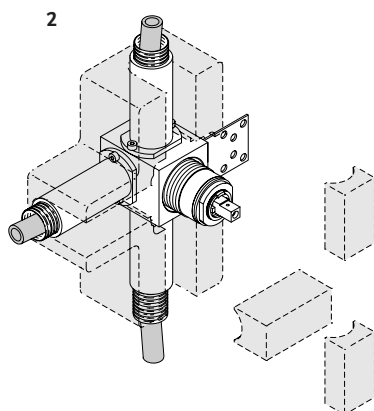

Scellement avec membrane

Revêtement mural, par ex. carrelage

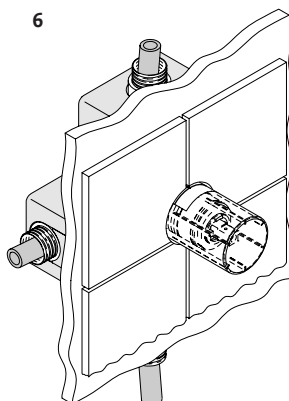
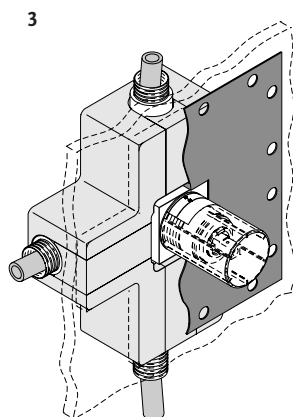

5. Instructions de pose de mitigeurs encastrés dans un mur en briques

Saignée, maçonnerie de brique

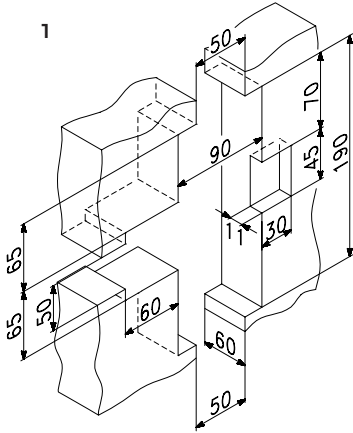

Enrobage - 1^{ère} fois sous membrane caoutchouc

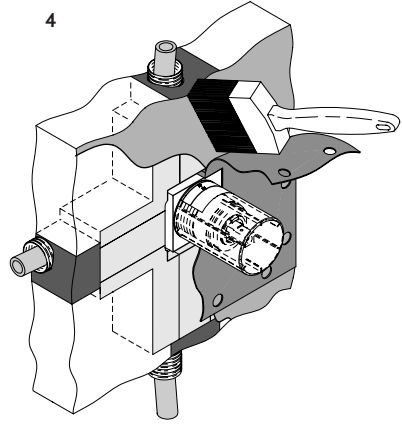

Raccordement 1/2" pour tubes en cuivre, tubes en plastique (tube PEX) ou tubes en acier

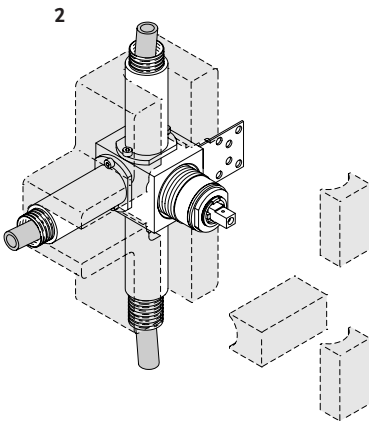

Enrobage - 2^{ème} fois sur membrane caoutchouc

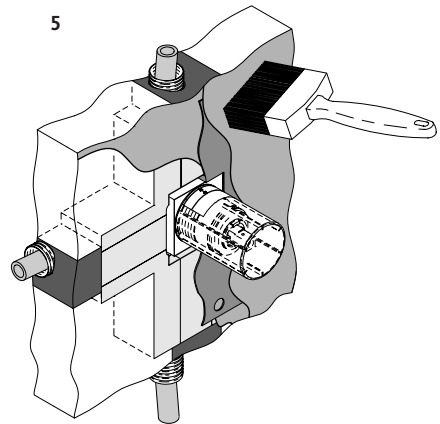

Scellement

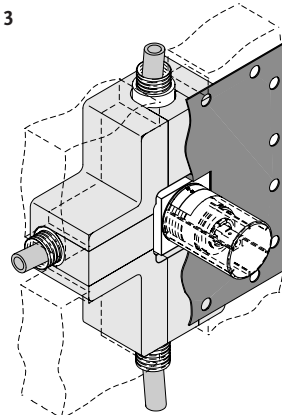

Revêtement mural, par ex. carrelage

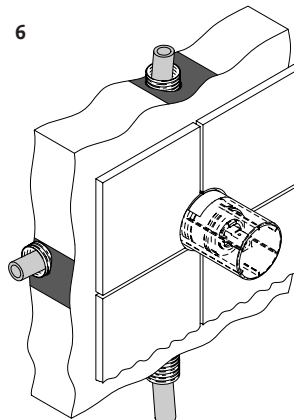

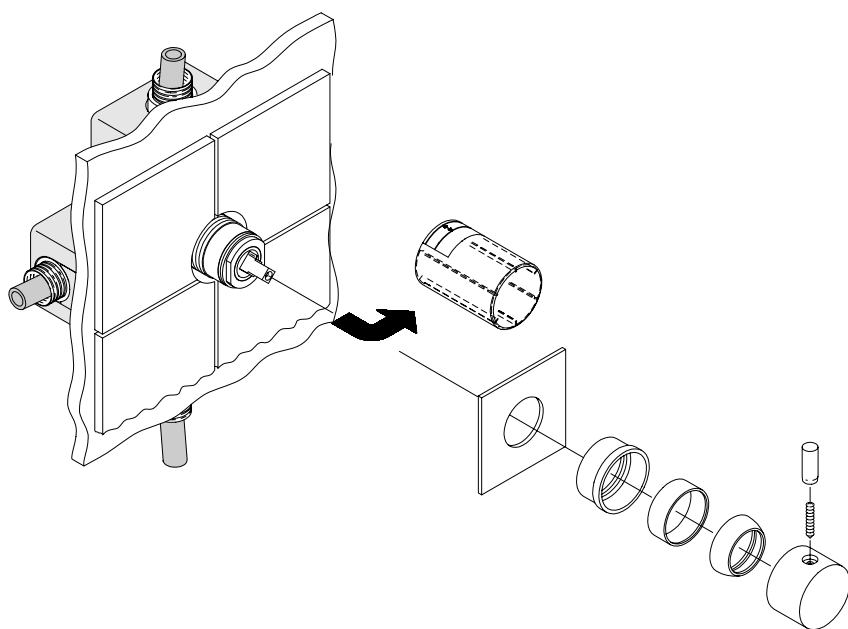
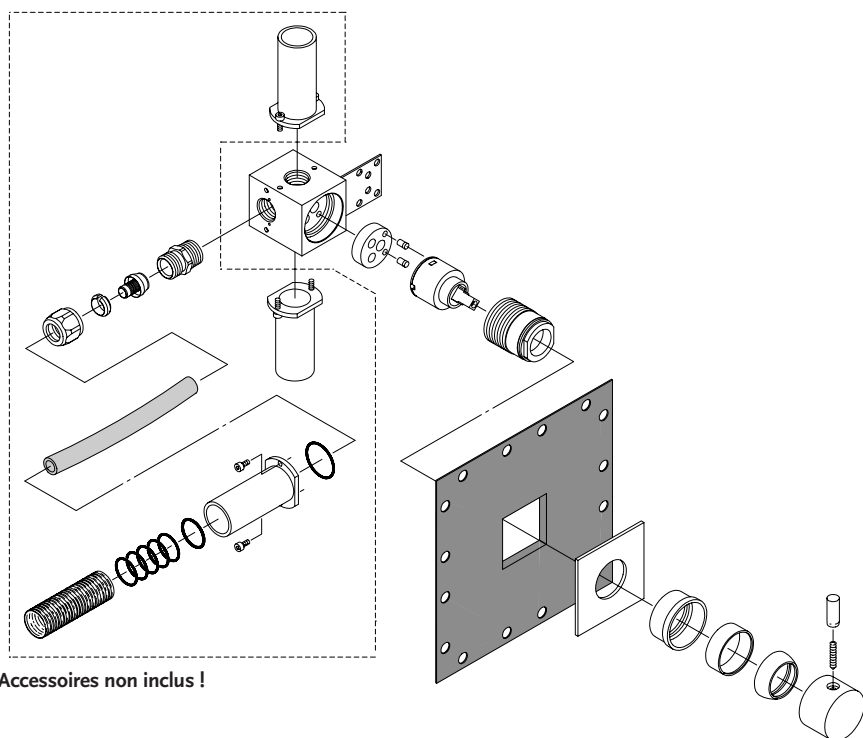
6. Assemblage final**7. Vue éclatée**

Accessoires non inclus !

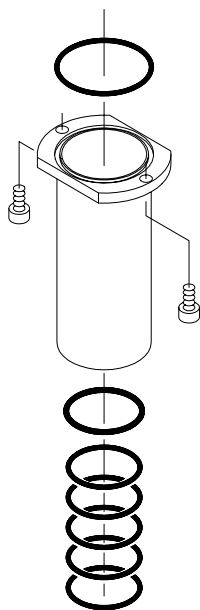

Accessoires pour tube ondulé

Nombre de jeux de chapeaux nécessaires		Réf. n°
2 x	F960747NU	F1344 F1152 F1629 F1155

Le kit d'accessoires mentionné ci-dessus convient à tous les raccordements d'un modèle donné.

Exemple : Le kit d'accessoires F960747NU destiné par exemple au modèle F1344 contient tous les raccords nécessaires.

1. Pulizia dei miscelatori

Tutti i miscelatori sono stati ispezionati e controllati uno a uno per verificarne la superficie e il funzionamento prima di lasciare gli stabilimenti dalla fabbrica.

Al fine di proteggere e mantenere la superficie in buone condizioni, osservare le istruzioni di seguito riportate:

Le superfici cromate

e quelle di ottone lucido devono essere pulite con un panno morbido e detersivi liquidi privi di acidi e sostanze abrasive, oppure con acqua saponata.

I residui calcarei

possono essere rimossi con comune aceto da cucina.

Le superfici smaltate colorate

perderanno lucentezza se pulite con sostanze abrasive. Usare soltanto acqua pulita o detersivi diluiti. Per eliminare i residui di calcare servirsi di comune aceto da cucina.

Aeratori

Calcare negli aeratori: immergere l'aeratore in aceto da cucina fino alla completa dissoluzione del calcare.

2. Dimensioni

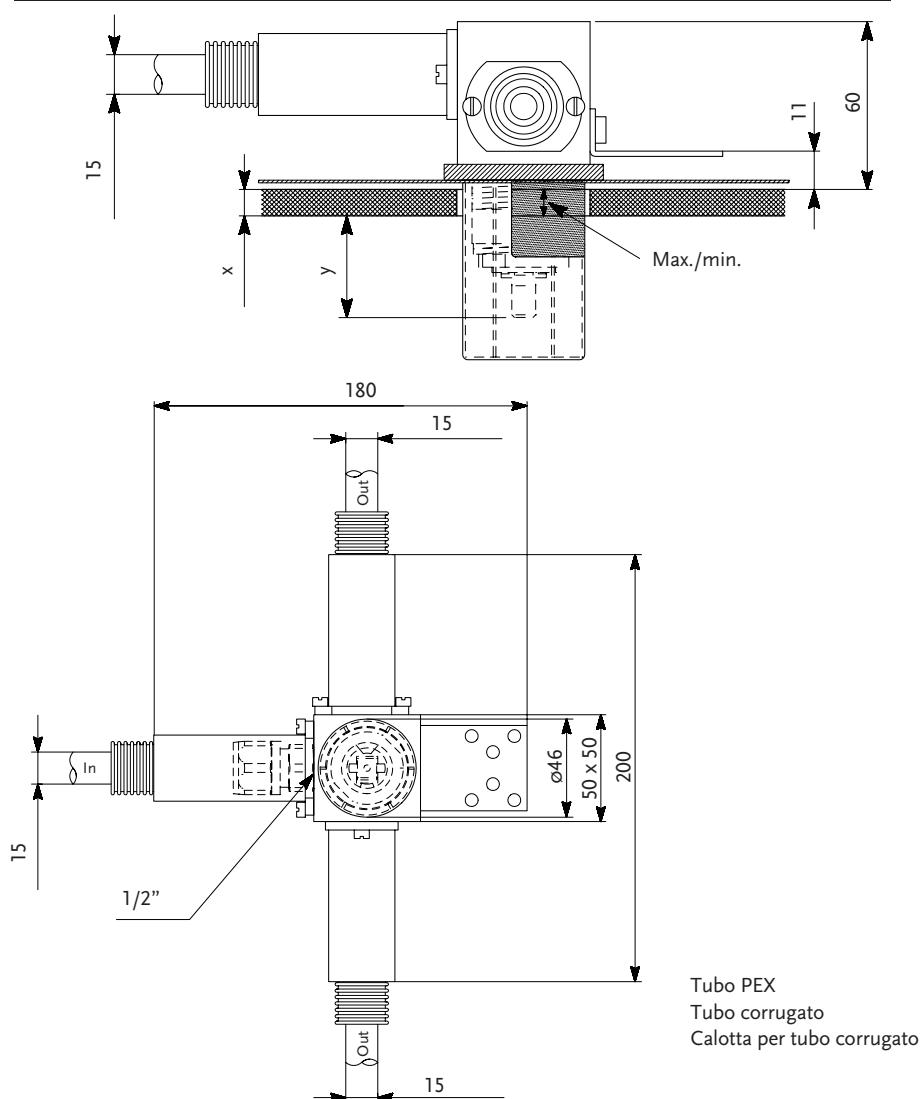

2. Dimensioni

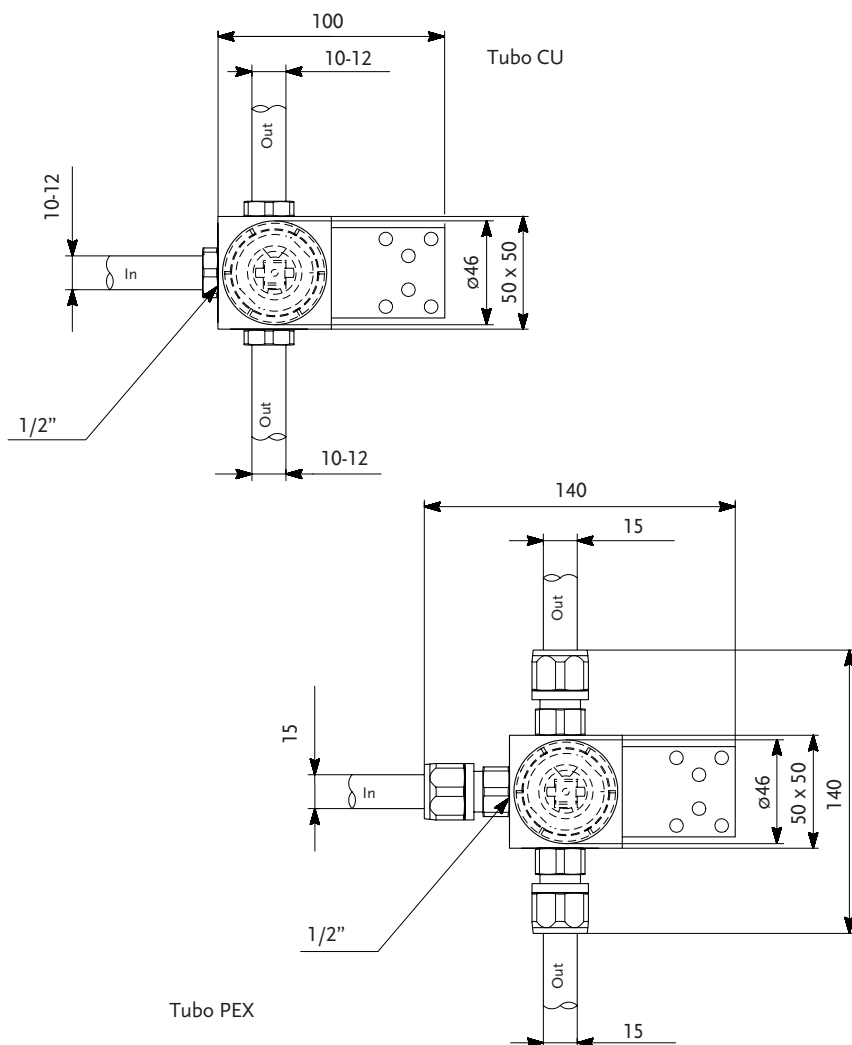

3. Kit di prolunga

Spessore standard del rivestimento parete = 3 - 13 mm.

In caso di rivestimento più spesso, sono disponibili kit di prolunga (vedere la tabella di seguito):

Spessore piastrelle (x)	Dimensioni dall'estremità dell'asta alla superficie esterna della parete (y)	Tipo di miscelatore	
		F1344	F1152
3 - 13 mm	44 - 54 mm	Standard	
13 - 23 mm	34 - 44 mm	F960122NU	
23 - 33 mm	24 - 34 mm	F960123NU	
33 - 43 mm	14 - 24 mm	F960124NU	
43 - 53 mm	4 - 14 mm	F960125NU	

4. Indicazioni per il montaggio dei miscelatori interni in parete leggera (13 mm o 2 x 13 mm)

Sezione, parete leggera - 13 mm
Sezione, parete leggera - 2 x 13 mm

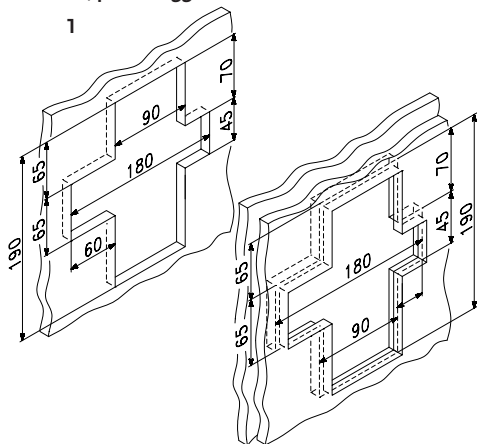

Rivestimento - La prima mano sotto la membrana di gomma

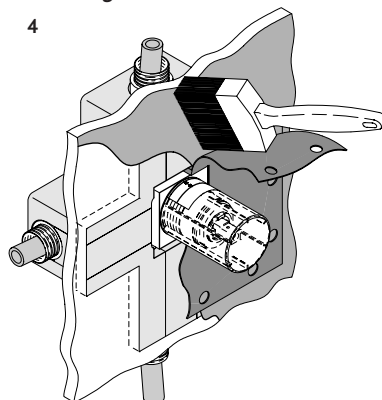

Raccordo 1/2" per condutture di rame, di plastica o d'acciaio e montaggio della scatola di stirene

Rivestimento - La seconda mano sopra la membrana di gomma

2

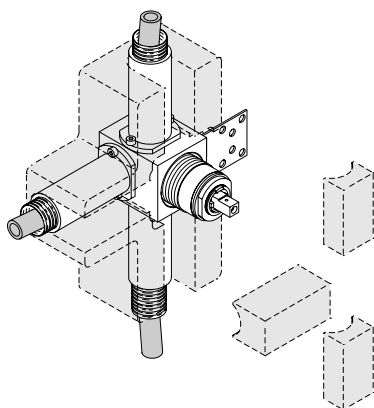

5

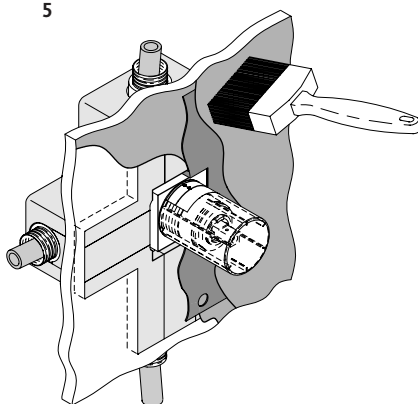

Muratura con membrana

Rivestimento parete, piastrellatura

3

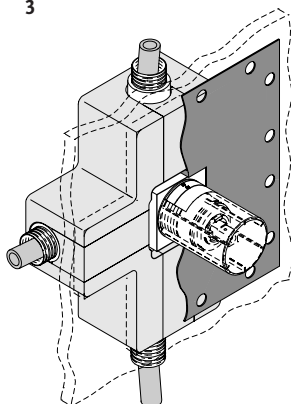

6

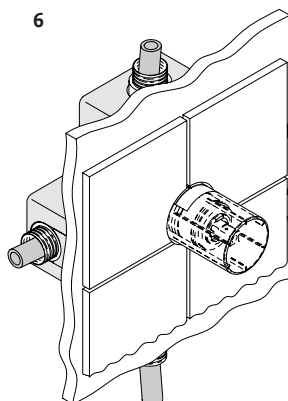

5. Indicazioni per il montaggio dei miscelatori interni in pareti di mattoni

Sezione, muratura in mattoni

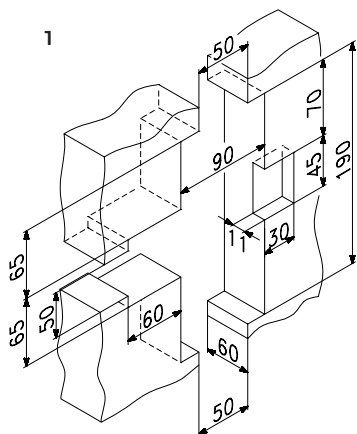

Rivestimento - La prima mano sotto la membrana di gomma

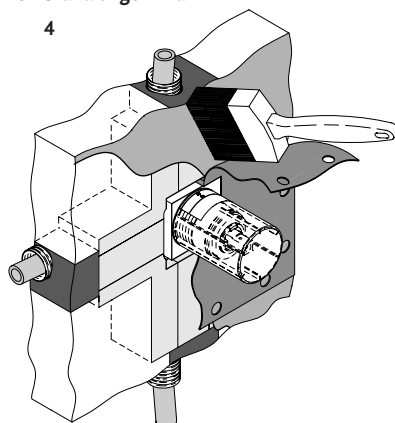

Raccordo 1/2" per tubi di rame, di plastica (tubo PEX) o di acciaio

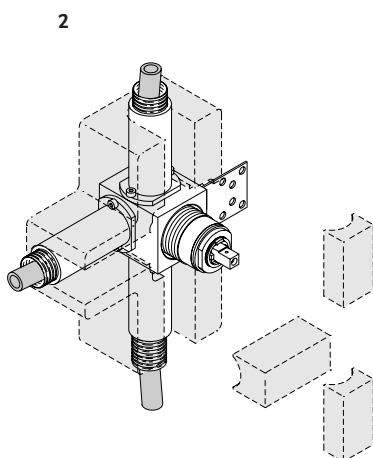

Rivestimento - La seconda mano sopra la membrana di gomma

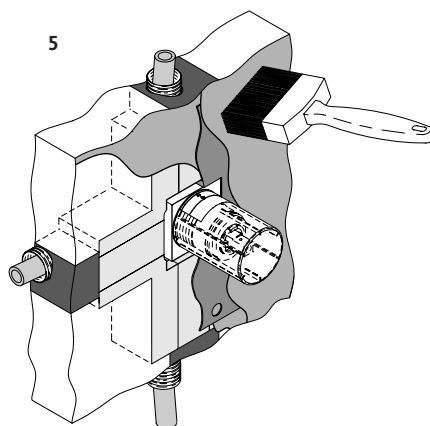

Muratura

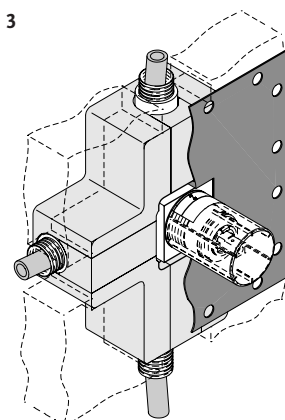

Rivestimento parete, piastrellatura

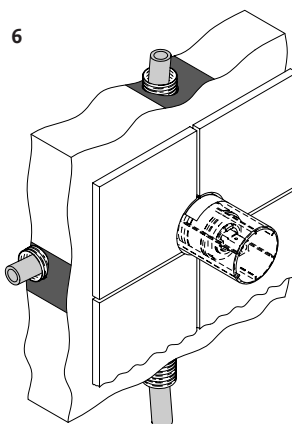

6. Montaggio finale

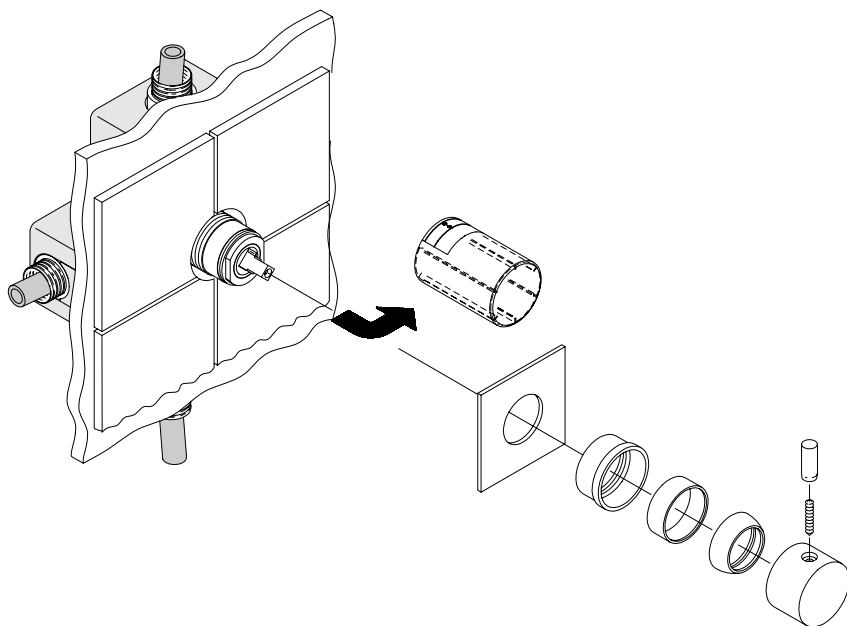

7. Esploso

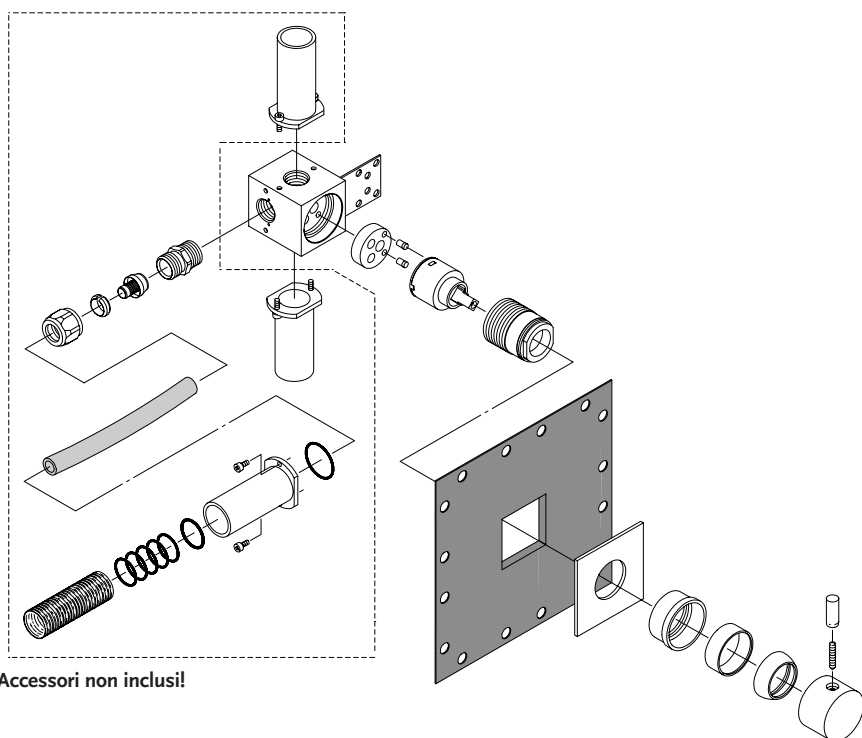

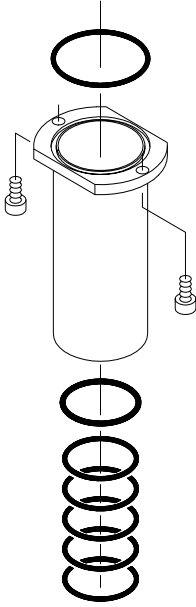

Accessori per tubo corrugato

N. di set calotte necessario		Articolo n.
2 x	F960747NU	F1344 F1152 F1629 F1155

Il kit di accessori sopra menzionato è idoneo per tutte le connessioni di un determinato modello.

Esempio: Il kit di accessori F960747NU per F1344 include tutte le connessioni necessarie.

1. Limpieza de los mezcladores

La superficie y la función de cada mezclador han sido inspeccionadas y comprobadas una por una, antes de salir de fábrica.

Para proteger y conservar la superficie, siga las instrucciones siguientes:

Superficies cromadas

al igual que las superficies doradas, de bronce pulido, deben limpiarse con un paño suave y productos de limpieza no ácidos ni abrasivos, o con agua jabonosa.

Residuos de cal

pueden eliminarse con vinagre común de uso doméstico.

Superficies esmaltadas de color

perderán su aspecto brillante si se limpian con productos que contengan abrasivos. Use únicamente agua limpia o un detergente diluido. Los residuos de cal pueden eliminarse con vinagre común de uso doméstico.

Aireadores

Cal en los aireadores: Sumerja el aireador en vinagre de uso doméstico y déjelo en remojo hasta que se disuelva la cal.

2. Dimensiones

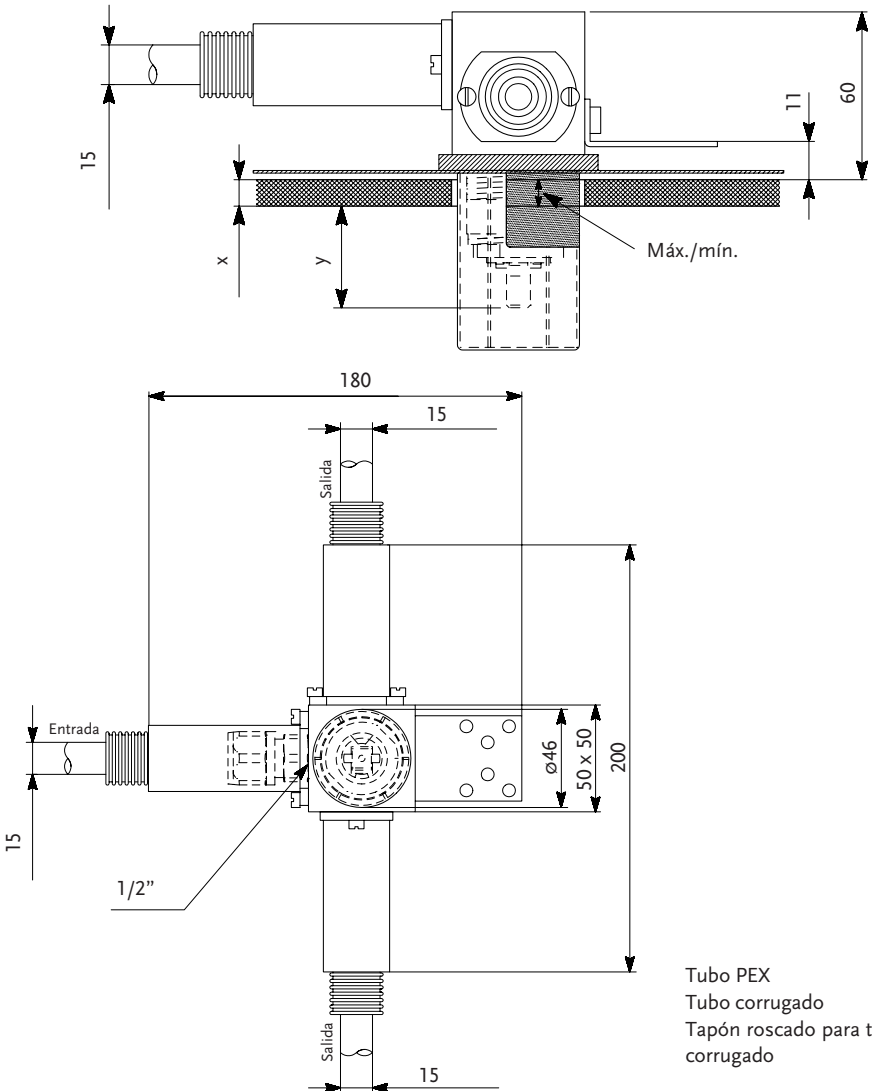

2. Dimensiones

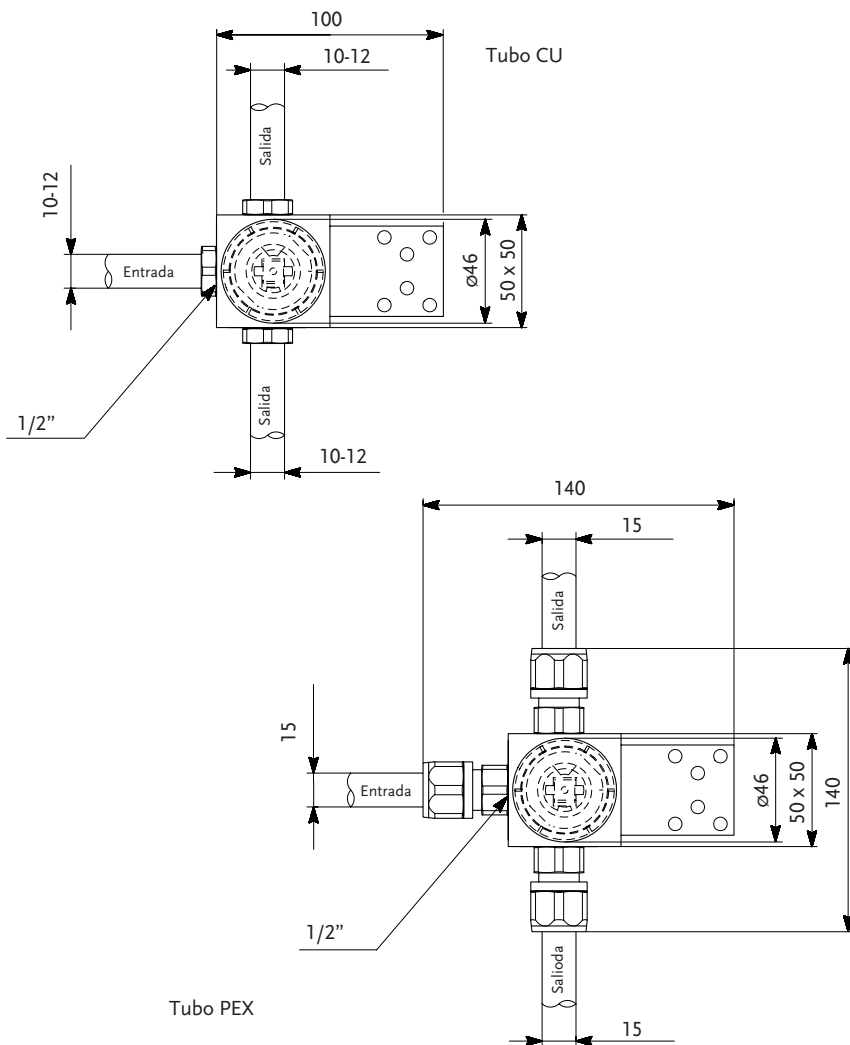

3. Kits de prolongación

Grosor estándar para revestimiento de muros = 3 - 13 mm.

En caso de un revestimiento de muros más grueso, se pueden suministrar kits de prolongación (consulte la siguiente tabla):

Grosor del azulejo (x)	Medida desde el extremo del eje hasta la superficie exterior de la pared (y)	Tipo de mezclador	
		F1344	F1152
		F1629	F1155
3 - 13 mm	44 - 54 mm	Estándar	
13 - 23 mm	34 - 44 mm	F960122NU	
23 - 33 mm	24 - 34 mm	F960123NU	
33 - 43 mm	14 - 24 mm	F960124NU	
43 - 53 mm	4 - 14 mm	F960125NU	

4. Directrices para el montaje de mezcladores empotrados en paredes delgadas (18 mm o 2 x 13 mm)

Desgastado, pared delgada - 18 mm
Desgastado, pared delgada - 2 x 13 mm

Revestimiento - 1ª vez bajo la membrana de caucho

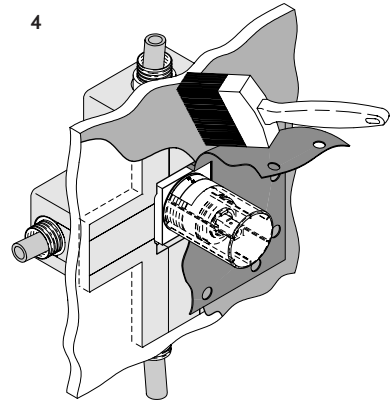
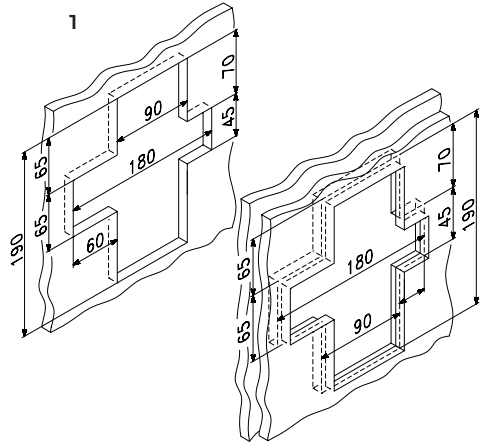

1/2" conexión para tubos de cobre, tubos de plástico, o tubos de acero y montaje de caja de estireno

Revestimiento - 2ª vez sobre la membrana de caucho

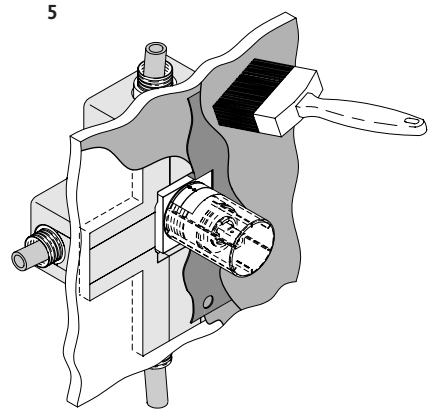
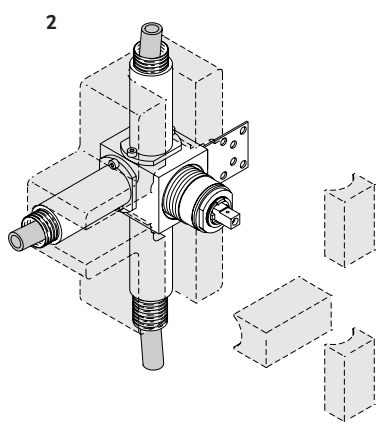

Recubrimiento con membrana

Revestimiento, p.ej., azulejos

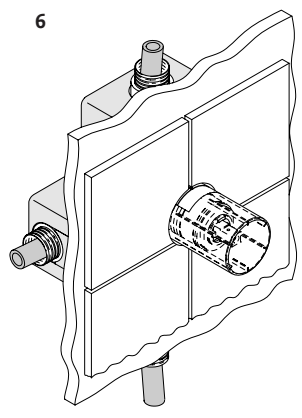
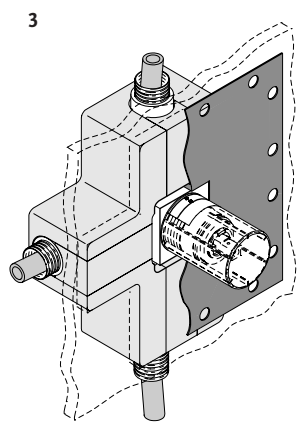

5. Directrices para el montaje de mezcladores empotrados en paredes de ladrillo

Desgastada, obra de ladrillo

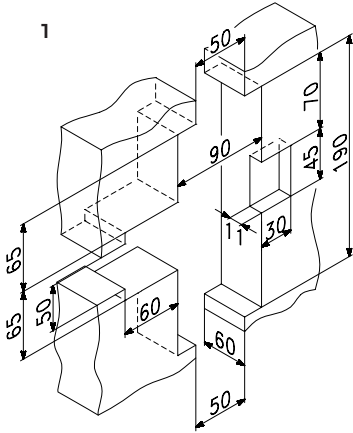

Revestimiento - 1ª vez bajo la membrana de caucho

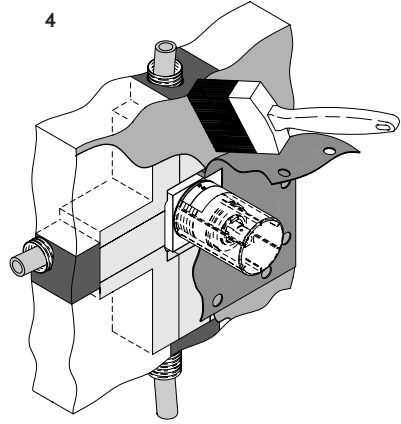

1/2" conexión para tubos de cobre, tubos de plástico (tubo PEX), o tubos de acero

2

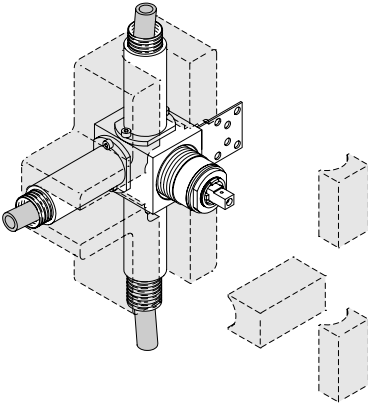

Revestimiento - 2ª vez sobre la membrana de caucho

5

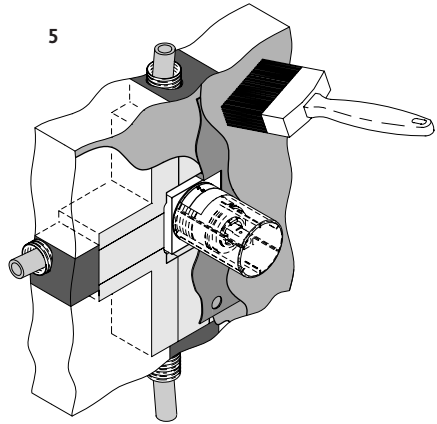

Recubrimiento

3

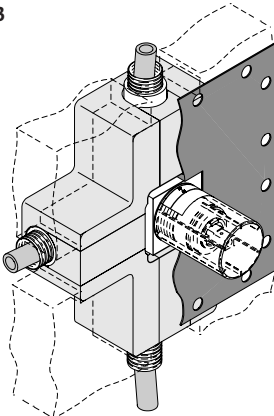

Revestimiento, p.ej., azulejos

6

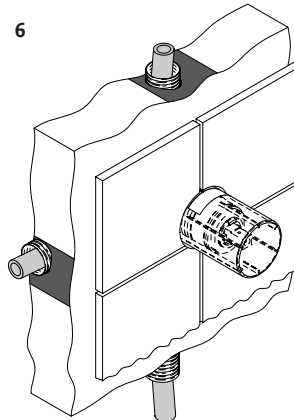

6. Montaje final

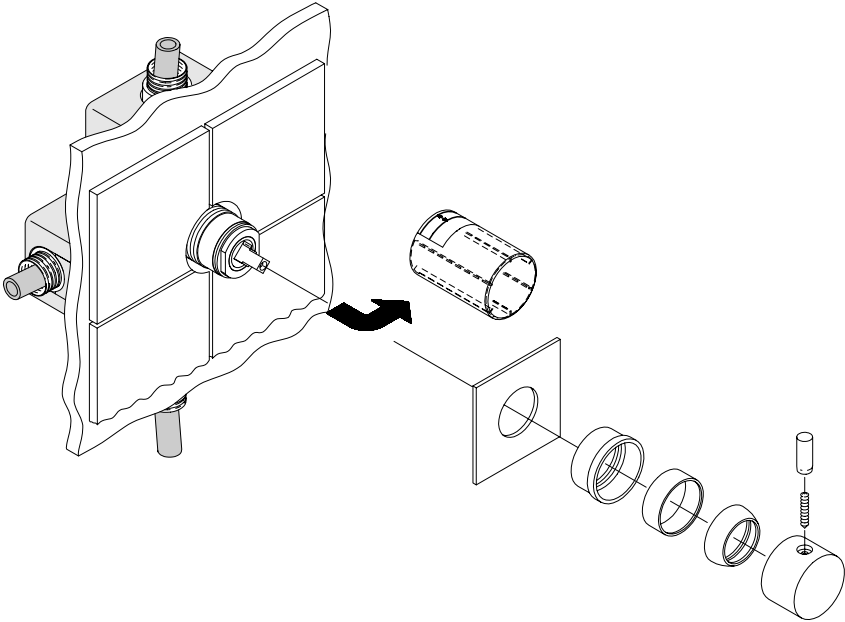

7. Vista detallada

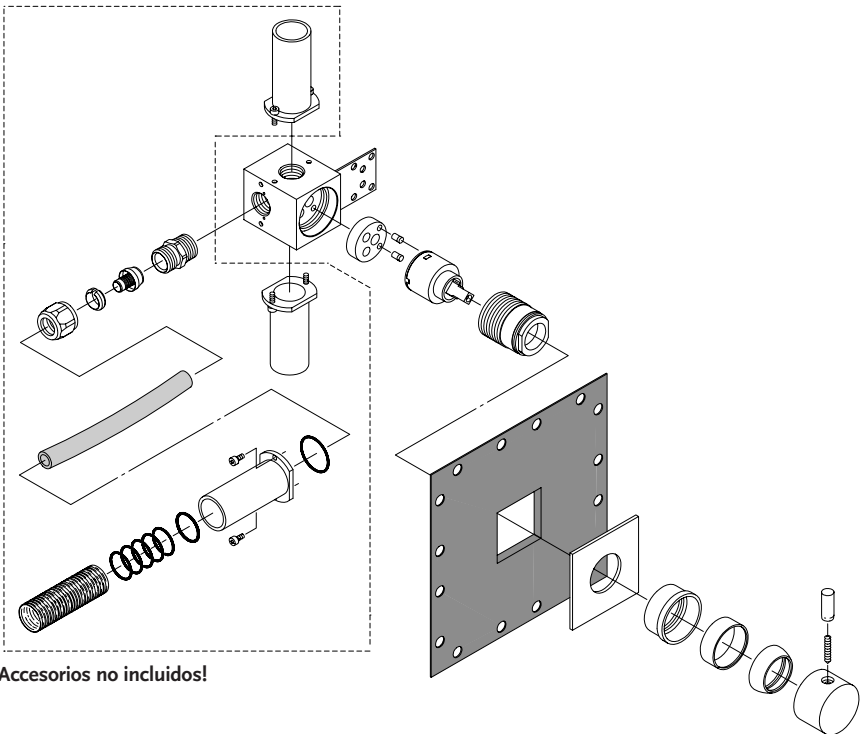

¡Accesorios no incluidos!

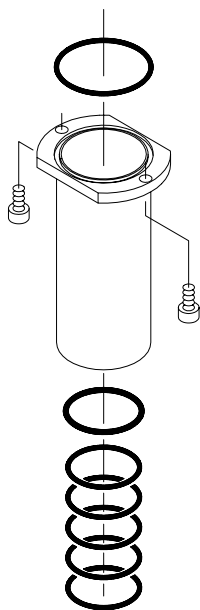

Accesorios para tubo corrugado

Nº de juegos de tapones roscados necesarios		Artículo n°
2 x	F960747NU	F1344 F1152 F1629 F1155

El kit de accesorios arriba mencionado es apropiado para todas las conexiones de un modelo determinado.

Ejemplo: El kit de accesorios F960747NU, p.ej., para F1344 incluye todas las conexiones necesarias.

1. Limpeza das misturadoras

A superfície e o funcionamento de cada misturadora foram inspeccionados, tendo as misturadoras sido verificadas uma a uma antes de saírem da fábrica.

Para proteger e conservar a superfície, siga as instruções abaixo:

Superfícies cromadas

As superfícies cromadas bem como as superfícies de latão polidas devem ser limpas com um pano macio e materiais de limpeza líquidos, não ácidos e sem abrasivos ou com água com sabão.

Superfícies esmaltadas coloridas

Estas superfícies perderão o seu aspecto brilhante se forem limpas com materiais contendo abrasivos. Utilize apenas água limpa ou detergente diluído. Os resíduos de calcário podem ser retirados com o vulgar vinagre caseiro.

Arejadores

Calcário nos arejadores: mergulhe o arejador em vinagre caseiro até o calcário dissolver.

Resíduos de calcário

Os resíduos de calcário podem ser retirados com o vulgar vinagre caseiro.

2. Dimensões

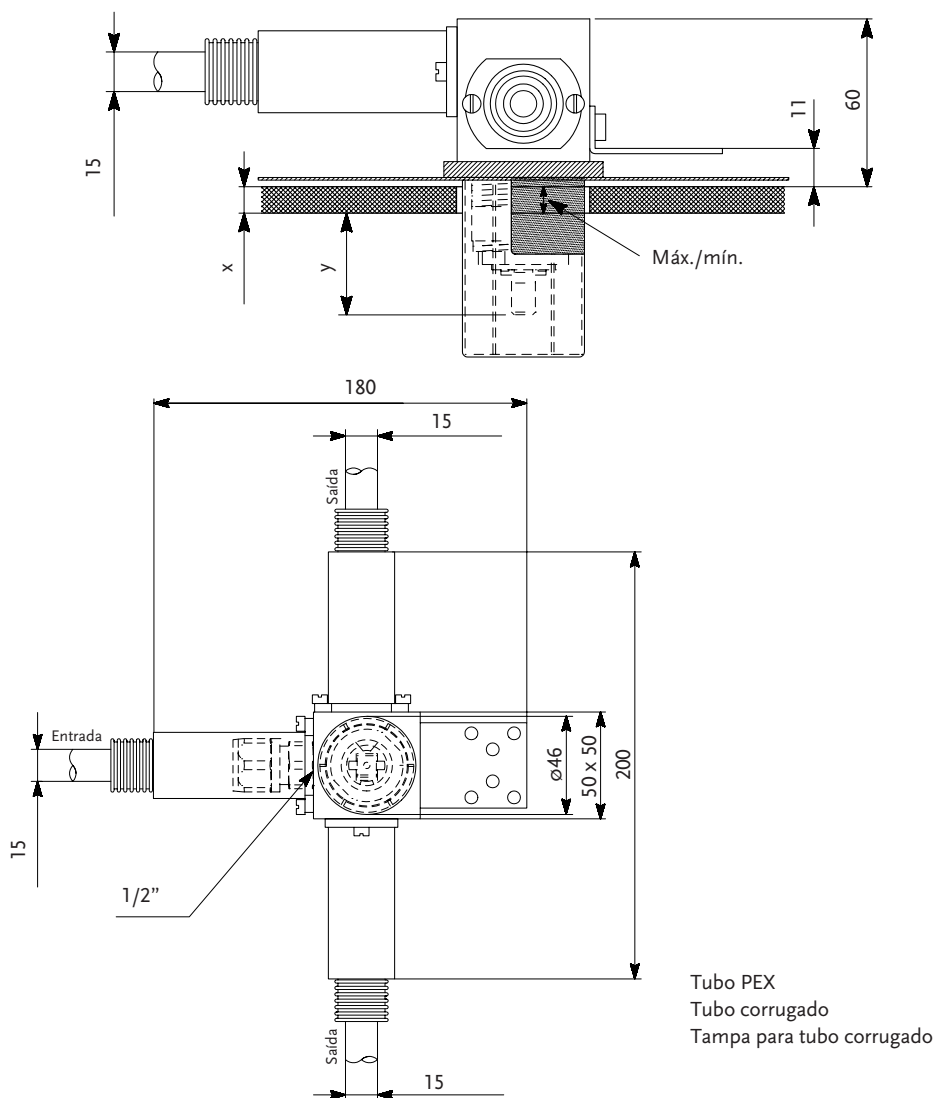

2. Dimensões

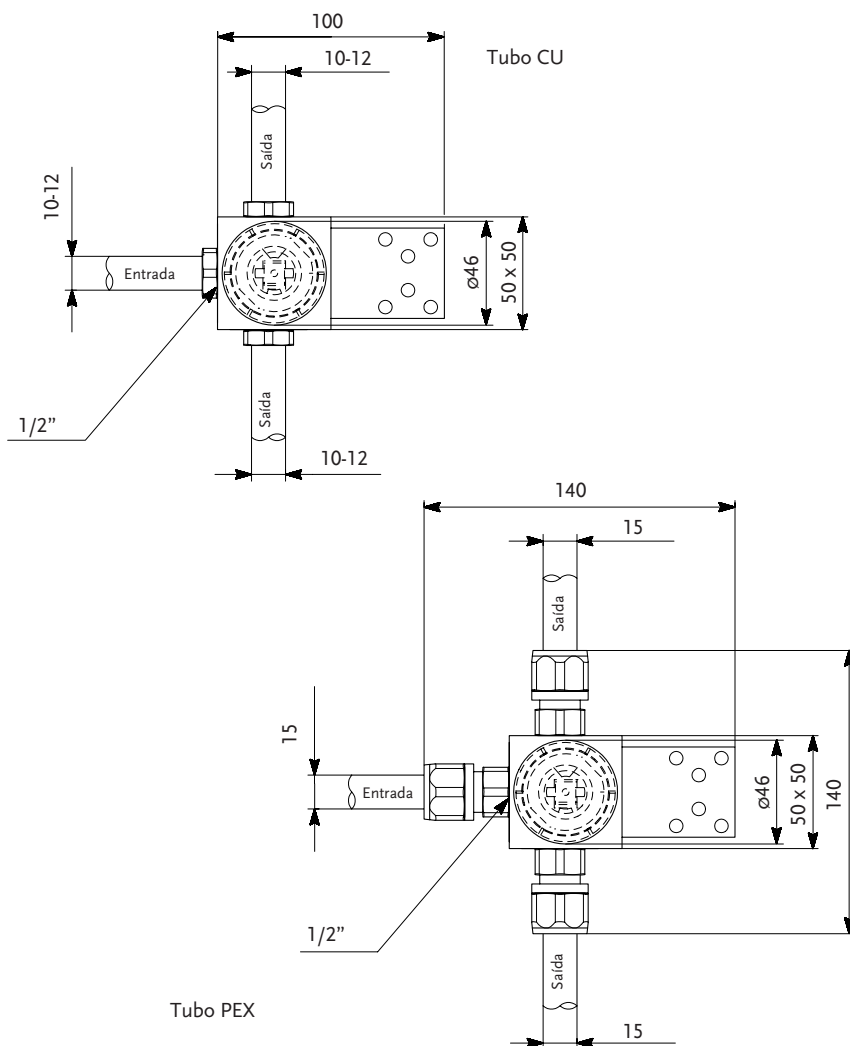

3. Kits de extensão

Espessura standard do revestimento de parede = 3 - 13 mm.

No caso de um revestimento de parede mais grosso, poderão ser fornecidos kits de extensão (ver tabela a seguir):

Espessura do azulejo (x)	Dimensão da extremidade do fuso à superfície exterior da parede (y)	Tipo de misturadora	
		F1344	
		F1152	
		F1629	
		F1155	
3 - 13 mm	44 - 54 mm	Standard	
13 - 23 mm	34 - 44 mm	F960122NU	
23 - 33 mm	24 - 34 mm	F960123NU	
33 - 43 mm	14 - 24 mm	F960124NU	
43 - 53 mm	4 - 14 mm	F960125NU	

4. Instruções para montagem de misturadoras ocultas em paredes finas (18 mm ou 2 x 13 mm)

Recorte, parede fina - 18 mm
 Recorte, parede fina - 2 x 13 mm

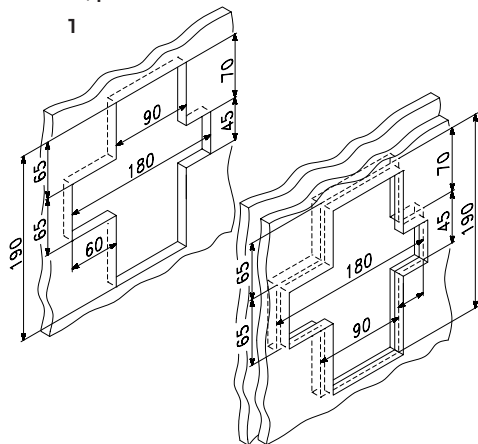

Camada - 1ª vez sob membrana de borracha

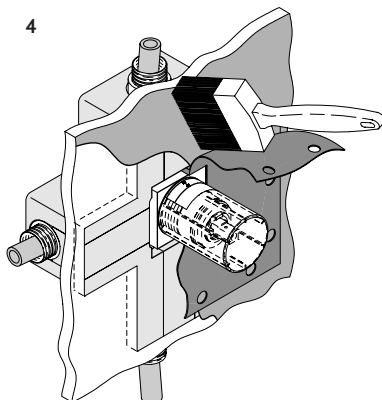

Ligação de 1/2" para tubos de cobre, tubos de plástico ou tubos de aço e montagem de caixa de estireno

Camada - 2ª vez sobre membrana de borracha

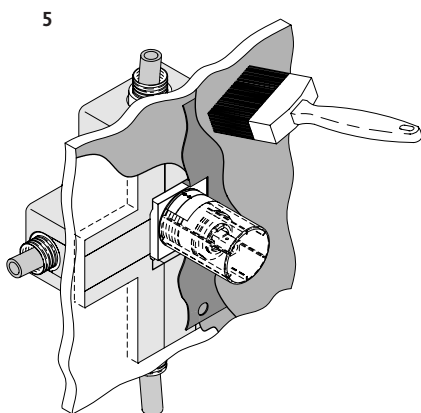
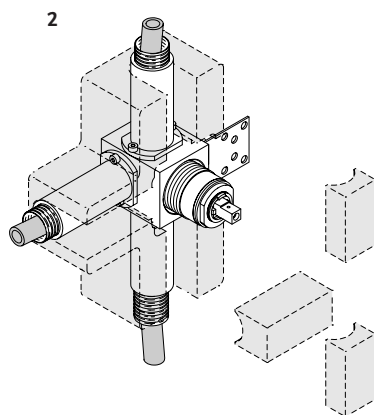

Tapar com membrana

Revestimento de parede, por exemplo, azulejos

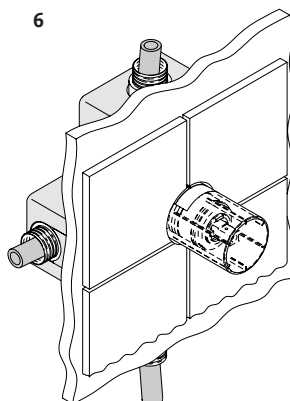
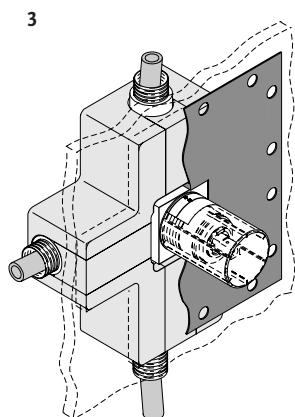

5. Instruções para montagem de misturadoras ocultas em paredes de tijolo

Recorte, construção de tijolo

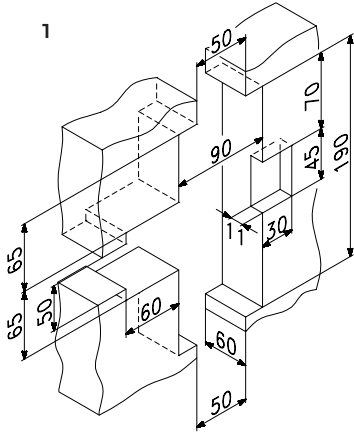

Camada - 1ª vez sob membrana de borracha

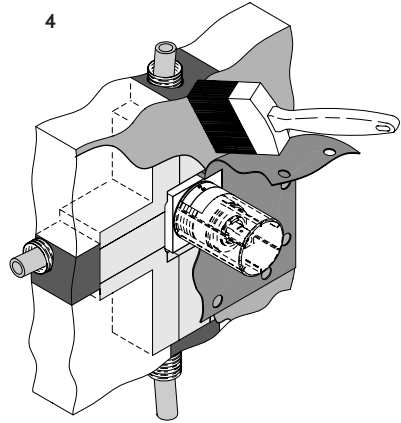

Ligação de 1/2" para tubos de cobre, tubos de plástico (tubo PEX) ou tubos de aço

2

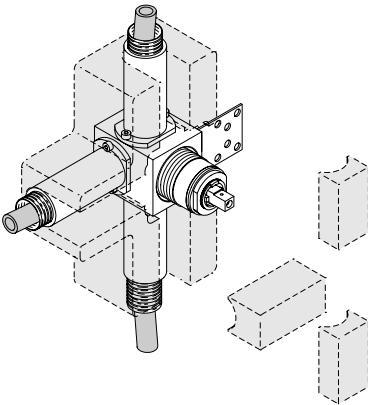

Camada - 2ª vez sobre membrana de borracha

5

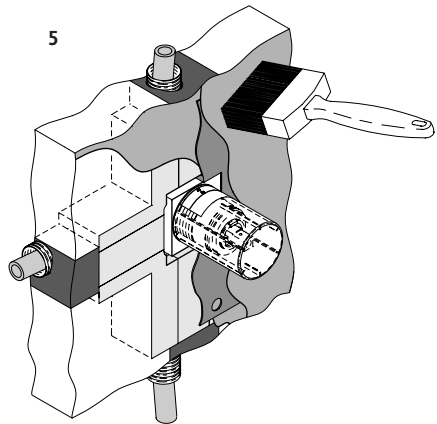

Tapar

3

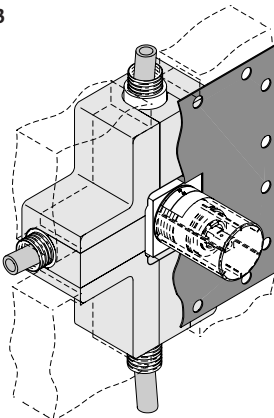

Revestimento de parede, por exemplo, azulejos

6

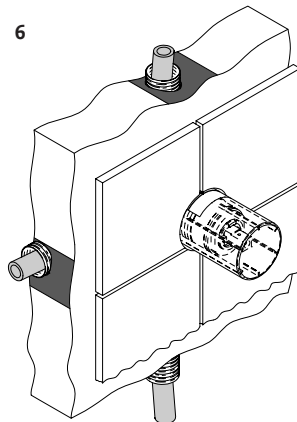

6. Montagem final

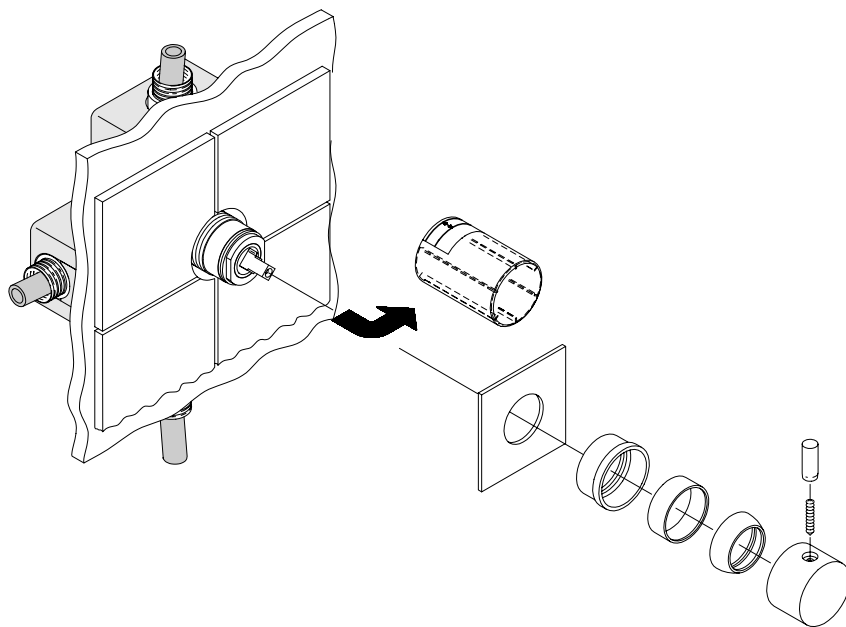

7. Vista em destaque dos componentes

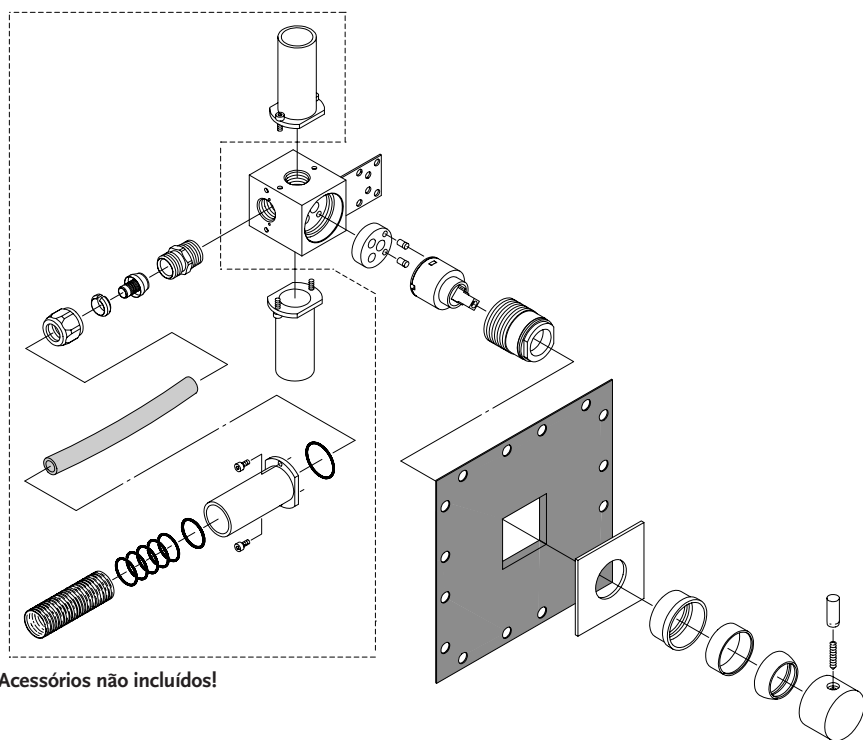

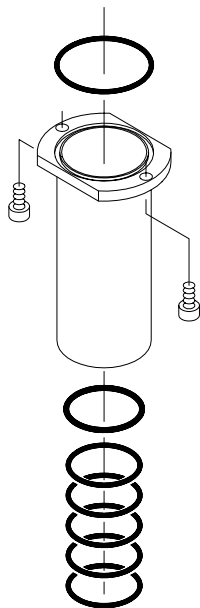

Acessório para tubo corrugado

N.º de conjuntos de tampas necessários		Artigo n.º
2 x	F960747NU	F1344 F1152 F1629 F1155

O kit de acessórios acima mencionado é adequado para todas as ligações de um determinado modelo. Exemplo: o kit de acessórios F960747NU, por exemplo, F1344 inclui todas as ligações necessárias.

1. Mengkranen reinigen

Voordat ze de fabriek verlaten worden alle kranen stuk voor stuk gecontroleerd op hun goede werking en de afwezigheid van beschadigingen. Zo houdt u het oppervlak van de kraan in goede conditie:

Chromen oppervlakken

en gepolijste koperen oppervlakken reinigt u met een zachte doek en zeepsop of een vloeibaar, zuurrij reinigingsproduct zonder schuurmiddel.

Kalkresten

verwijdt u met gewone huishoudazijn.

Gekleurde emailoppervlakken

verliezen hun glans als ze worden gereinigd met producten die schuurmiddelen bevatten. Gebruik alleen schoon water of verdunde reinigingsmiddelen. Kalkresten verwijdert u met gewone huishoudazijn.

Beluchters

Kalk in beluchters: Week de beluchter in huishoudazijn totdat de kalk is opgelost.

2. Afmetingen

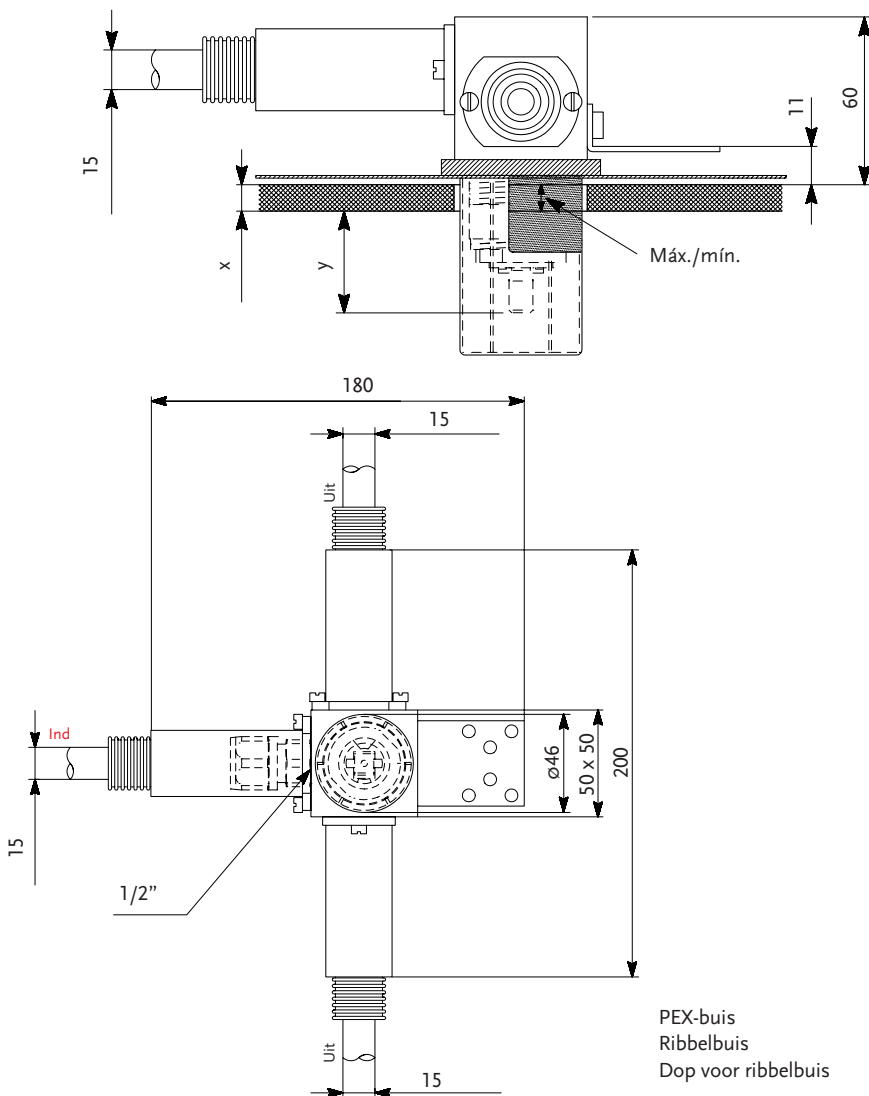

2. Afmetingen

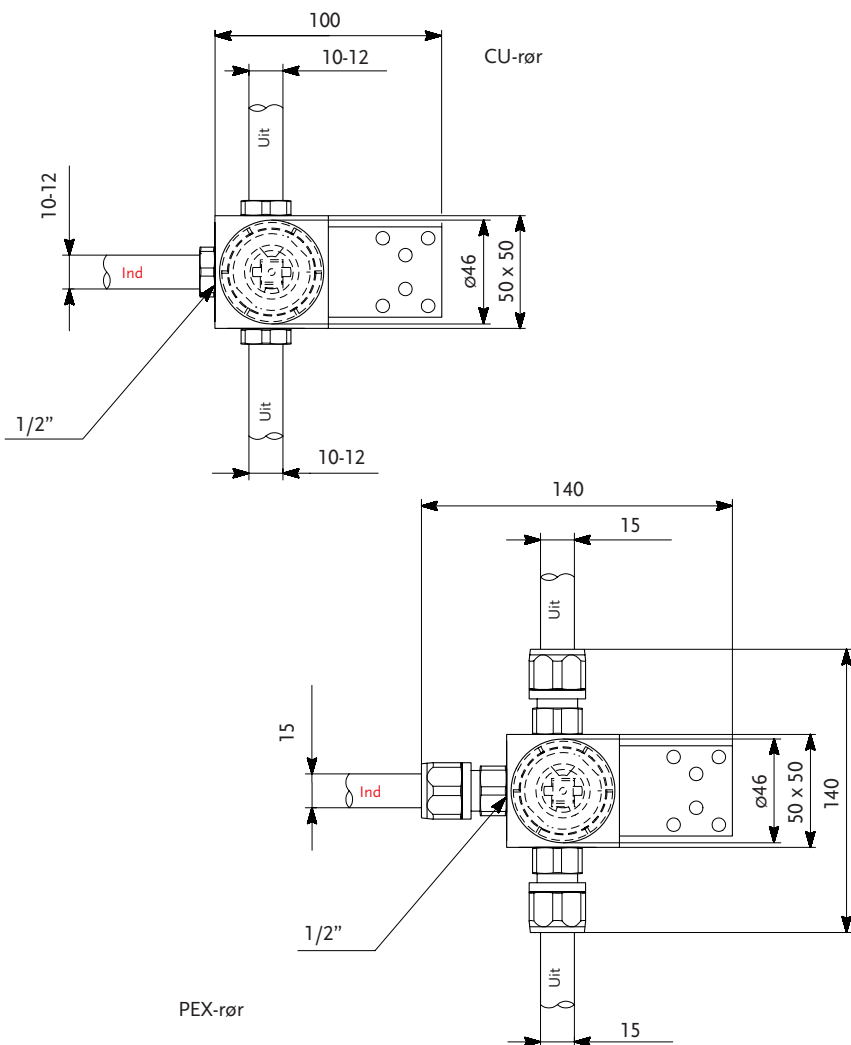

3. Verlengsets

Standaarddikte wandbekleding = 3 - 13 mm.

Voor dickere wandbekledingen kan de spil worden verlengd (zie onderstaande tabel):

Tegeldikte (x)	Afmeting van spileind tot buitenoppervlak wand (y)	Type mengkraan	
		F1344	F1152
3 - 13 mm	44 - 54 mm	Standard	
13 - 23 mm	34 - 44 mm	F960122NU	
23 - 33 mm	24 - 34 mm	F960123NU	
33 - 43 mm	14 - 24 mm	F960124NU	
43 - 53 mm	4 - 14 mm	F960125NU	

4. Richtlijnen voor montage van inbouwmengkranen in lichtgewicht wanden (18 mm of 2 x 13 mm)

Uitsparing, lichtgewicht wand - 18 mm
 Uitsparing, lichtgewicht wand - 2 x 13 mm

Coating - 1^e maal onder rubber membraan

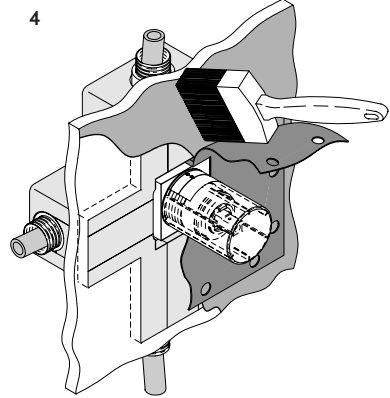
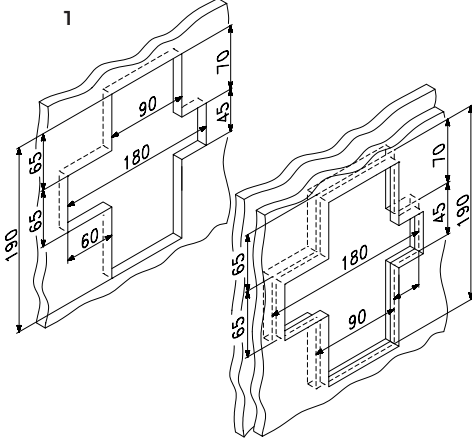

1/2" aansluiting voor koperen, plastic of stalen leidingen en montage van styreendoos

Coating - 2^e maal over rubber membraan heen

2

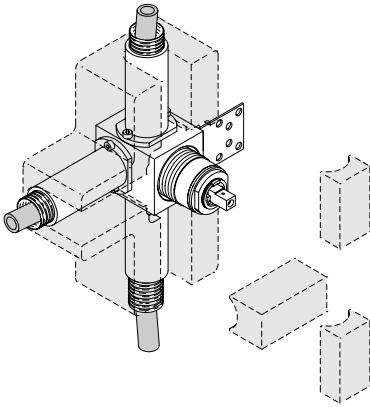

5

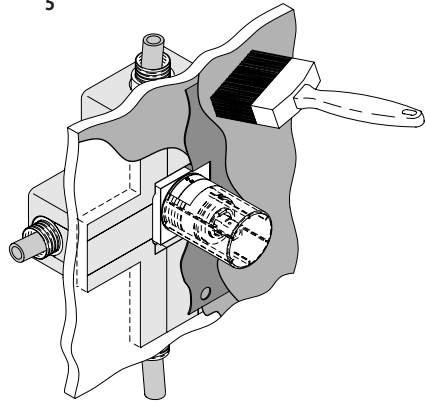

Dichtmaken met membraan

Wandbekleding, bijv. tegelwerk

3

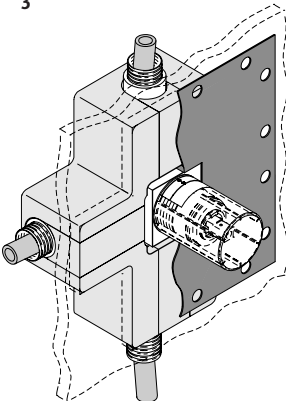

6

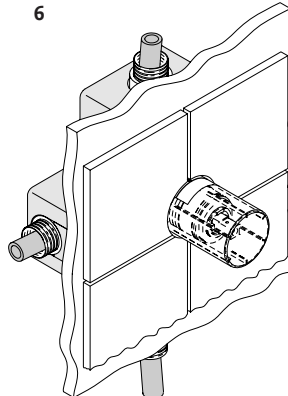

5. Richtlijnen voor montage van inbouwmengkranen in gemetselde muren

Uitsparing, metselwerk

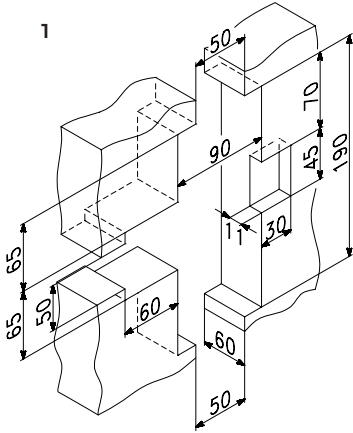

Coating - 1^e maal onder rubber membraan

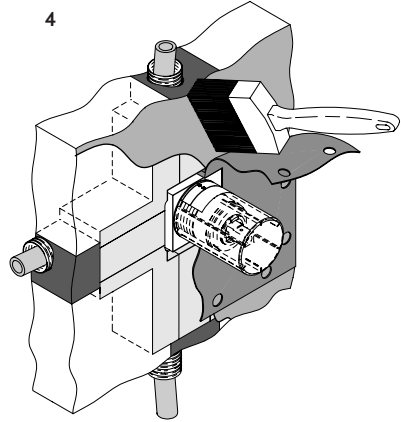

1/2" aansluiting voor koperen, plastic (PEX) of stalen leidingen

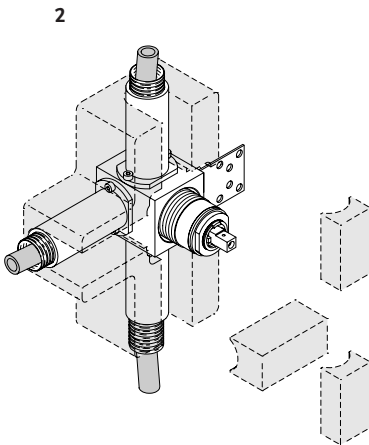

Coating - 2^e maal over rubber membraan heen

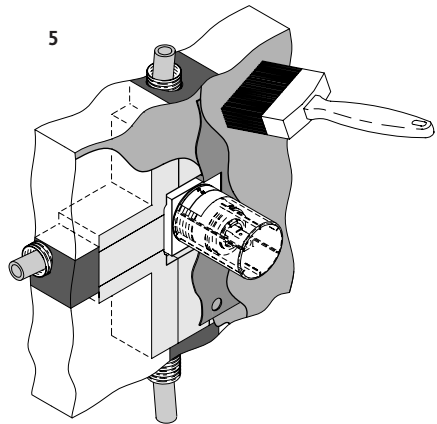

Dichtmaken met membraan

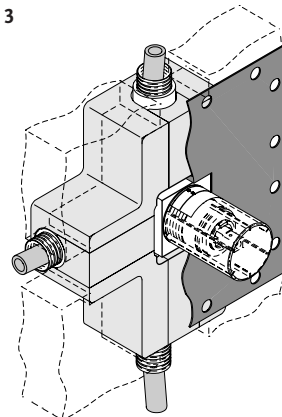

Wandbekleding, bijv. tegelwerk

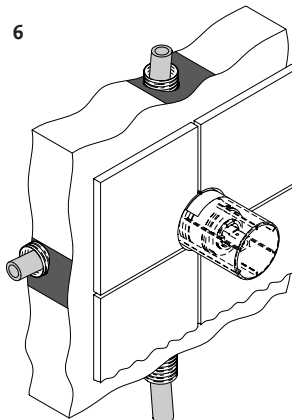

6. Eindmontage

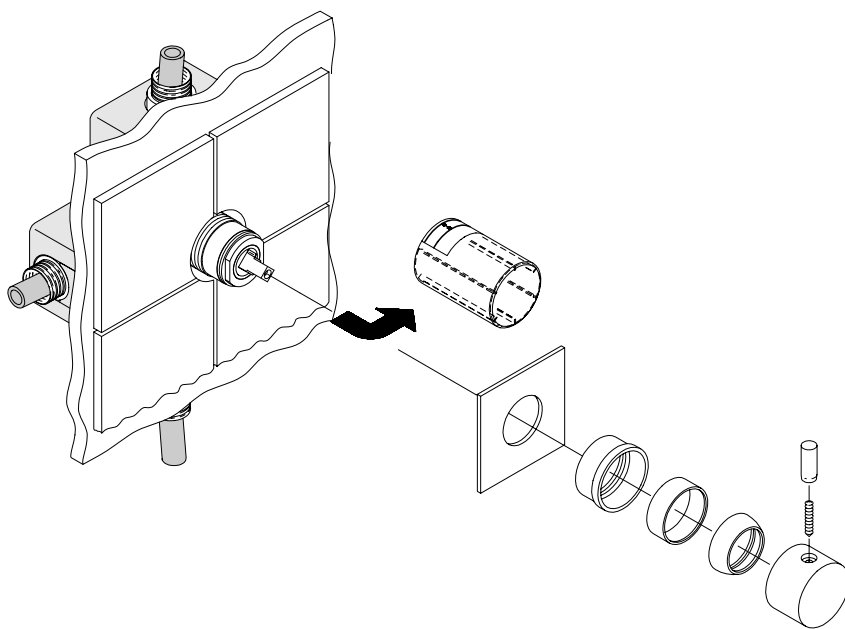

7. Opengewerkte tekening

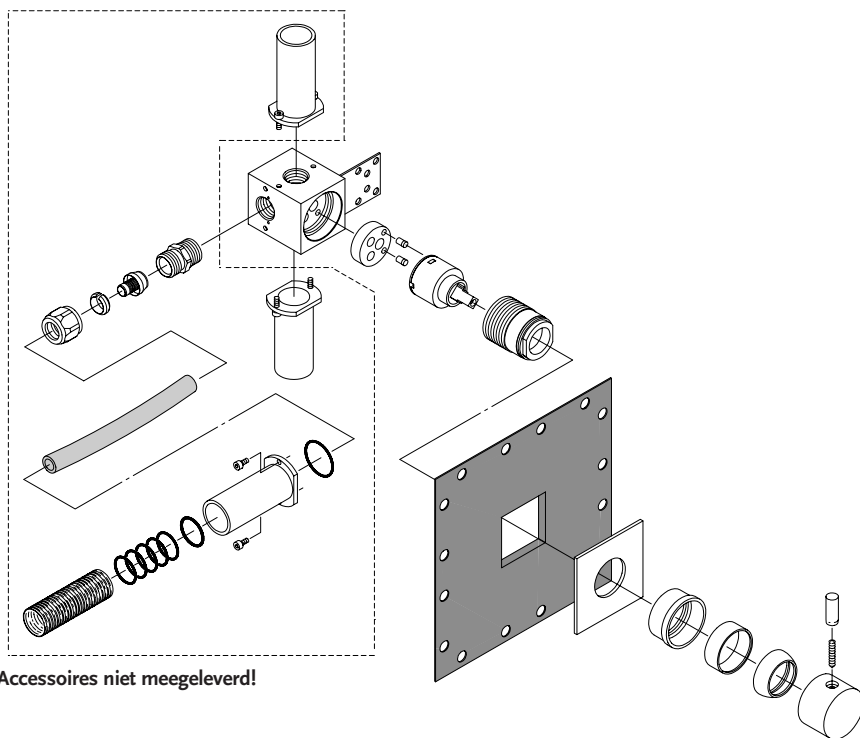

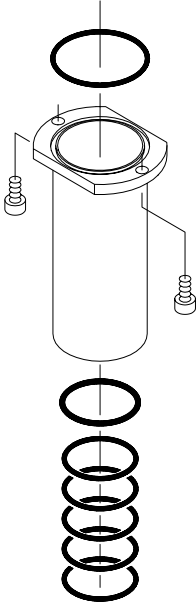

Accessoireset voor ribbelbuis

Aantal benodigde dopsets		Artikelnr.
2 x	F960747NU	F1344 F1152 F1629 F1155

Bovenstaande accessoireset is geschikt voor alle aansluitingen van een gegeven model.
 Voorbeeld: De accessoireset F960747NU voor bijv. F1344 bevat alle benodigde verbindingen.







United Kingdom

Ideal Standard National Avenue Hull England HU5 4HS
TEL.: 01482 499685

Germany

pro-Service Euskirchener Straße 80 D-63322 Rödemark
Tel.: +49 (0) 228-521580 Fax: +49 (0) 228-521589
www.pro-service.info E-mail: pro-service.info@aseur.com

France

Ideal Standard France Bat.H, 165 Av. du Bois de la pie, Paris N2
95920 Roissy CDG Tel.: +43 0149 388 181 www.idealstandard.fr

Scandinavian

Ideal Standard Scandinavia A/S Tulipvej 1 DK-7100 Vejle
Tel.: +45 75 84 10 10 Fax: +45 75 84 10 24 www.borma.dk

Nederland

Ideal Standard Nederland L.J.Costerstraat 30 Postbus 7 5900 AA Venlo
Tel.: +31 77 355 08 07

Italiano

Ideal Standard Divisione di American Standard italia S.r.l.
Via Domodosola, 19 20145 Milano Tel.: +39 800 652290

Espaniól

Ideal Standard, S.L. Sant marti, s/n
08107 Martorelles (Barcelona) Tel. General +34 93 5 44 01 60

Portogal

Ideal Standard Portogal Nogueira - Ap. 4 4711 - 909 Braga
08107 Martorelles (Barcelona) Tel.: +253 240001 e-mail: silvaj@aseur.com