



F1335 - F1336 - F1337 - F1338 - F1339 - F1341 - F1342
F1135 - F1136 - F1137 - F1138 - F1139 - F1141 - F1142

Concealed Mixers - Guidelines Page 2

Indbygningsarmatur - Vejledning Side 8

Verdeckte Mischer - Installationshinweise Seite 14

Mitigeurs encastrés - Instructions Page 20

Miscelatori interni - Indicazioni Pag. 26

Mezcladores empotrados - Directrices Página 32

Misturadoras ocultas - Instruções Página 38

Inbouwmengkranen - Richtlijnen Pagina 44

2. Dimensions

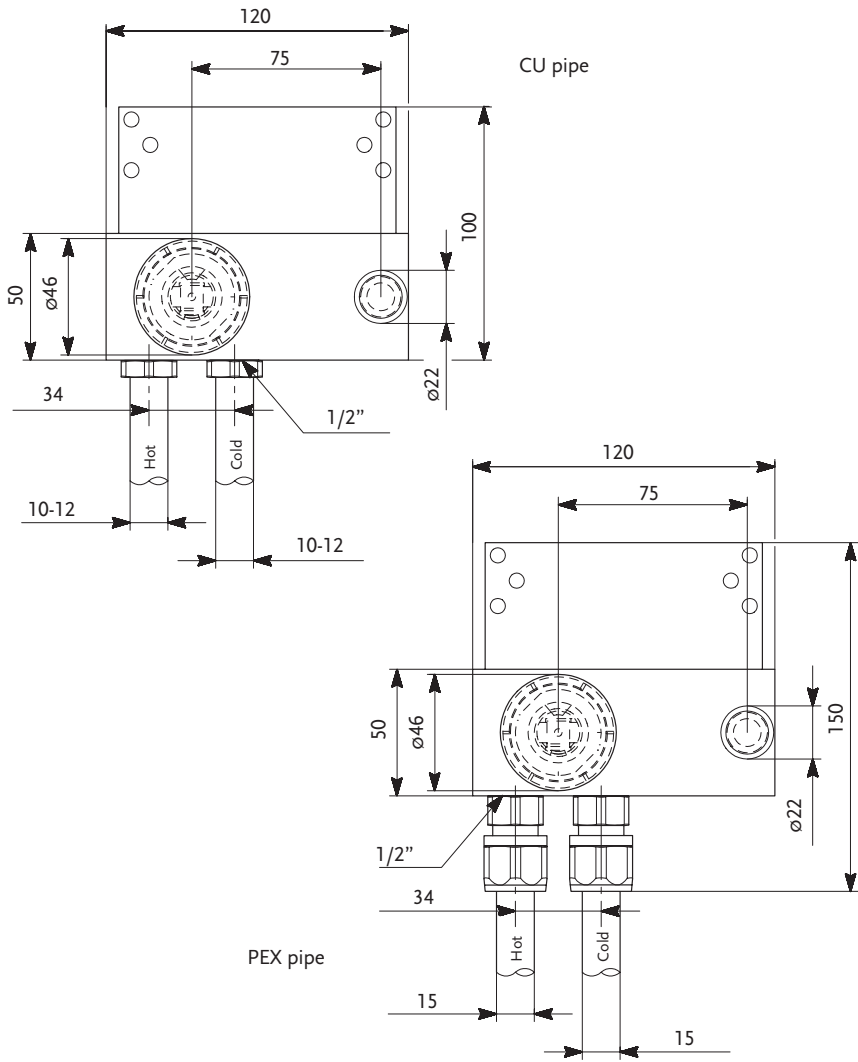

3. Extension kits

Standard thickness of wall covering = 3 - 13 mm.

In case of a thicker wall covering extension kit's can be supplied (see below table):

Tile thickness (x)	Dimension from spindle end to outside surface of wall (y)	Mixer type				
		F1335 F1135 F1341 F1141	F1342 F1142 F1336/F1339 F1136/F1139	F1337 F1137 F1338 F1138		
3 - 13 mm	44 - 54 mm	Standard	Standard	Standard		
13 - 23 mm	34 - 44 mm	F960807NU	F960679NU	F960128NU		
23 - 33 mm	24 - 34 mm	F960260NU	F960049NU	F960129NU		
33 - 43 mm	14 - 24 mm	F960262NU	F960452NU	F960130NU		
43 - 53 mm	4 - 14 mm	F960263NU	F960615NU	F960131NU		

4. Guidelines for mounting of concealed mixers in lightweight wall (18 mm or 2 x 13 mm)

Cut-out, lightweight wall - 18 mm
 Cut-out, lightweight wall - 2 x 13 mm

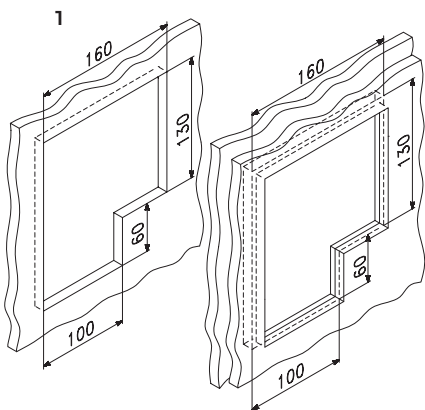

Coating - 1st time under rubber membrane

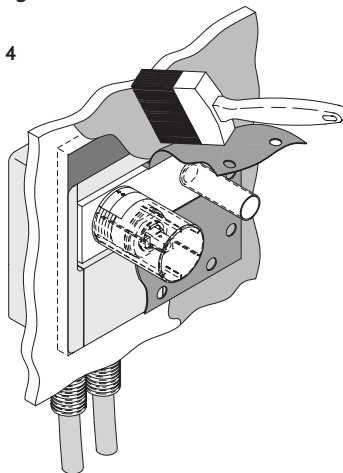

1/2" connection for copper tubes, plastic tubes,
 or steel tubes and assembly of styrenebox

Coating - 2nd time over rubber membrane

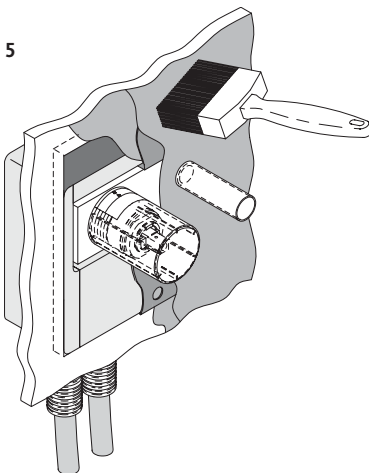
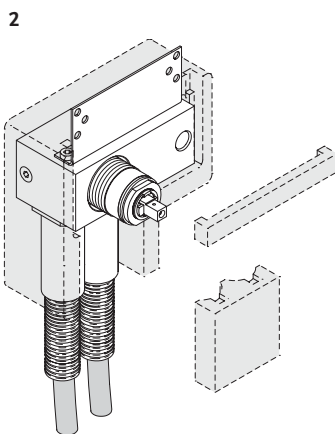

Walling up with membrane

Wall covering, e.g. tiling

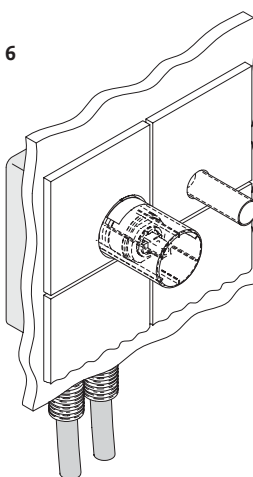
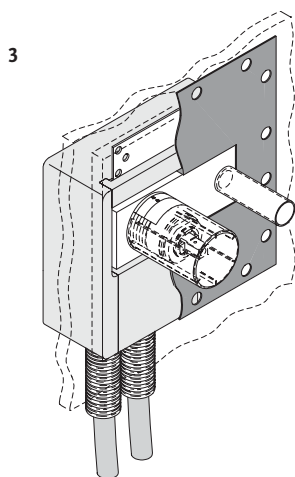

5. Guidelines for mounting of concealed mixers in brick wall

Cut-out, brickwork

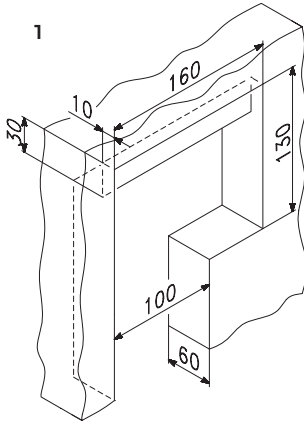

Coating - 1st time under rubber membrane

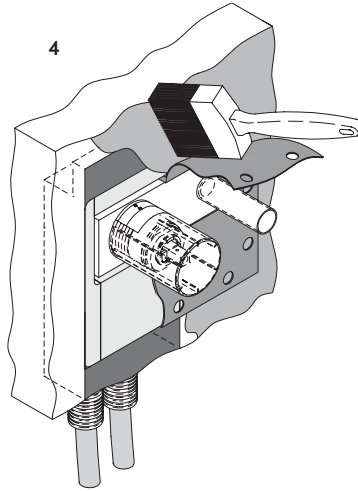

1/2" connection for copper tubes, plastic tubes (PEX pipe), or steel tubes

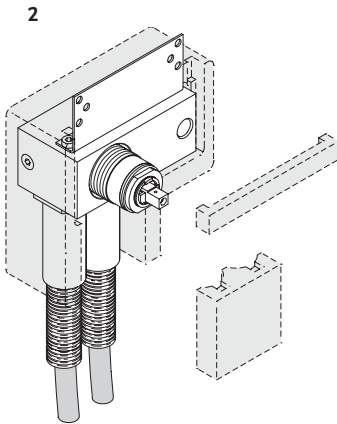

Coating - 2nd time over rubber membrane

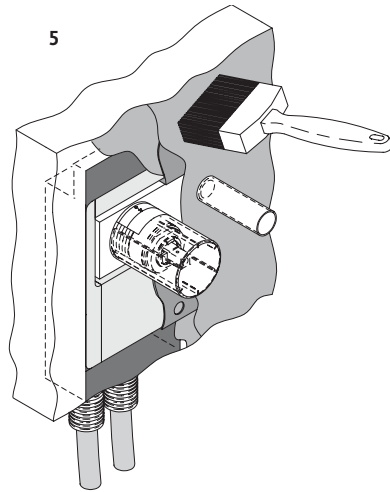

Walling up with membrane

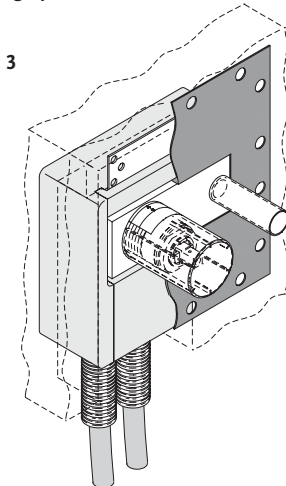

Wall covering, e.g. tiling

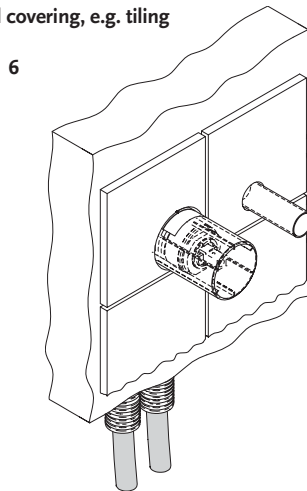

6. Final assembly

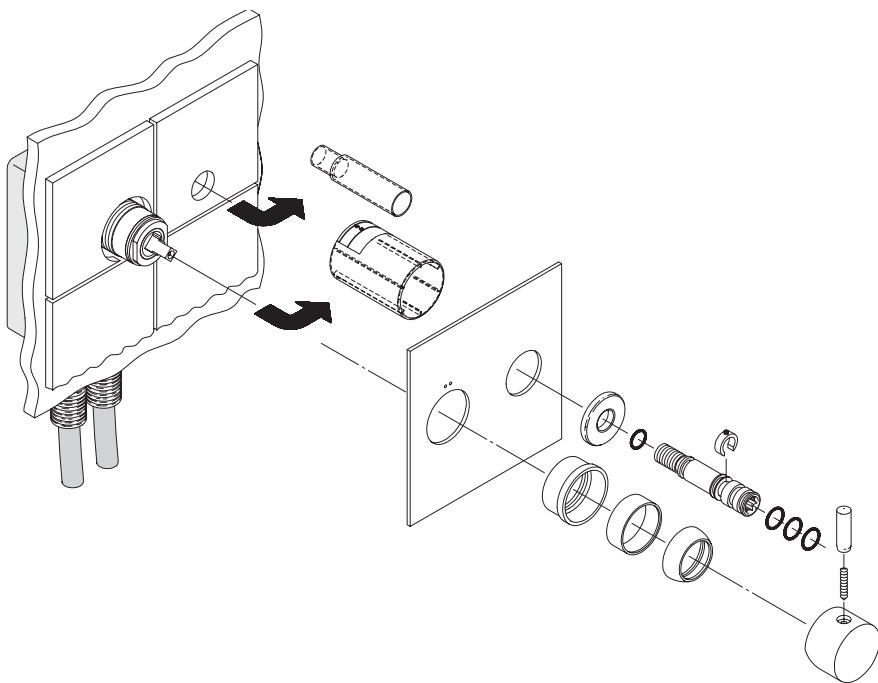

7. Exploded view

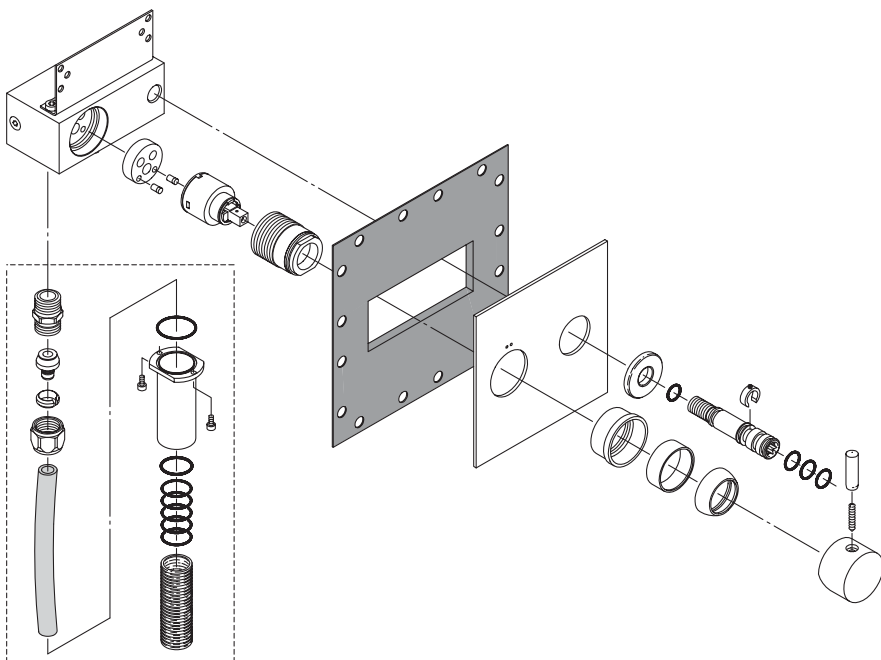

Accessories not included!

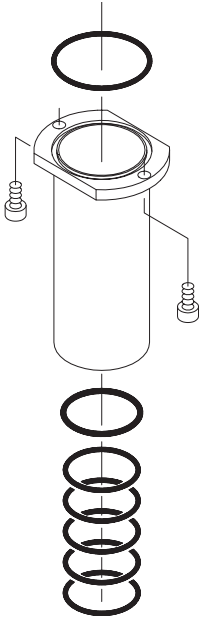

Accessorie for corrugated pipe

No. of cap sets needed		Article No.
		F1335/F1135
		F1336/F1136
		F1337/F1137
1 x	F960747NU	F1338/F1138
		F1339/F1139
		F1341/F1141
		F1342/F1142

Above-mentioned accessory kit is suitable for all connections of a given model.

Example: 1 x accessory kit F960747NU for e.g. F1335 includes all necessary connections.

1. Rengøring af blandingsbatterier

Hvert blandingsbatteris overflade og funktion efteres og kontrolleres enkeltvis, før de forlader fabrikken.

Følg nedenstående vejledning for at beskytte og bevare overfladen:

Kromoverflader

samt polerede messingoverflader rengøres med en blød klud og væske, syrefri rengøringsmiddel uden slibemiddel eller med sæbevand.

Kalkaflejringer

kan fjernes med almindelig husholdningseddike.

Farvede lakoverflader

mister deres skinnende udseende, hvis de rengøres med midler, der indeholder slibemiddel. Brug kun rent vand eller fortyndet rengøringsmiddel. Kalkaflejringer kan fjernes med almindelig husholdningseddike.

Luftblander

Kalk i luftblander: Anbring luftblanderen i husholdningseddike, og lad den ligge i blød, indtil kalken er opløst.

2. Mål

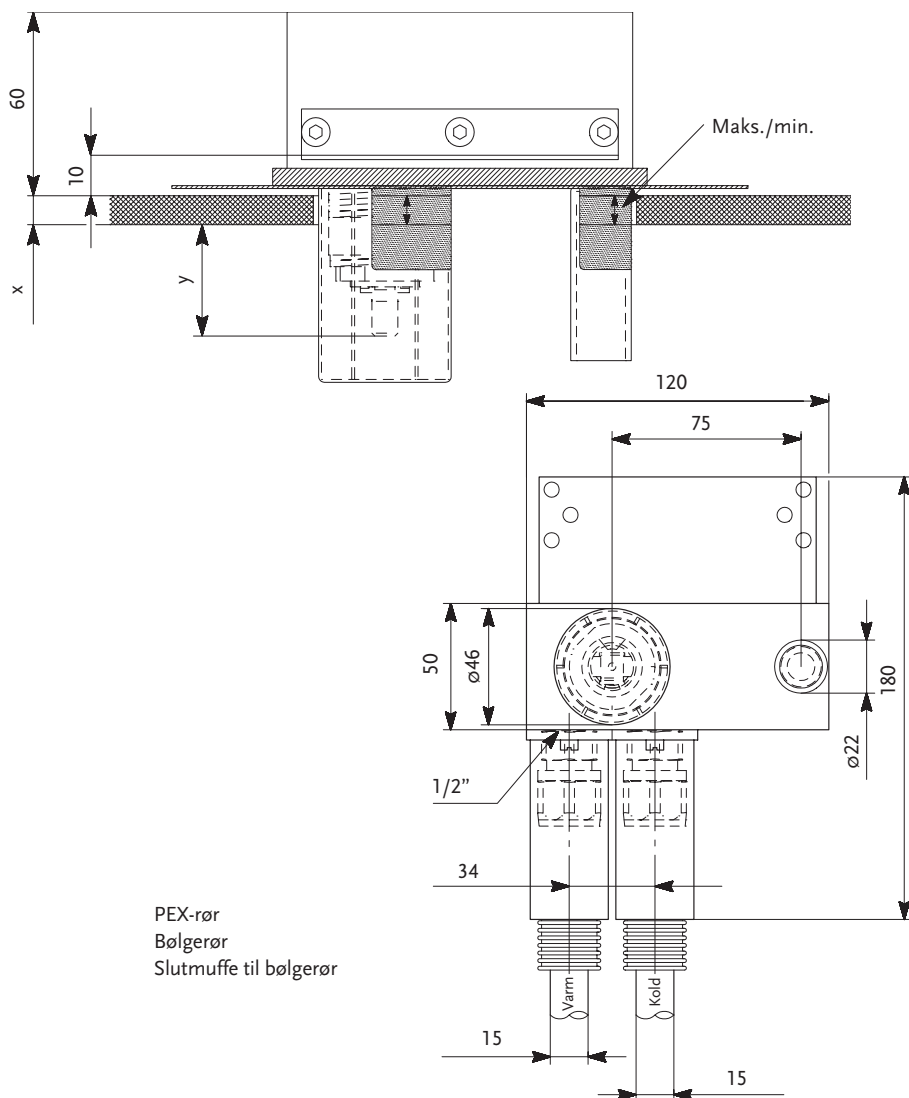

2. Mål

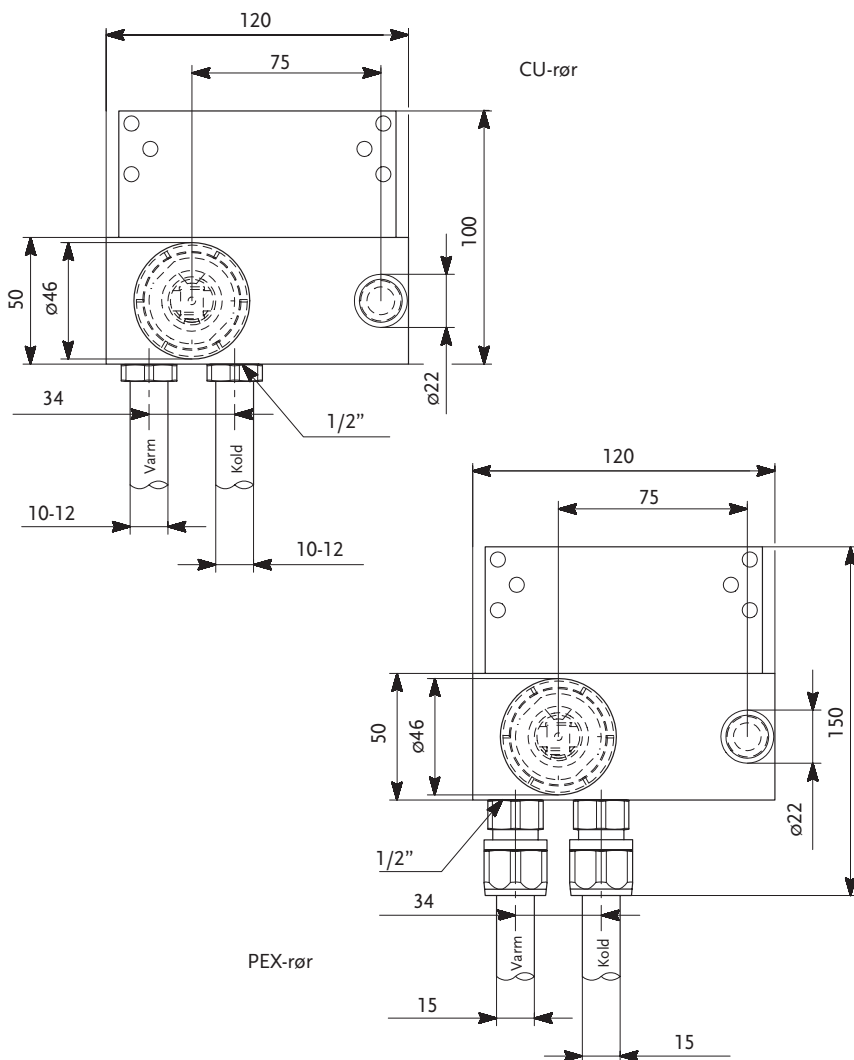

3. Forlængersæt

Vægbeklædningens standardtykkelse = 3 - 13 mm. I tilfælde af tykkere vægbeklædning kan forlængersæt leveres (se nedenstående tabel):

Flisetykkelse (x)	Mål fra spindelenden til væggen overflade på ydersiden (y)	Blandingsbatteri - type				
		F1335 F1135 F1341 F1141	F1342 F1142 F1336/F1339 F1136/F1139	F1337 F1137 F1338 F1138		
3 - 13 mm	44 - 54 mm	Standard	Standard	Standard		
13 - 23 mm	34 - 44 mm	F960807NU	F960679NU	F960128NU		
23 - 33 mm	24 - 34 mm	F960260NU	F960049NU	F960129NU		
33 - 43 mm	14 - 24 mm	F960262NU	F960452NU	F960130NU		
43 - 53 mm	4 - 14 mm	F960263NU	F960615NU	F960131NU		

4. Vejledning til montering af skjulte blandingsbatterier i letvægtsvæg (18 mm eller 2 x 13 mm)

Udskæring, letvægtsvæg - 18 mm

Udskæring, letvægtsvæg - 2 x 13 mm

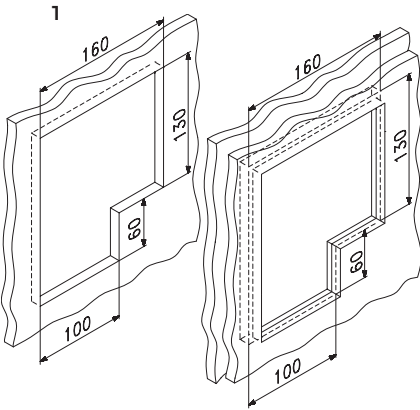

1/2" tilslutning til kobberrør, plasticrør eller stålør og samling af styrendåse

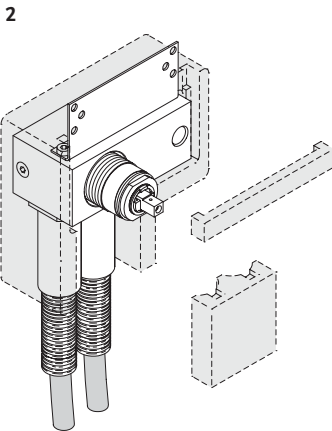

Tilmuring med membran

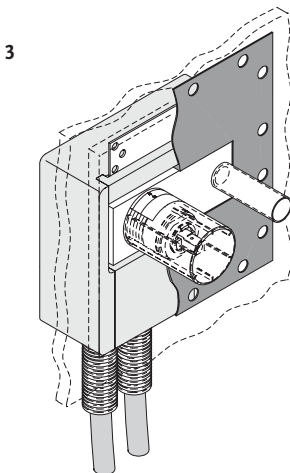

Bestrygning - 1. gang under gummimembranen

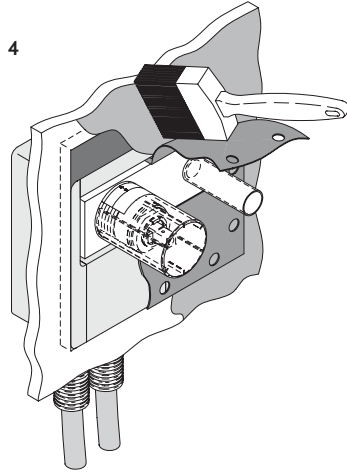

Bestrygning - 2. gang over gummimembranen

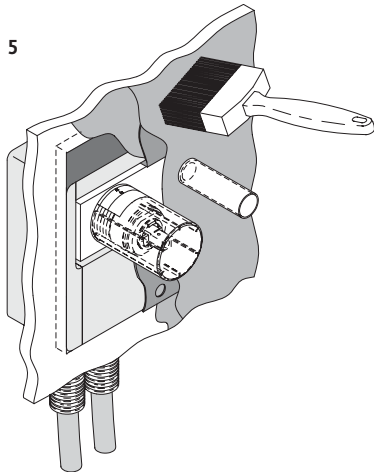

Vægbelægning, f.eks. fliser

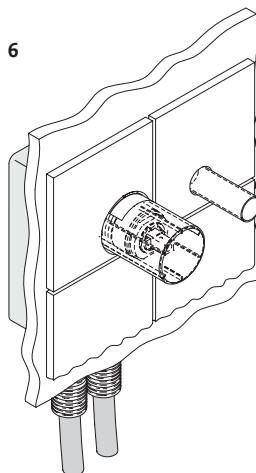

5. Vejledning til montering af skjulte blandingsbatterier i murstensvæg

Udskæring, murværk

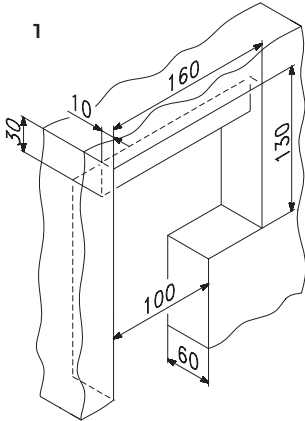

Bestrygning - 1. gang under gummimembranen

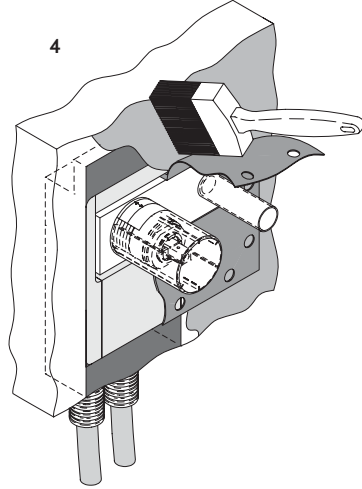

1/2" tilslutning til kobberrør, plasticrør (PEX-rør) eller stålør

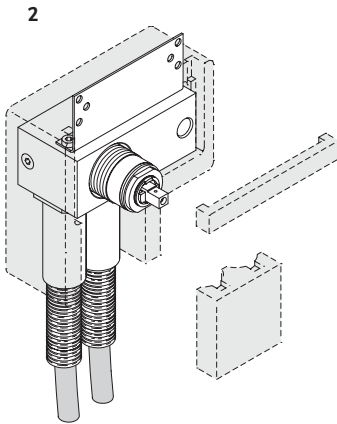

Bestrygning - 2. gang over gummimembranen

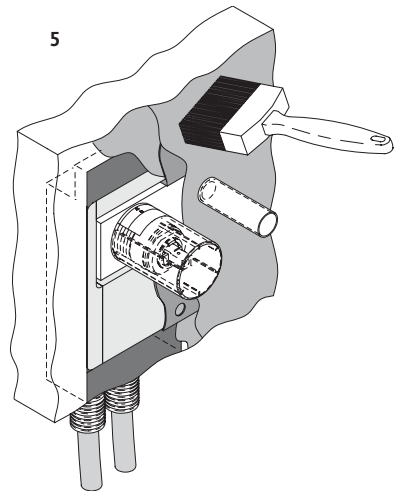

Tilmuring med membran

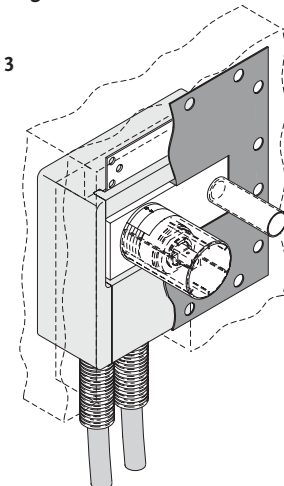

Vægbeklædning, f.eks. fliser

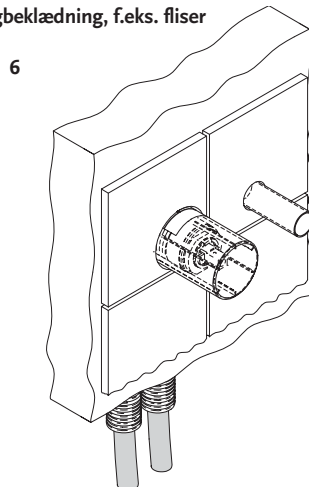

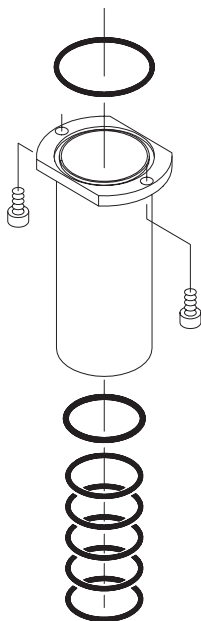

Tilbehør til bølgerør

Antal nødvendige slutmuffer		Artikel nr.
		F1335/F1135 F1336/F1136 F1337/F1137
1 x	F960747NU	F1338/F1138 F1339/F1139 F1341/F1141 F1342/F1142

Ovennævnte tilbehørssæt er egnet til alle tilslutninger af en given model.

Eksempel: 1 x tilbehørssættet F960747NU til f.eks. F1335 indeholder alle nødvendige tilslutninger.

1. Reinigung der Mischer

Oberfläche und Funktion jedes einzelnen Mischers wurden vor der Auslieferung ab werk durchgeprüft.

Zum Schutz der Oberfläche beachten Sie bitte die folgenden Hinweise:

Chromoberflächen

und polierte Messingoberflächen müssen mit einem weichen Tuch und säurefreien Flüssigreinigern ohne Scheuermittel bzw. mit einer Seifenlauge gesäubert werden.

Kalkrückstände

können mit handelsüblichem Essig entfernt werden.

Farbige Emailoberflächen

verlieren ihren Glanz, wenn sie mit scheuernden Reinigern gesäubert werden. Benutzen Sie nur reines Wasser oder verdünntes Reinigungsmittel. Kalkrückstände können mit handelsüblichem Essig entfernt werden.

Belüfter

Kalk in Belüftern: Weichen Sie den Belüfter in handelsüblichem Essig ein, bis sich der Kalk löst.

2. Maße

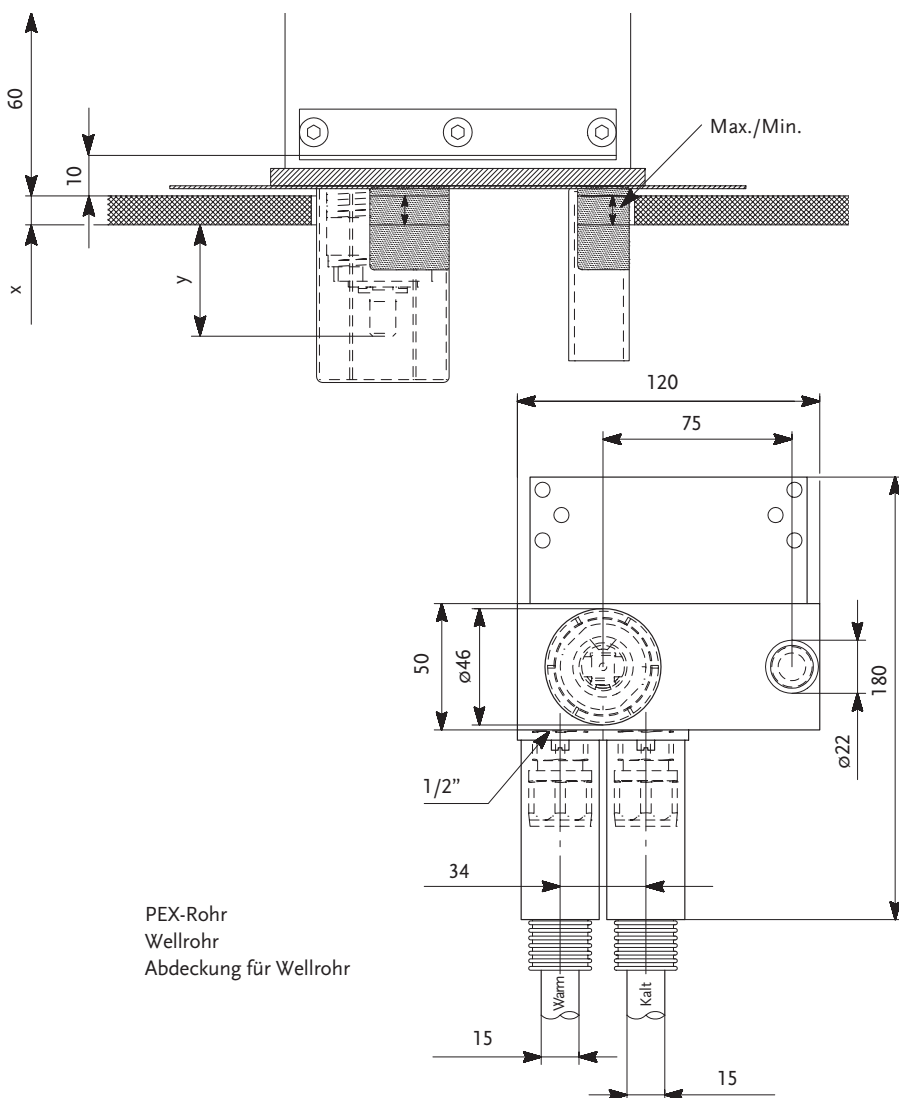

2. Maße

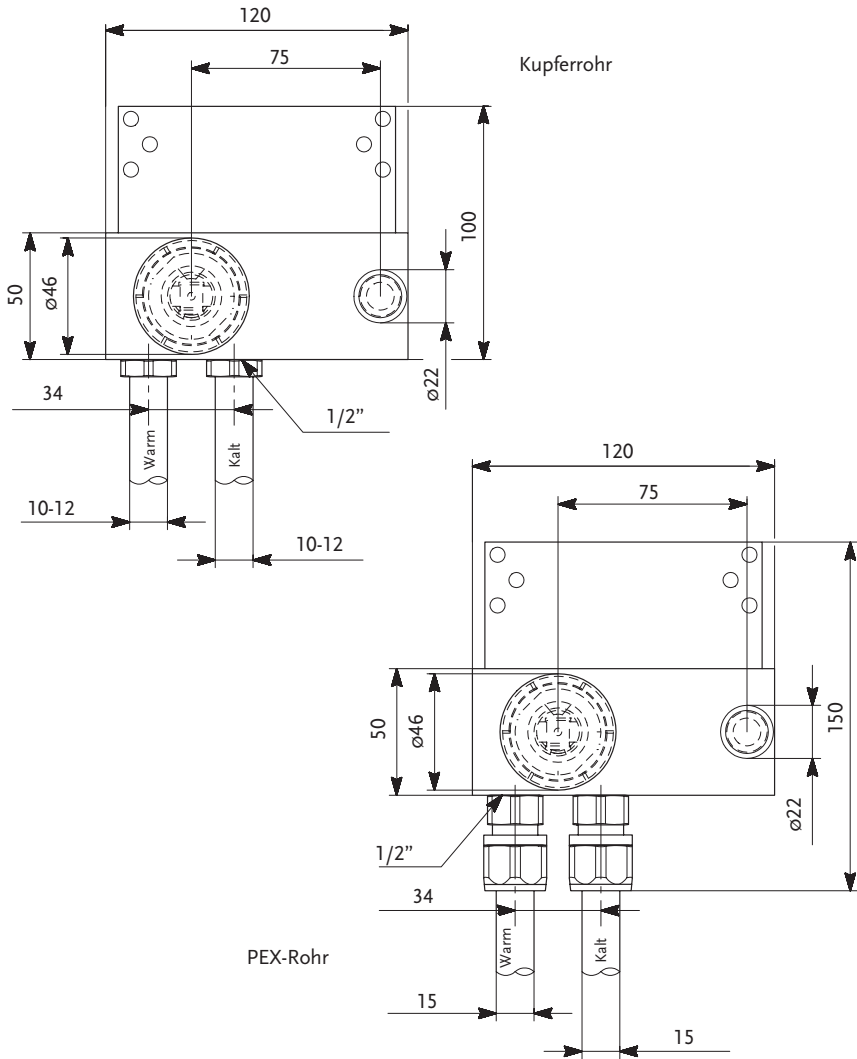

3. Verlängerungssätze

Standardstärke der Wandbedeckung = 3 - 13 mm.

Für stärkere Wandbedeckungen sind Verlängerungssätze lieferbar (siehe nachstehende Tabelle):

Fliesenstärke (x)	Maß von Spindelende zu äußerer Wand- oberfläche (y)	Mischertyp					
		F1335 F1135 F1341 F1141	F1342 F1142 F1336/F1339 F1136/F1139	F1337 F1137 F1338 F1138			
3 - 13 mm	44 - 54 mm	Standard	Standard	Standard			
13 - 23 mm	34 - 44 mm	F960807NU	F960679NU	F960128NU			
23 - 33 mm	24 - 34 mm	F960260NU	F960049NU	F960129NU			
33 - 43 mm	14 - 24 mm	F960262NU	F960452NU	F960130NU			
43 - 53 mm	4 - 14 mm	F960263NU	F960615NU	F960131NU			

4. Installationshinweise für verdeckte Mischer in Leichtbauwänden (18 mm bzw. 2 x 13 mm)

Ausschnitt, Leichtbauwand - 18 mm
 Ausschnitt, Leichtbauwand - 2 x 13 mm

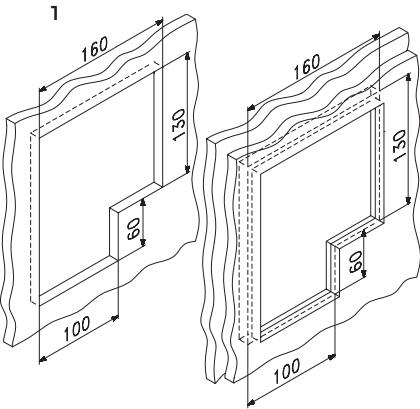

Beschichtung - 1. unter Gummimembrane

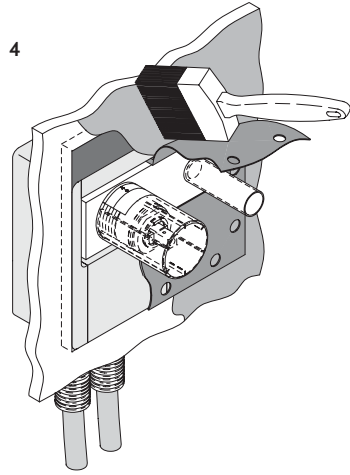

1/2"- Anschluss für Kupfer-, Kunststoff- oder
 Stahlrohre und Styrolbox

Beschichtung - 2. über Gummimembrane

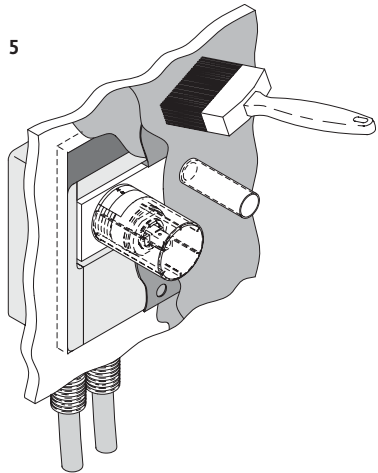
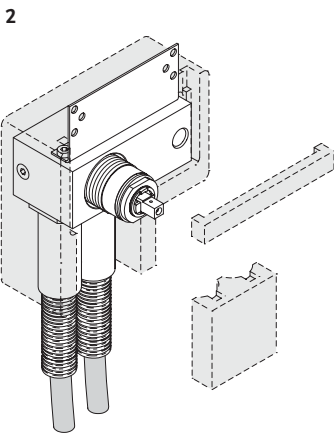

Wandangleichung an Membrane

Wandbedeckung, z.B. Fliesen

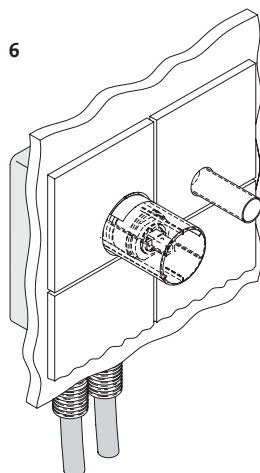
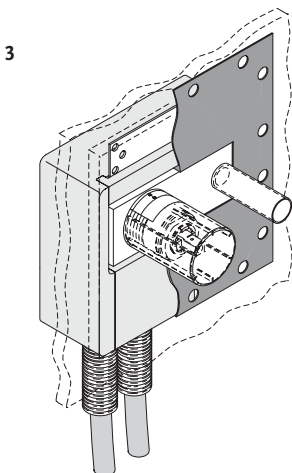

5. Installationshinweise für verdeckte Mischer in gemauerten Wänden

Ausschnitt, Mauerwerk

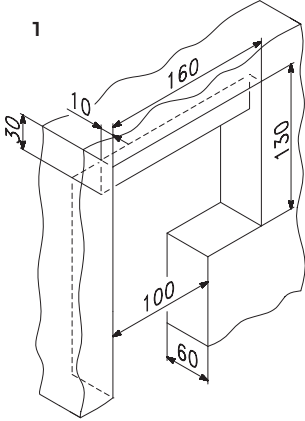

Beschichtung - 1. unter Gummimembrane

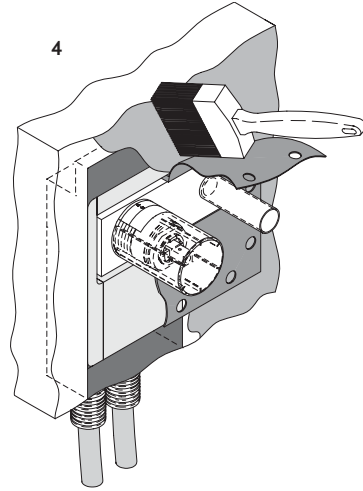

1/2"- Anschluss für Kupfer-, Kunststoff- (PEX-) oder Stahlrohre

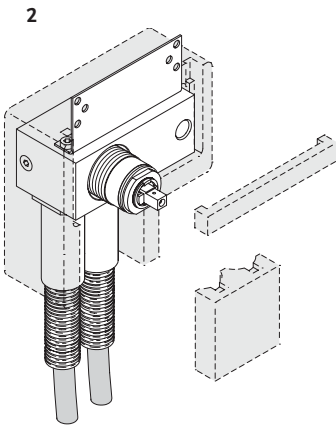

Beschichtung - 2. über Gummimembrane

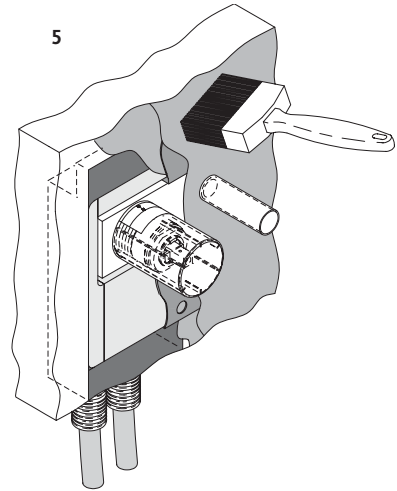

Wandangleichung an Membrane

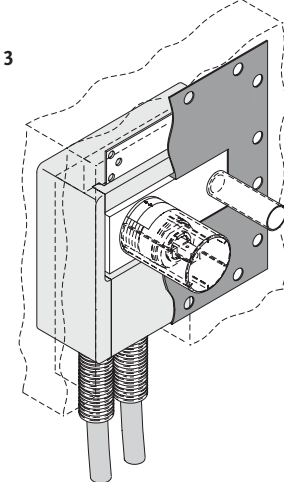

Wandbedeckung, z.B. Fliesen

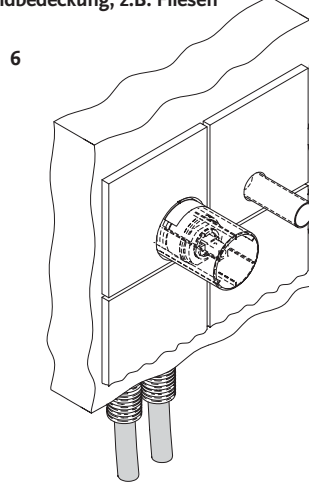

6. Montage

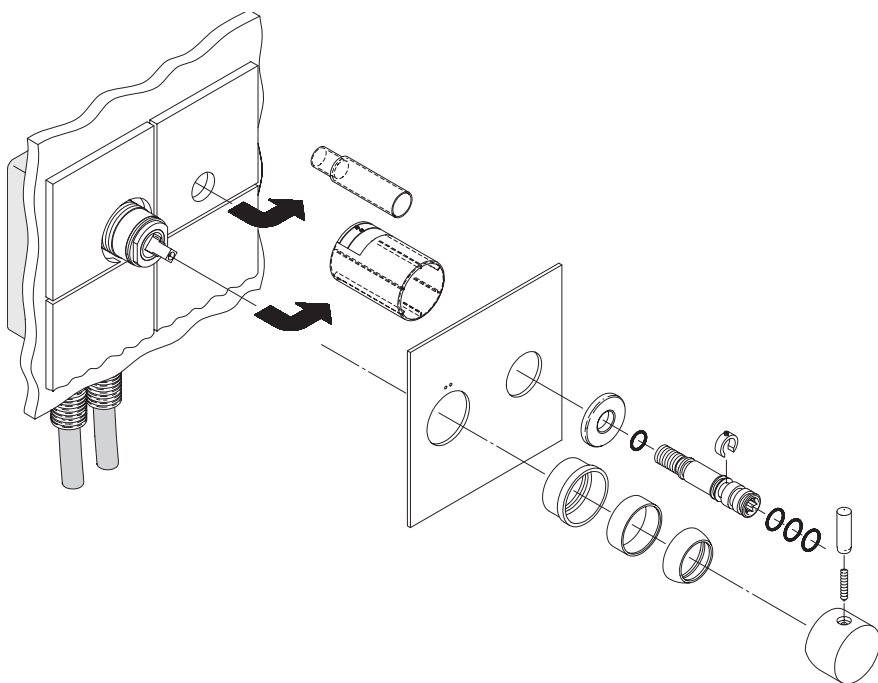

7. Explosionsansicht

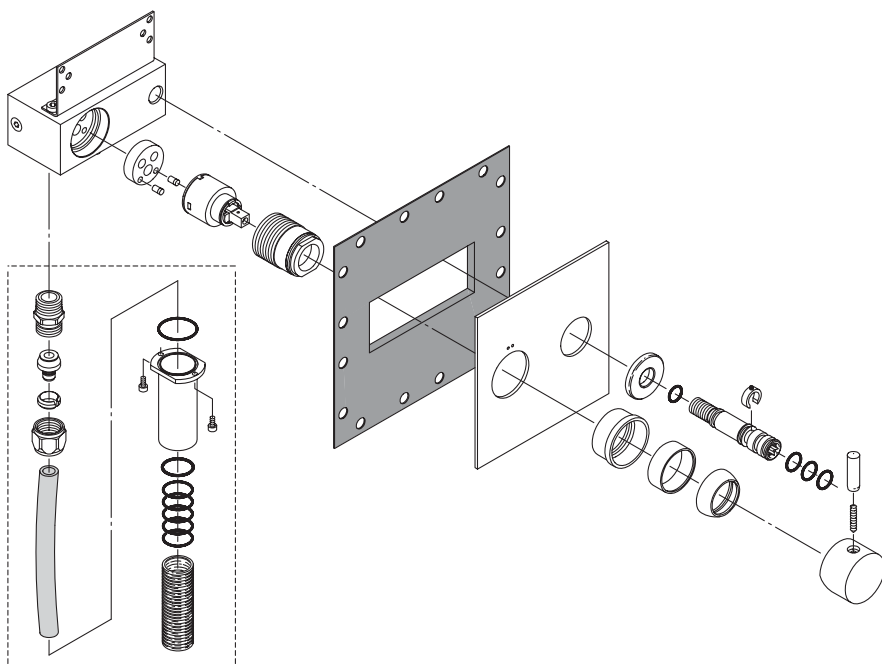

Zubehör nicht im Lieferumfang!

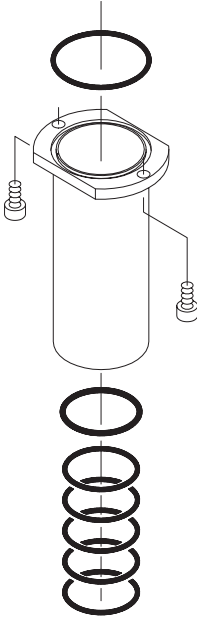

Zubehör für Wellrohr

Anzahl der benötigten Abdeckungssätze		Artikel-Nr.
1 x	F960747NU	F1335/F1135 F1336/F1136 F1337/F1137 F1338/F1138 F1339/F1139 F1341/F1141 F1342/F1142

Der obige Zubehörsatz eignet sich für alle Anschlüsse eines bestimmten Modells.

Beispiel: 1 x Zubehörsatz F960747NU z.B. für F1335 enthält alle notwendigen Anschlüsse.

1. Nettoyage des mitigeurs

La surface et le bon fonctionnement de chaque robinetterie ont été vérifiés et contrôlés individuellement avant de quitter de l'usine.

Afin de protéger et de conserver la surface en bon état, il est nécessaire de suivre les instructions indiquées ci-dessous :

Surfaces chromées

Il convient de nettoyer ces surfaces ainsi que le laiton poli avec un chiffon doux et un détergent liquide non acide et non abrasif ou bien avec de l'eau savonneuse.

Surfaces laquées couleurs

En cas d'utilisation de détergent contenant un abrasif, ces surfaces perdent leur brillance. N'utiliser que de l'eau propre ou du détergent dilué. Retirer les résidus de calcaire à l'aide de vinaigre de ménage.

Aérateurs

Calcaire dans les aérateurs : mettre l'aérateur dans du vinaigre de ménage et le laisser tremper jusqu'à ce que le calcaire soit dissout.

Résidus de calcaire

S'enlèvent à l'aide de vinaigre de ménage.

2. Dimensions

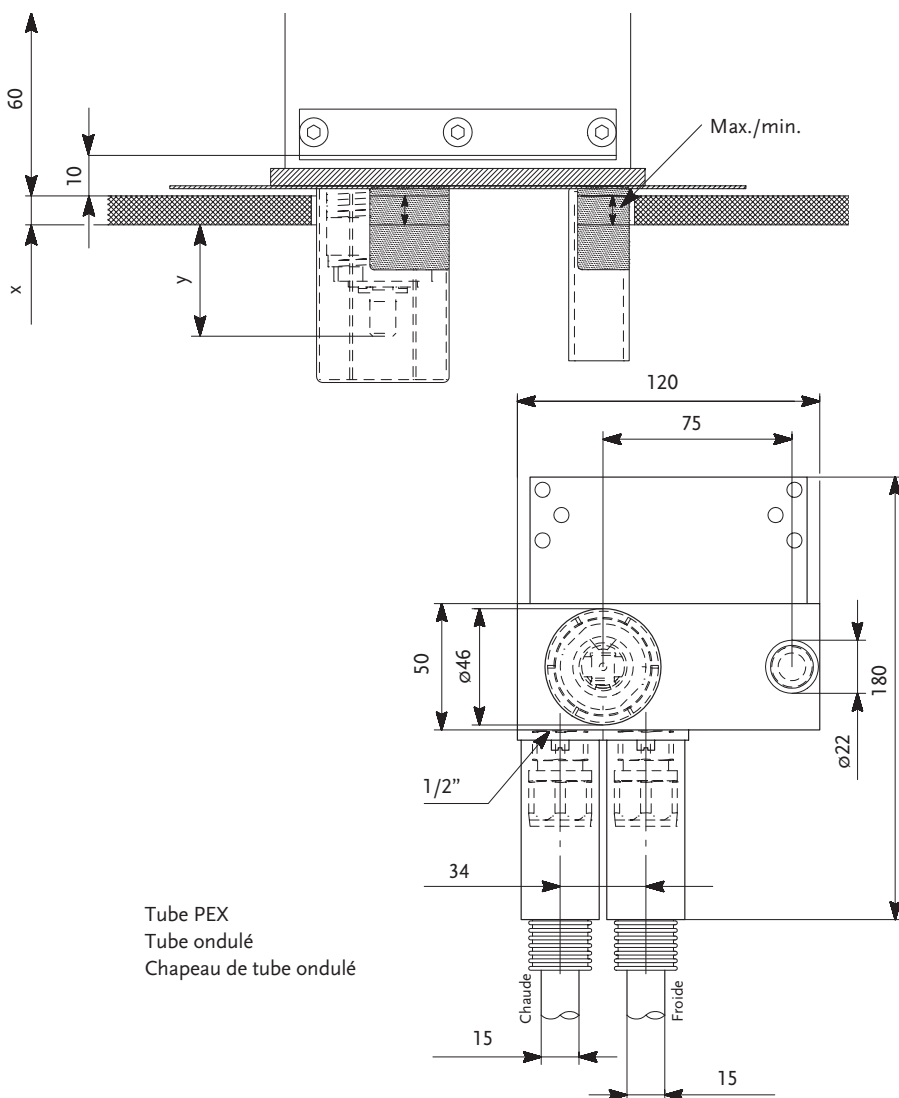

2. Dimensions

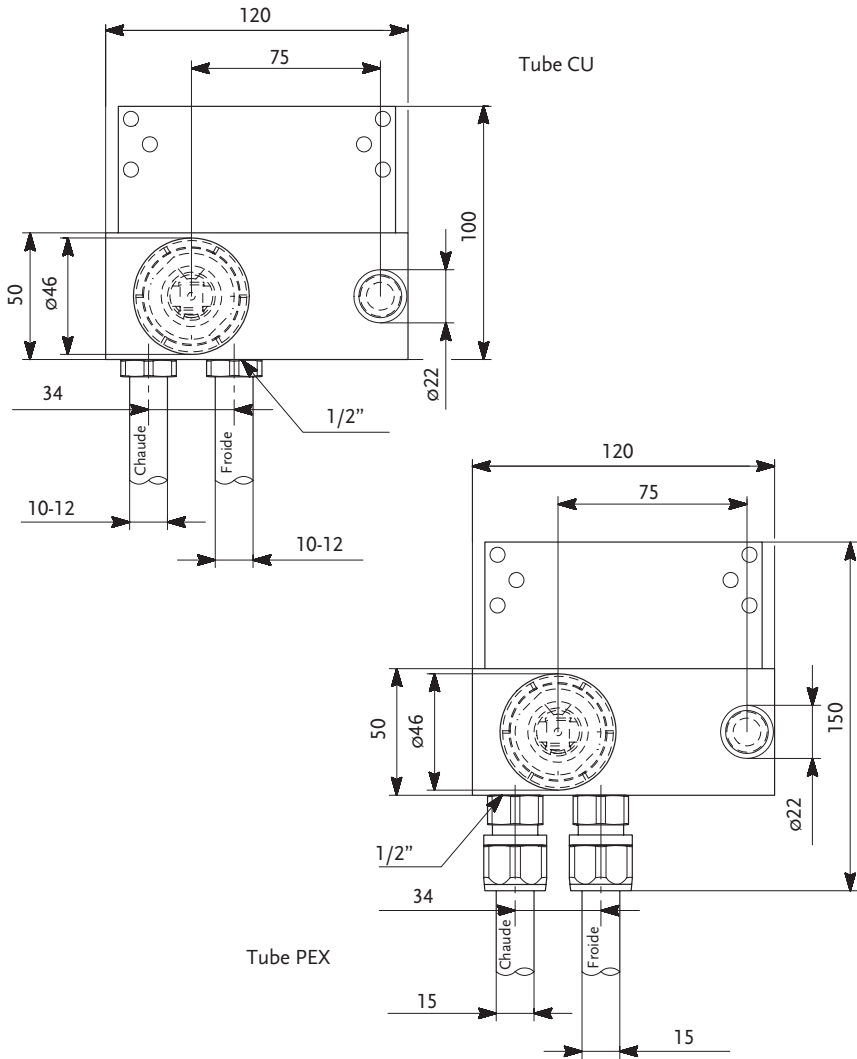

3. Kits d'extension

Epaisseur standard du revêtement mural = de 3 à 13 mm.

En cas de revêtement mural plus épais, des kits d'extension sont disponibles (voir tableau ci-dessous) :

Epaisseur de carreau (x)	Distance de l'extrémité de la tige à la surface extérieure de mur (y)	Type de mitigeur					
		F1335 F1135 F1341 F1141	F1342 F1142 F1336/F1339 F1136/F1139	F1337 F1137 F1338 F1138			
3 - 13 mm	44 - 54 mm	Standard	Standard	Standard			
13 - 23 mm	34 - 44 mm	F960807NU	F960679NU	F960128NU			
23 - 33 mm	24 - 34 mm	F960260NU	F960049NU	F960129NU			
33 - 43 mm	14 - 24 mm	F960262NU	F960452NU	F960130NU			
43 - 53 mm	4 - 14 mm	F960263NU	F960615NU	F960131NU			

4. Instructions de pose de mitigeurs encastrés dans un mur de construction légère (18 mm ou 2 x 13 mm)

Saignée, mur de construction légère - 18 mm
Saignée, mur de construction légère - 2 x 13 mm

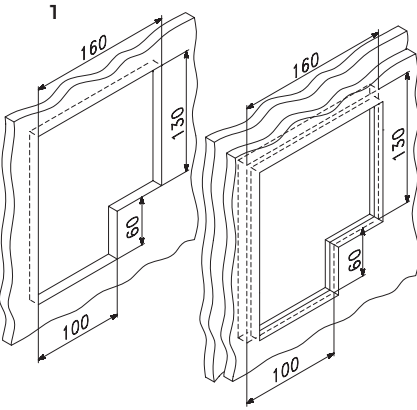

Enrobage - 1^{ère} fois sous membrane caoutchouc

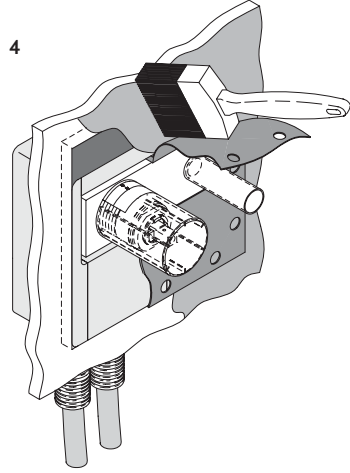

Raccordement 1/2" pour tubes en cuivre, tubes en plastique ou tubes en acier et assemblage de la coque de la coque en styrène

Enrobage - 2^{ème} fois sur membrane caoutchouc

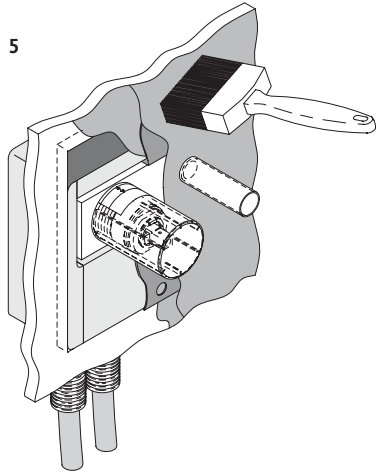
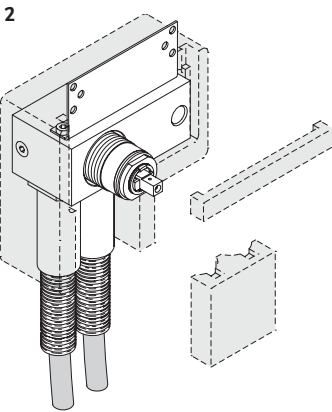

Scellement avec membrane

Revêtement mural, par ex. carrelage

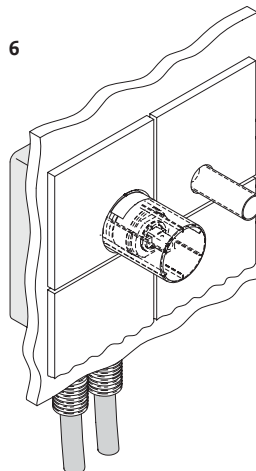
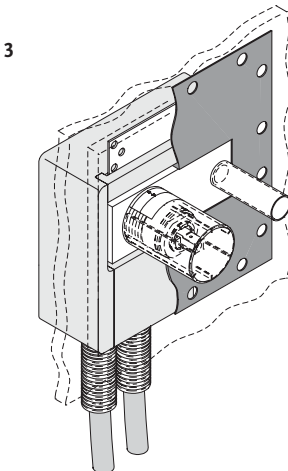

5. Instructions de pose de mitigeurs encastrés dans un mur en briques

Saignée, maçonnerie de brique

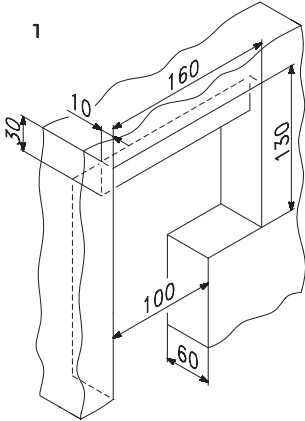

Enrobage - 1^{ère} fois sous membrane caoutchouc

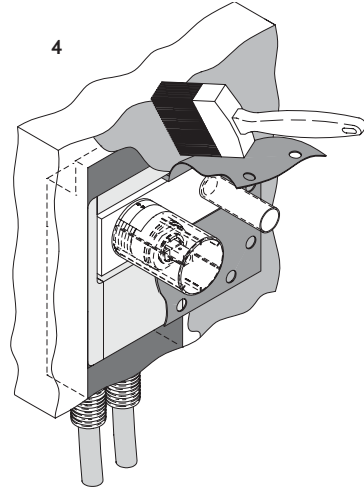

Raccordement 1/2" pour tubes en cuivre, tubes en plastique (tube PEX) ou tubes en acier

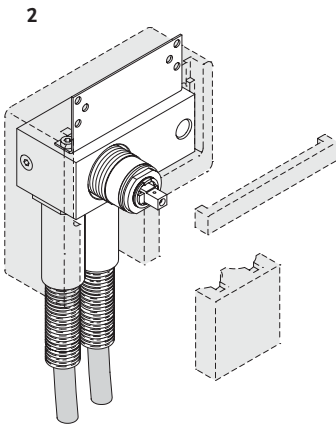

Enrobage - 2^{ème} fois sur membrane caoutchouc

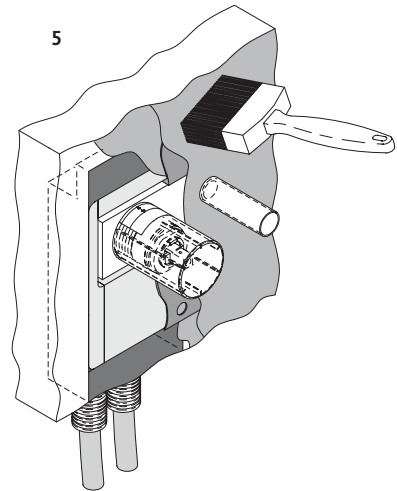

Scellement avec membrane

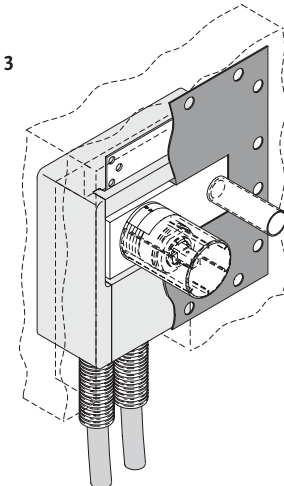

Revêtement mural, par ex. carrelage

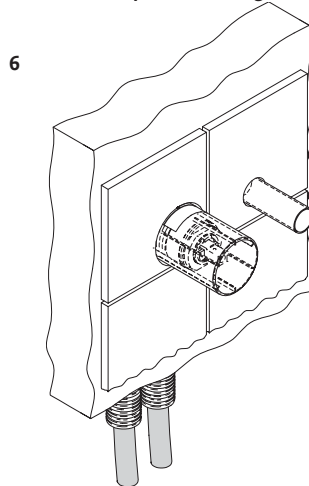

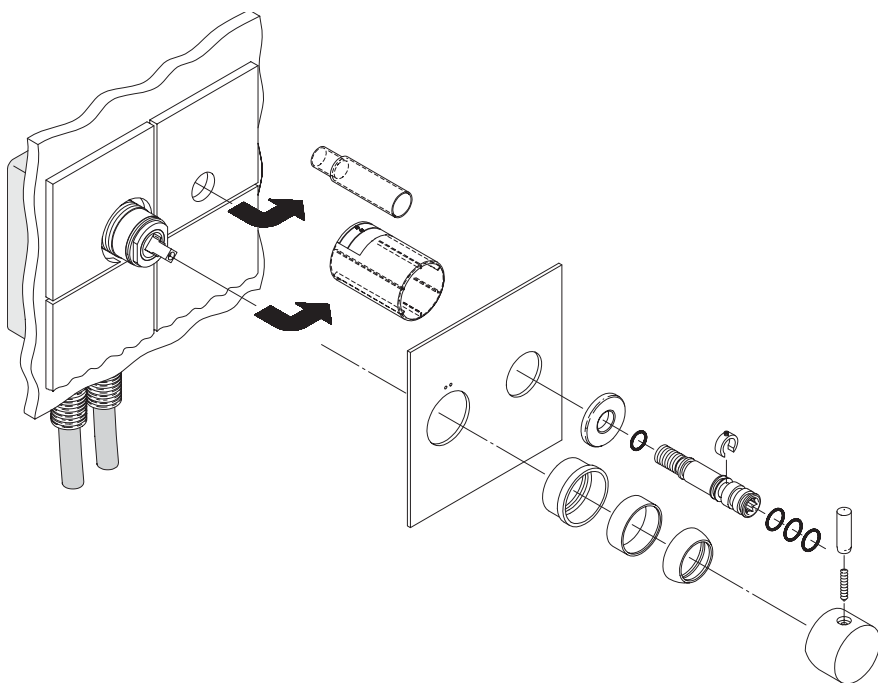
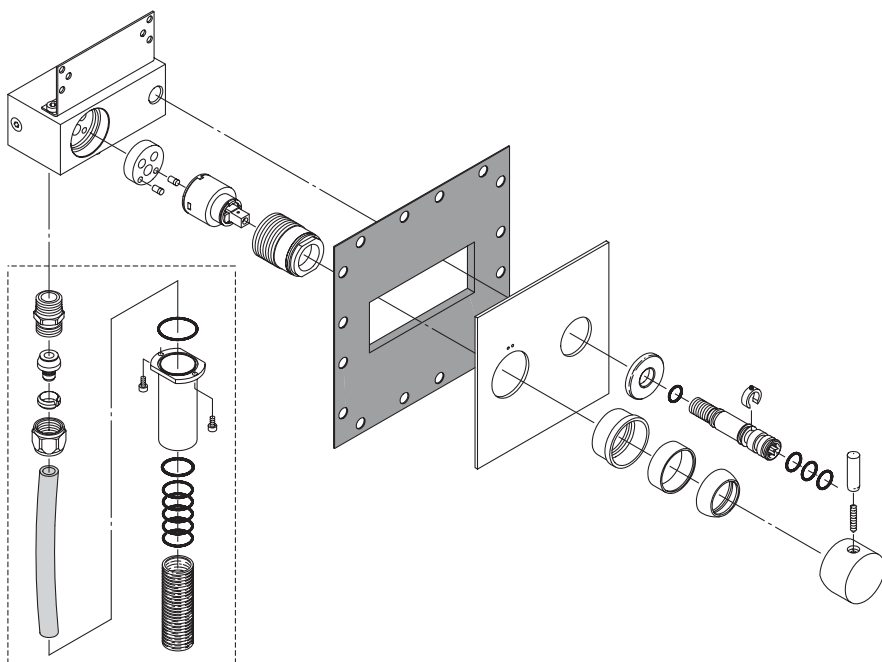
6. Assemblage final**7. Vue éclatée**

Accessoires non inclus !

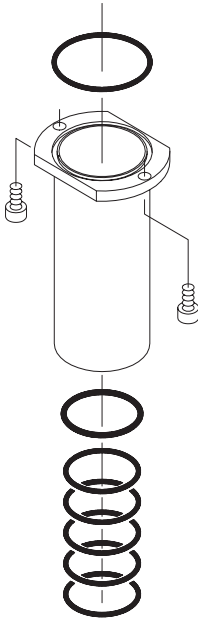

Accessoires pour tube ondulé

Nombre de jeux de chapeaux nécessaires		Réf. n°
	F960747NU	F1335/F1135
		F1336/F1136
		F1337/F1137
1 x		F1338/F1138
		F1339/F1139
		F1341/F1141
		F1342/F1142

Le kit d'accessoires mentionné ci-dessus convient à tous les raccords d'un modèle donné.

Exemple : 1 x kit d'accessoires F960747NU destiné par exemple au modèle F1335 contient tous les raccords nécessaires.

2. Dimensioni

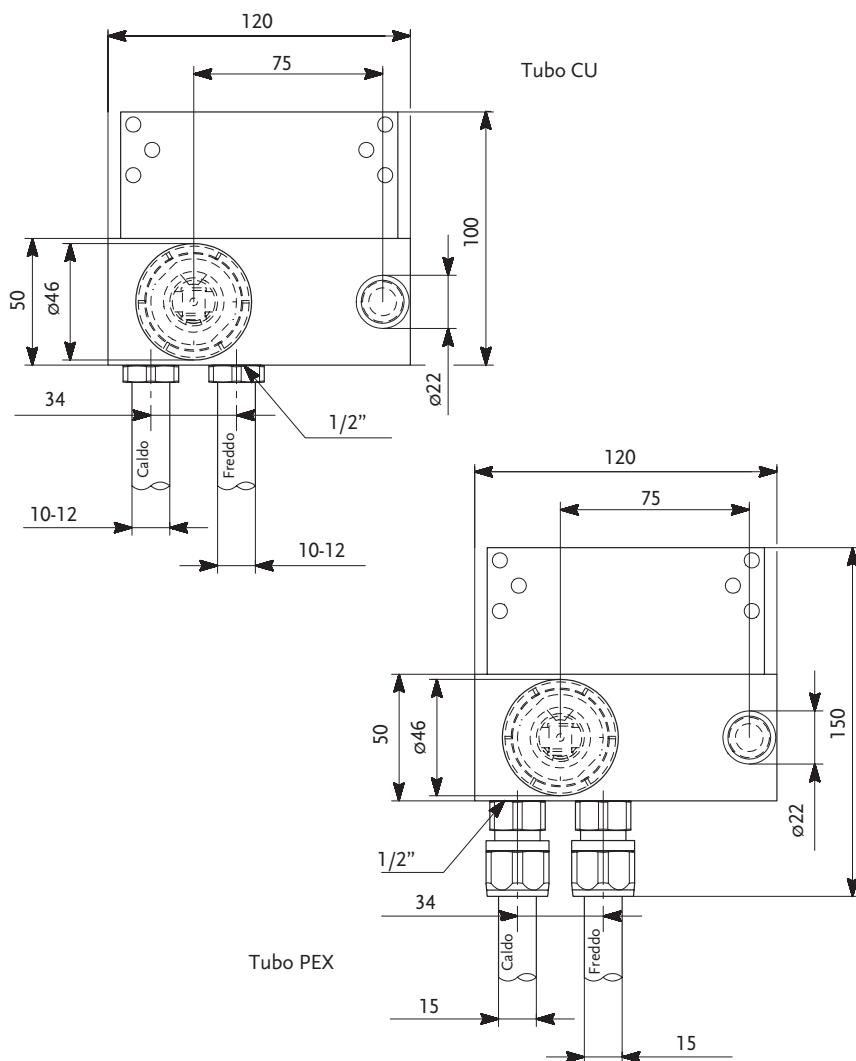

3. Kit di prolunga

Spessore standard del rivestimento parete = 3 - 13 mm.

In caso di rivestimento più spesso, sono disponibili kit di prolunga (vedere la tabella di seguito):

Spessore piastrelle (x)	Dimensioni dall'estremità dell'asta alla superficie esterna della parete (y)	Tipo di miscelatore				
		F1335 F1135 F1341 F1141	F1342 F1142 F1336/F1339 F1136/F1139	F1337 F1137 F1338 F1138		
3 - 13 mm	44 - 54 mm	Standard	Standard	Standard		
13 - 23 mm	34 - 44 mm	F960807NU	F960679NU	F960128NU		
23 - 33 mm	24 - 34 mm	F960260NU	F960049NU	F960129NU		
33 - 43 mm	14 - 24 mm	F960262NU	F960452NU	F960130NU		
43 - 53 mm	4 - 14 mm	F960263NU	F960615NU	F960131NU		

4. Indicazioni per il montaggio dei miscelatori interni in parete leggera (18 mm o 2 x 13 mm)

Sezione, parete leggera - 18 mm
Sezione, parete leggera - 2 x 13 mm

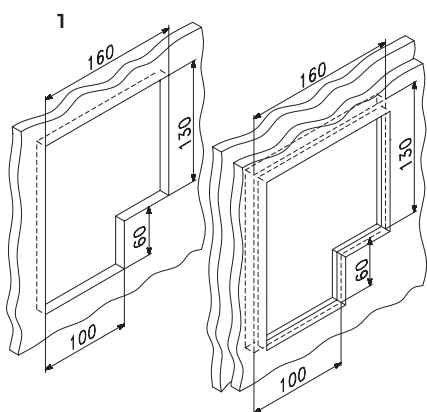

Rivestimento - La prima mano sotto la membrana di gomma

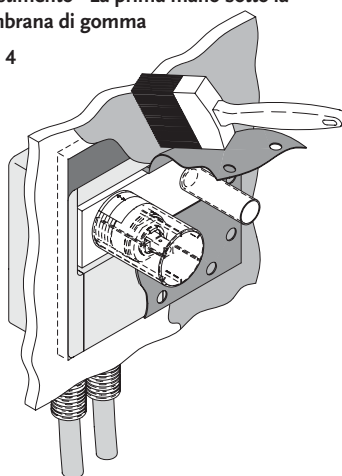

Raccordo 1/2" per condutture di rame, di plastica o d'acciaio e montaggio della scatola di stirene

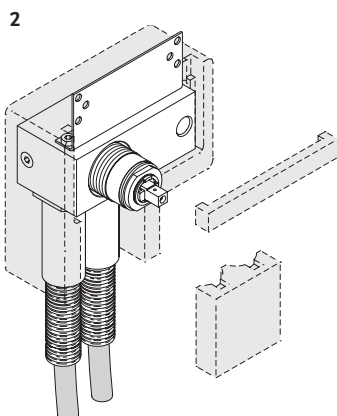

Rivestimento - La seconda mano sopra la membrana di gomma

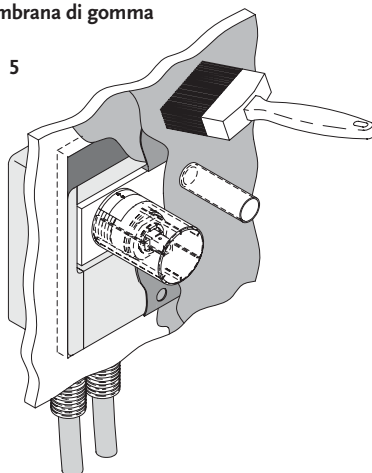

Muratura con membrana

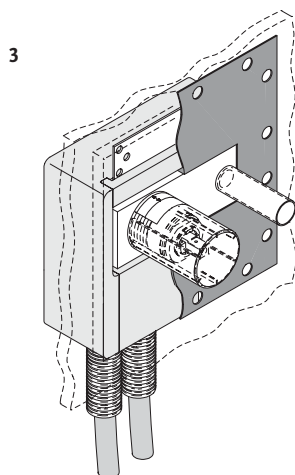

Rivestimento parete, piastrellatura

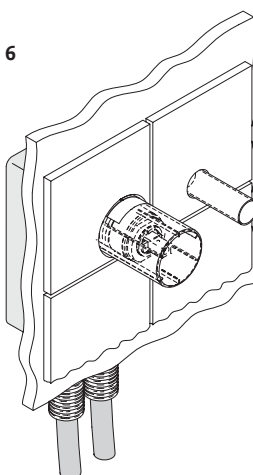

5. Indicazioni per il montaggio dei miscelatori interni in pareti di mattoni

Sezione, muratura in mattoni

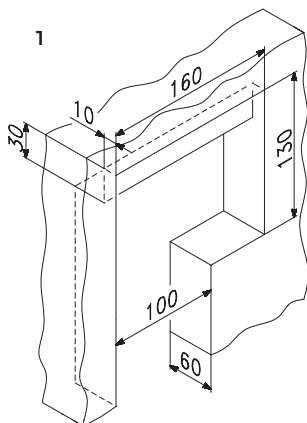

Rivestimento - La prima mano sotto la membrana di gomma

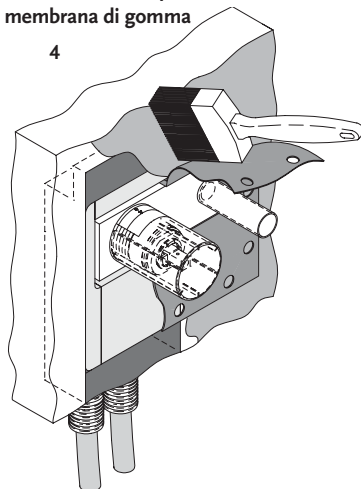

Raccordo 1/2" per tubi di rame, di plastica (tubo PEX) o di acciaio

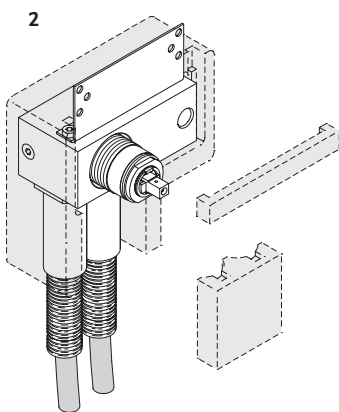

Rivestimento - La seconda mano sopra la membrana di gomma

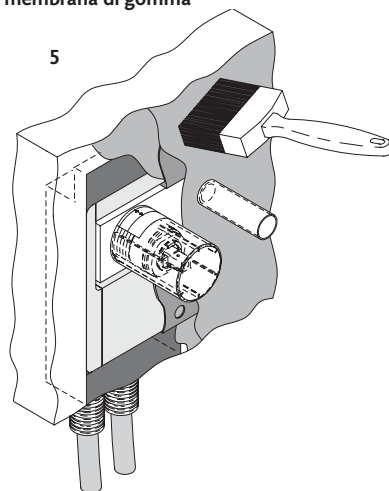

Muratura con membrana

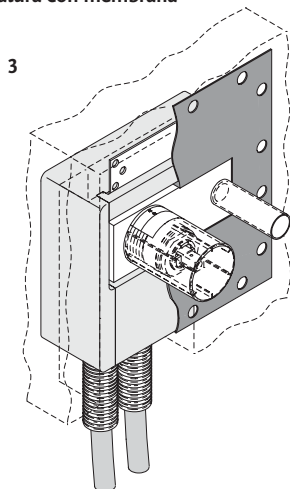

Rivestimento parete, piastrellatura

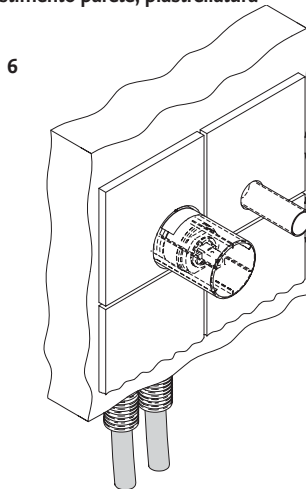

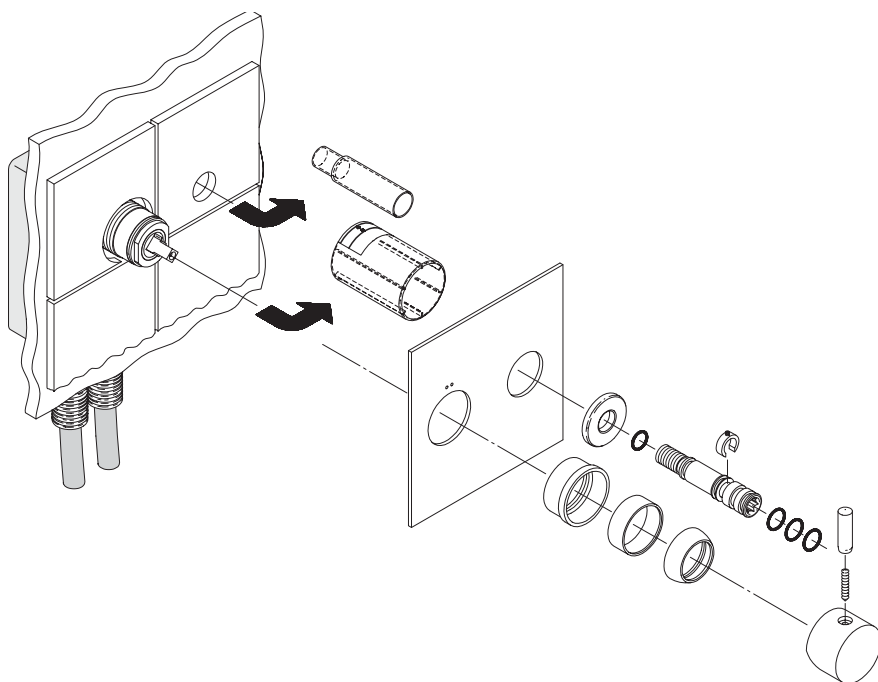
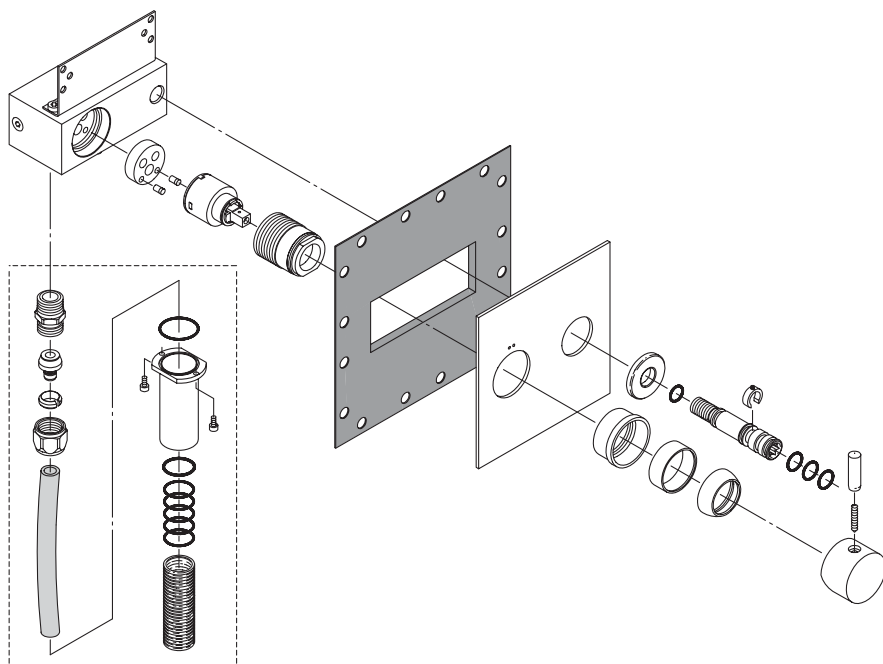
6. Montaggio finale**7. Esploso****Accessori non inclusi!**

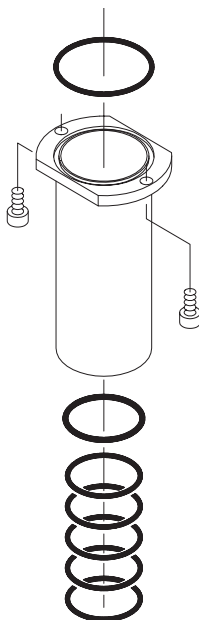

Accessori per tubo corrugato

N. di set calotte necessario		Articolo n.
		F1335/F1135
		F1336/F1136
		F1337/F1137
1 x	F960747NU	F1338/F1138
		F1339/F1139
		F1341/F1141
		F1342/F1142

Il kit di accessori sopra menzionato è idoneo per tutte le connessioni di un determinato modello.

Esempio: 1 x kit di accessori F960747NU per F1335 include tutte le connessioni necessarie.

2. Dimensiones

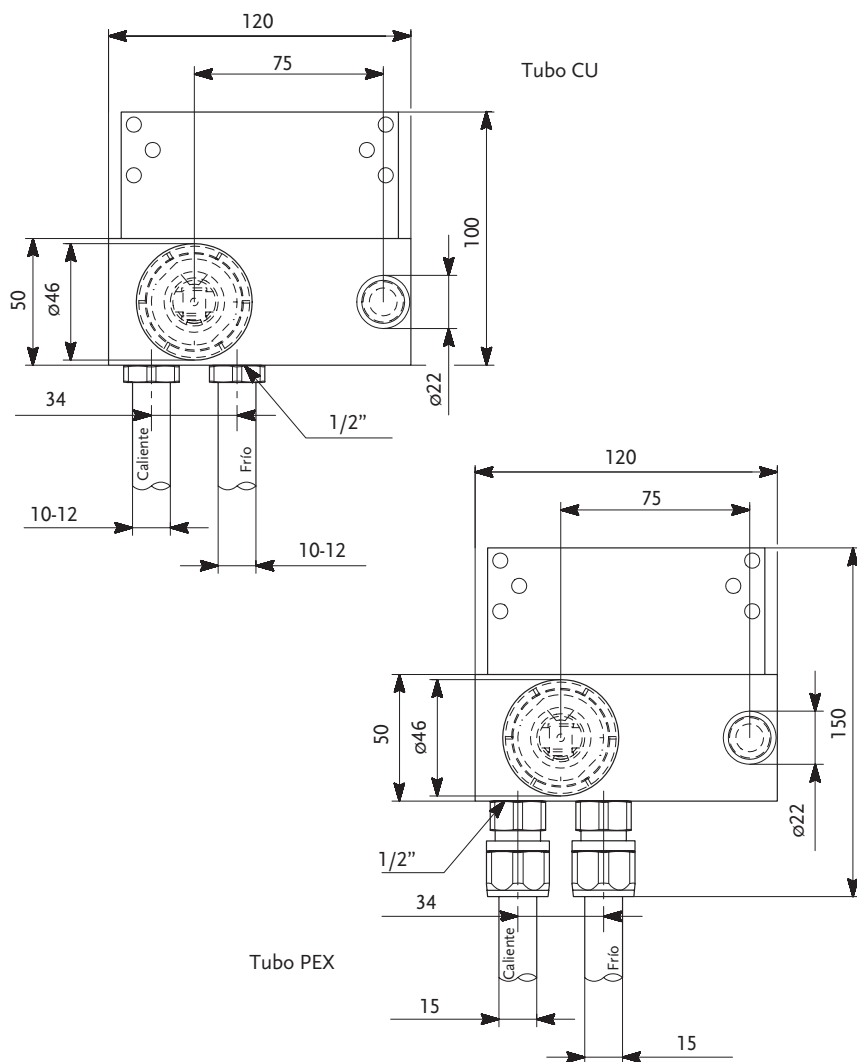

3. Kits de prolongación

Grosor estándar para revestimiento de muros = 3 - 13 mm.

En caso de un revestimiento de muros más grueso, se pueden suministrar kits de prolongación (consulte la siguiente tabla):

Grosor del azulejo (x)	Medida desde el extremo del eje hasta la superficie exterior de la pared (y)	Tipo de mezclador				
		F1335 F1135 F1341 F1141	F1342 F1142 F1336/F1339 F1136/F1139	F1337 F1137 F1338 F1138		
3 - 13 mm	44 - 54 mm	Estándar	Estándar	Estándar		
13 - 23 mm	34 - 44 mm	F960807NU	F960679NU	F960128NU		
23 - 33 mm	24 - 34 mm	F960260NU	F960049NU	F960129NU		
33 - 43 mm	14 - 24 mm	F960262NU	F960452NU	F960130NU		
43 - 53 mm	4 - 14 mm	F960263NU	F960615NU	F960131NU		

4. Directrices para el montaje de mezcladores empotrados en paredes delgadas (18 mm o 2 x 13 mm)

Desgastado, pared delgada - 18 mm
Desgastado, pared delgada - 2 x 13 mm

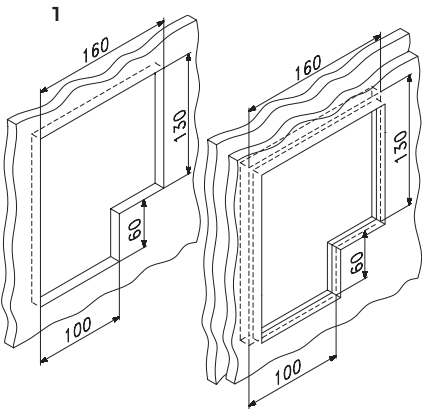

Revestimiento - 1ª vez bajo la membrana de caucho

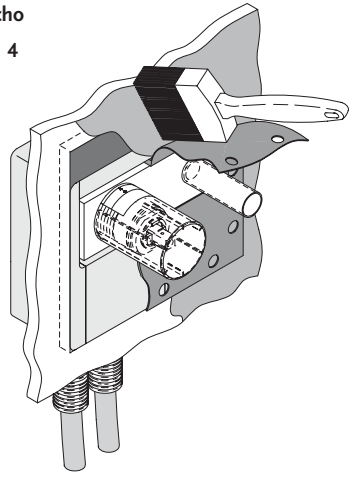

1/2" conexión para tubos de cobre, tubos de plástico, o tubos de acero y montaje de caja de estireno

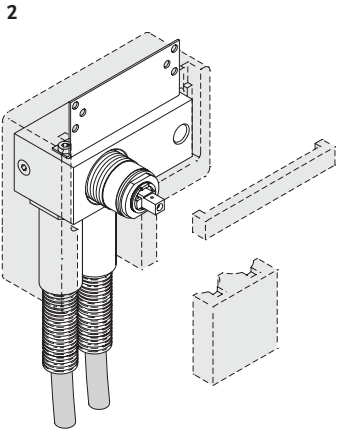

Revestimiento - 2ª vez sobre la membrana de caucho

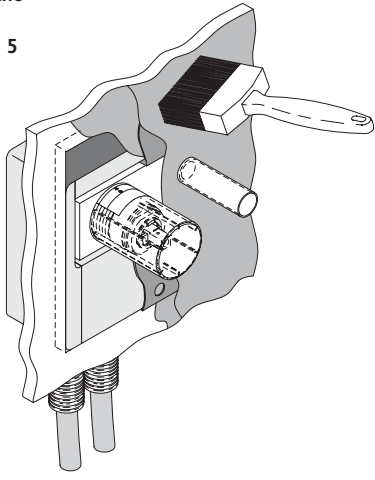

Recubrimiento con membrana

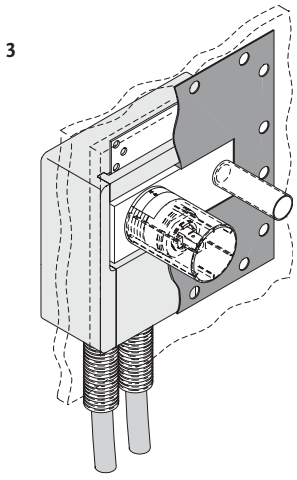

Revestimiento, p.ej., azulejos

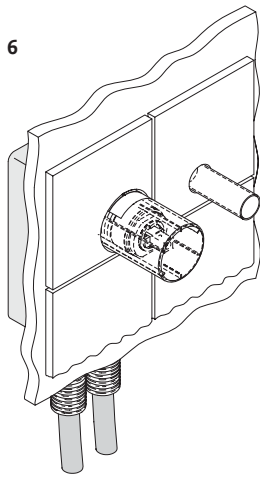

5. Directrices para el montaje de mezcladores empotrados en paredes de ladrillo

Desgastada, obra de ladrillo

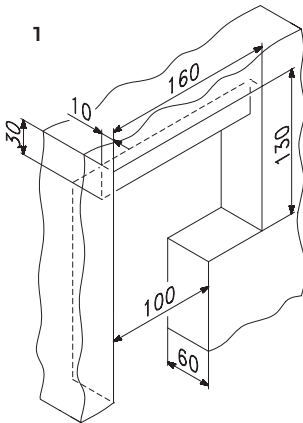

Revestimiento - 1ª vez bajo la membrana de caucho

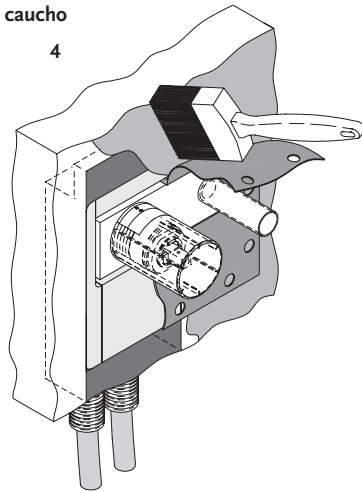

1/2" conexión para tubos de cobre, tubos de plástico (tubo PEX), o tubos de acero

2

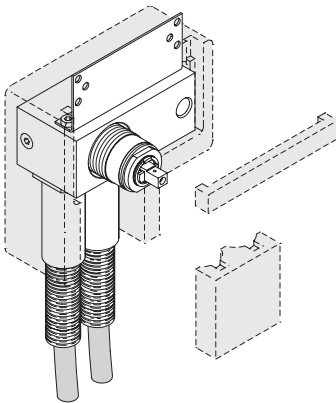

Revestimiento - 2ª vez sobre la membrana de caucho

5

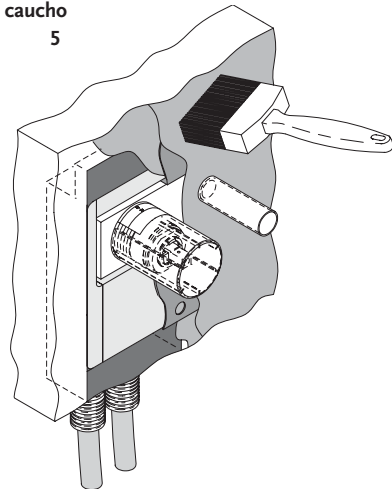

Recubrimiento con membrana

3

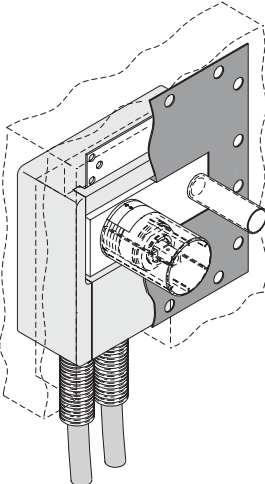

Revestimiento, p.ej., azulejos

6

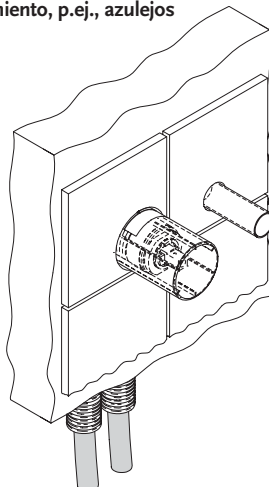

6. Montaje final

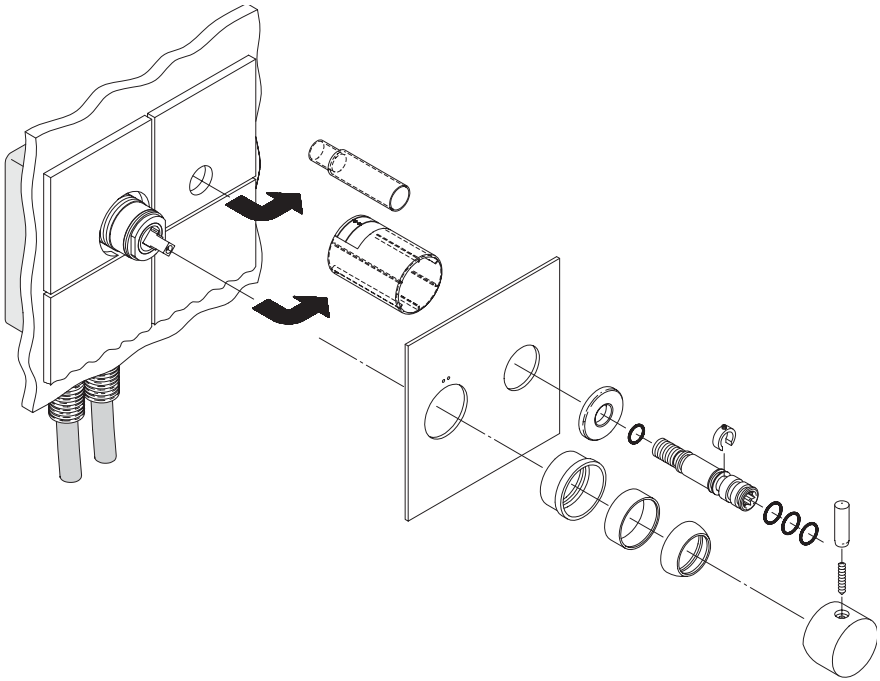

7. Vista detallada

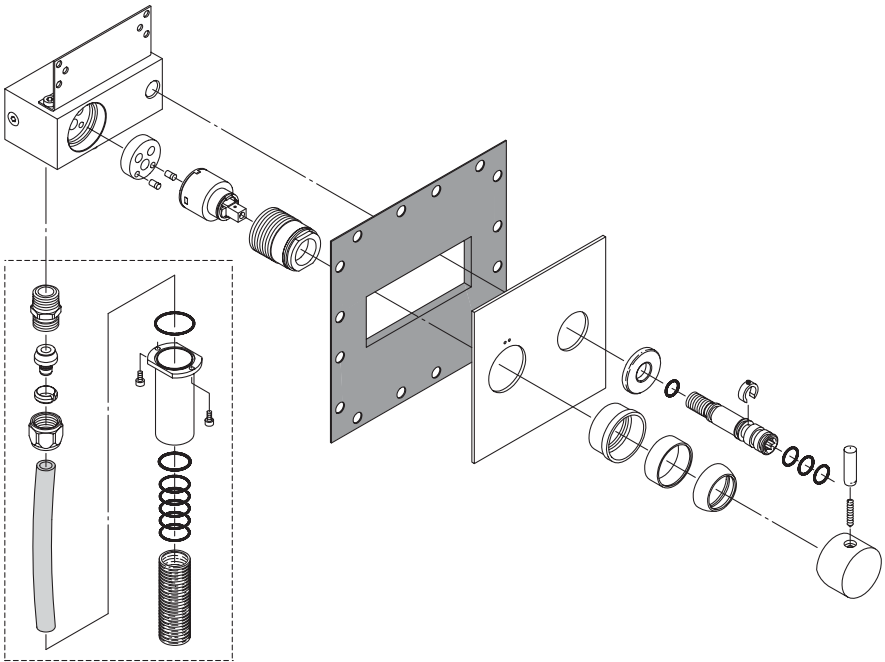

¡Accesorios no incluidos!

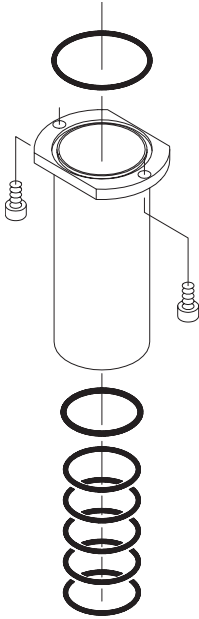

Accesorios para tubo corrugado

N° de juegos de tapones roscados necesarios		Artículo n°
1 x	F960747NU	F1335/F1135 F1336/F1136 F1337/F1137 F1338/F1138 F1339/F1139 F1341/F1141 F1342/F1142

El kit de accesorios arriba mencionado es apropiado para todas las conexiones de un modelo determinado. Ejemplo: 1 x kit de accesorios F960747NU, p.ej., para F1335 incluye todas las conexiones necesarias.

1. Limpeza das misturadoras

A superfície e o funcionamento de cada misturadora foram inspeccionados, tendo as misturadoras sido verificadas uma a uma antes de saírem da fábrica.

Para proteger e conservar a superfície, siga as instruções abaixo:

Superfícies cromadas

As superfícies cromadas bem como as superfícies de latão polidas devem ser limpas com um pano macio e materiais de limpeza líquidos, não ácidos e sem abrasivos ou com água com sabão.

Superfícies esmaltadas coloridas

Estas superfícies perderão o seu aspecto brilhante se forem limpas com materiais contendo abrasivos. Utilize apenas água limpa ou detergente diluído. Os resíduos de calcário podem ser retirados com o vulgar vinagre caseiro.

Arejadores

Calcário nos arejadores: mergulhe o arejador em vinagre caseiro até o calcário dissolver.

Resíduos de calcário

Os resíduos de calcário podem ser retirados com o vulgar vinagre caseiro.

2. Dimensões

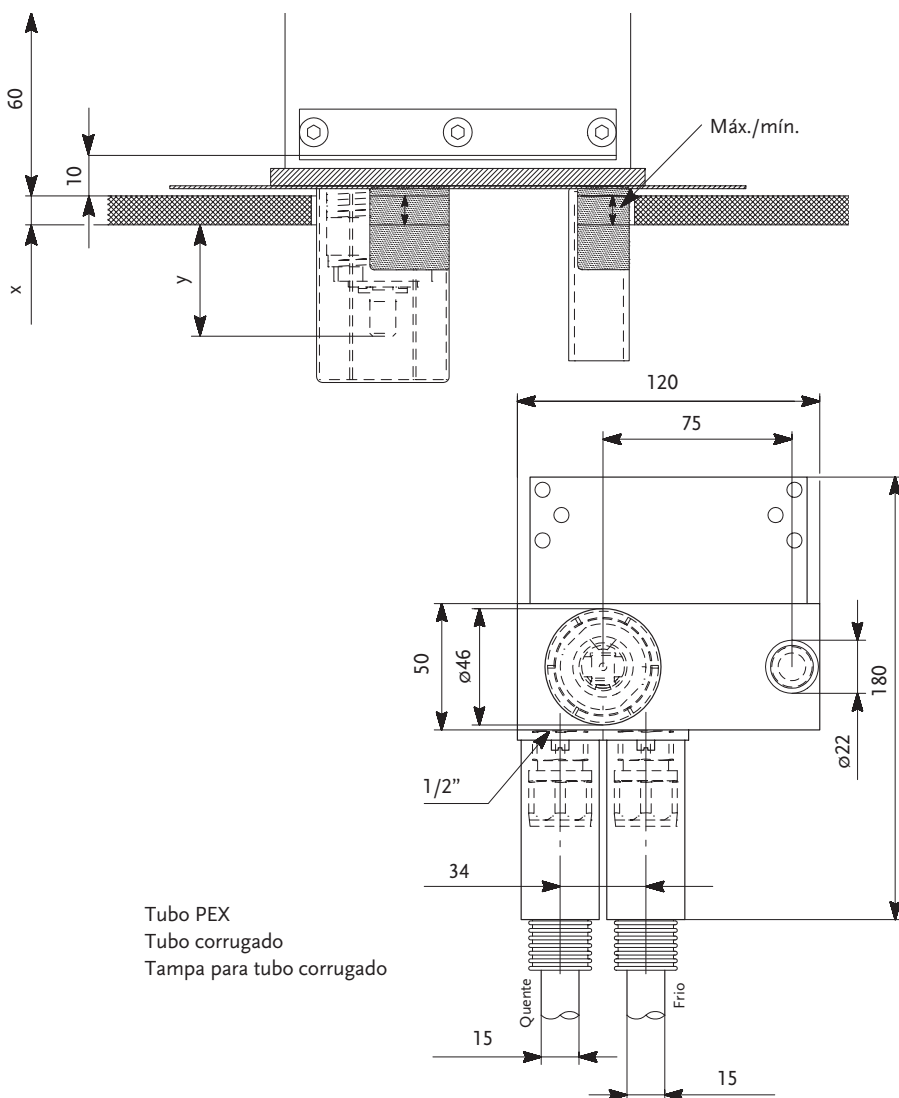

2. Dimensões

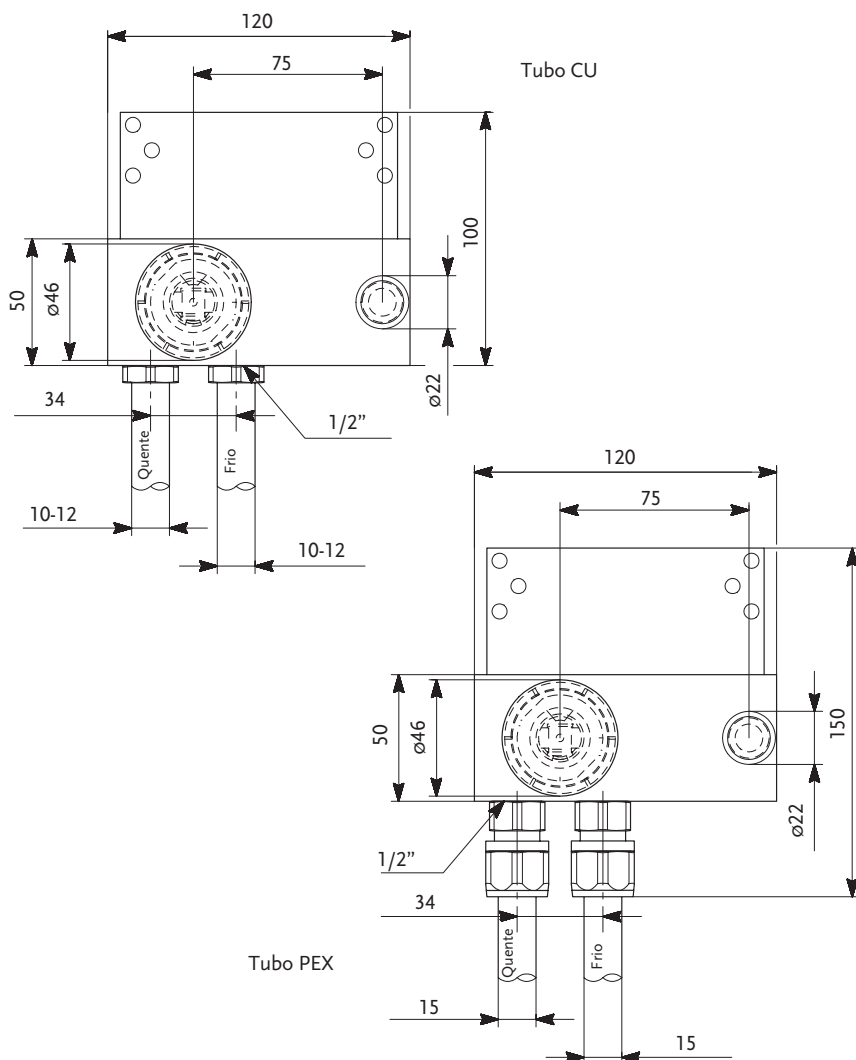

3. Kits de extensão

Espessura standard do revestimento de parede = 3 - 13 mm.

No caso de um revestimento de parede mais grosso, poderão ser fornecidos kits de extensão (ver tabela a seguir):

Espessura do azulejo (x)	Dimensão da extremidade do fuso à superfície exterior da parede (y)	Tipo de misturadora				
		F1335 F1135 F1341 F1141	F1342 F1142 F1336/F1339 F1136/F1139	F1337 F1137 F1338 F1138		
3 - 13 mm	44 - 54 mm	Standard	Standard	Standard		
13 - 23 mm	34 - 44 mm	F960807NU	F960679NU	F960128NU		
23 - 33 mm	24 - 34 mm	F960260NU	F960049NU	F960129NU		
33 - 43 mm	14 - 24 mm	F960262NU	F960452NU	F960130NU		
43 - 53 mm	4 - 14 mm	F960263NU	F960615NU	F960131NU		

4. Instruções para montagem de misturadoras ocultas em paredes finas (18 mm ou 2 x 13 mm)

Recorte, parede fina - 18 mm
 Recorte, parede fina - 2 x 13 mm

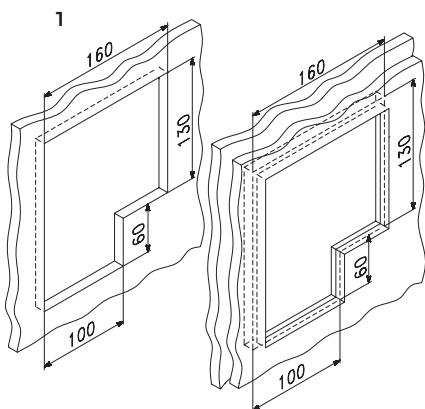

Camada - 1ª vez sob membrana de borracha

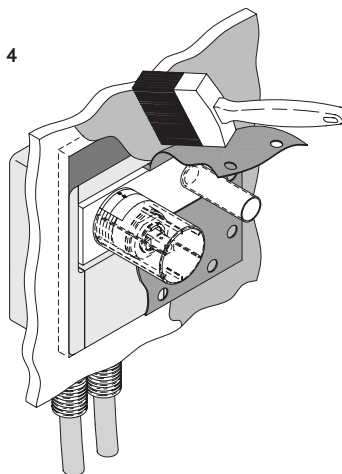

Ligação de 1/2" para tubos de cobre, tubos de plástico ou tubos de aço e montagem de caixa de estireno

Camada - 2ª vez sobre membrana de borracha

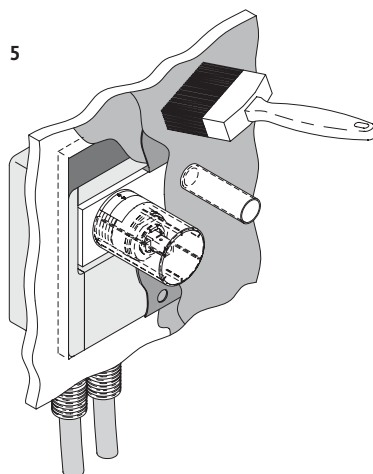
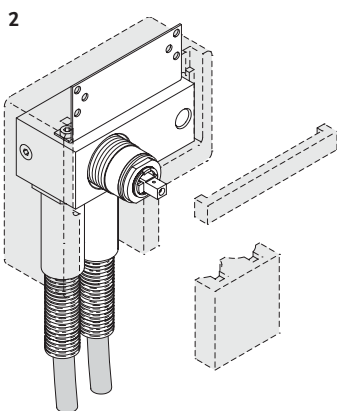

Tapar com membrana

Revestimento de parede, por exemplo, azulejos

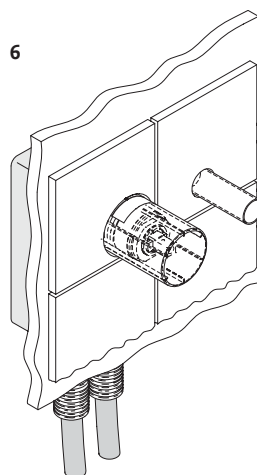
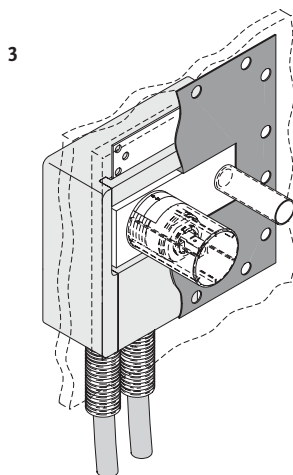

5. Instruções para montagem de misturadoras ocultas em paredes de tijolo

Recorte, construção de tijolo

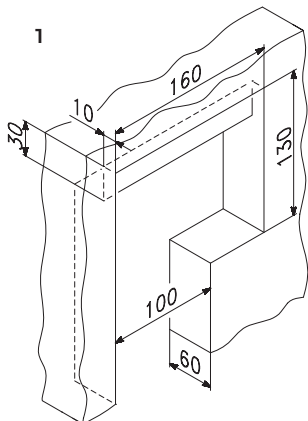

Camada - 1ª vez sob membrana de borracha

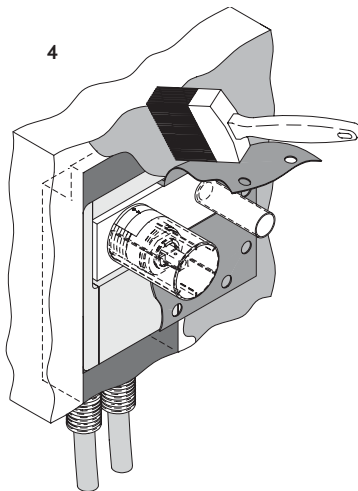

Ligação de 1/2" para tubos de cobre, tubos de plástico (tubo PEX) ou tubos de aço

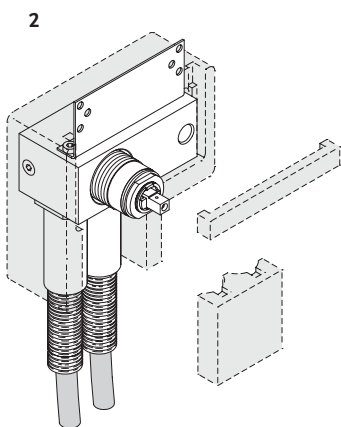

Camada - 2ª vez sobre membrana de borracha

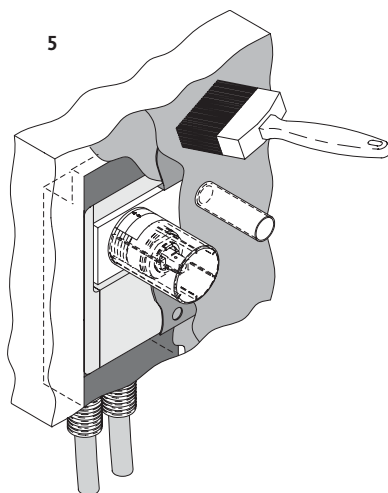

Tapar com membrana

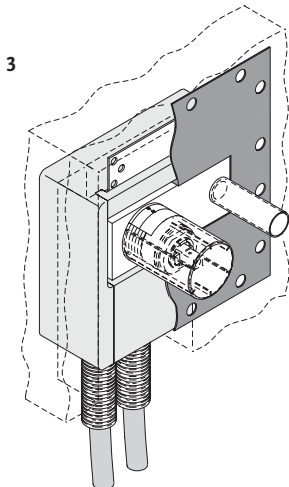

Revestimento de parede, por exemplo, azulejos

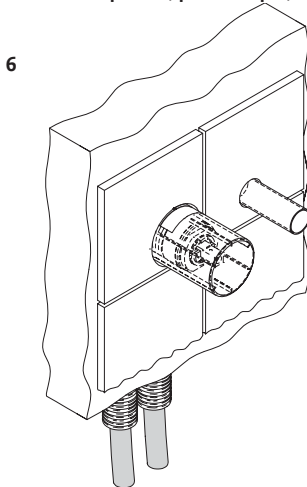

6. Montagem final

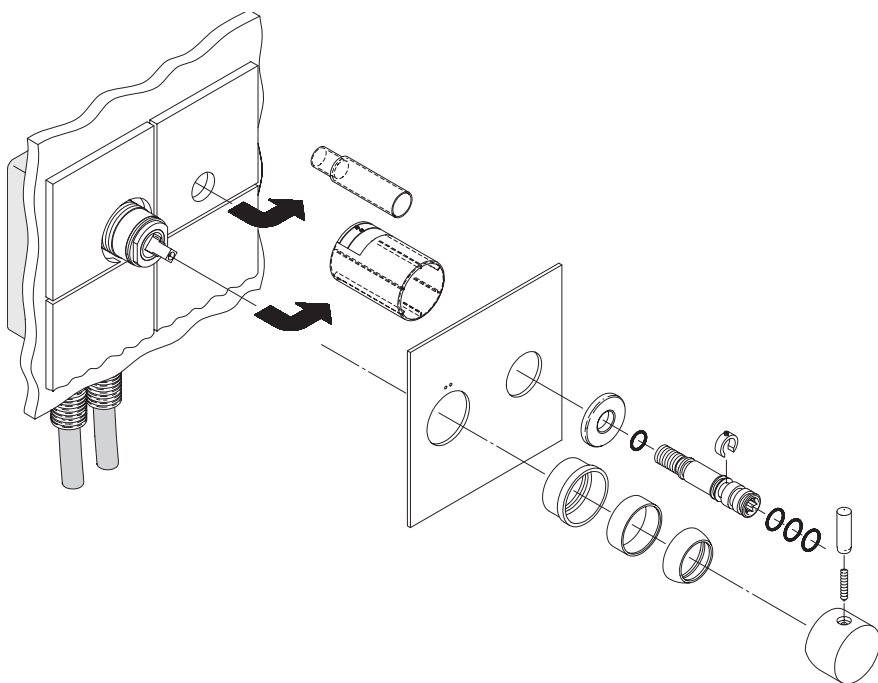

7. Vista em destaque dos componentes

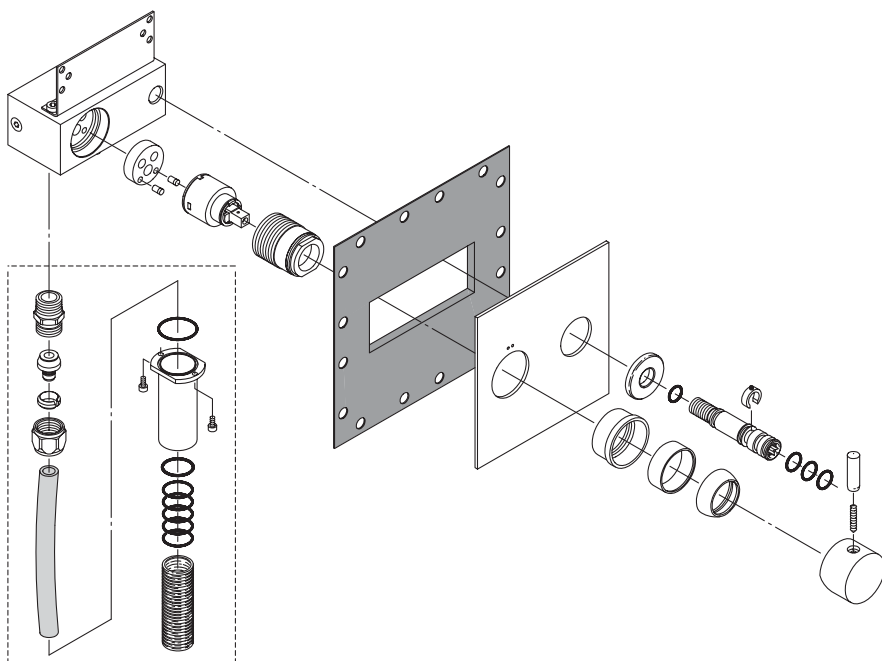

Accessórios não incluídos!

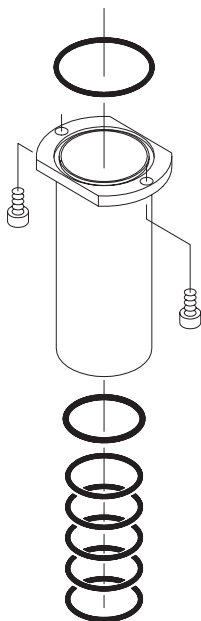

Acessório para tubo corrugado

N.º de conjuntos de tampas necessários		Artigo n.º
		F1335/F1135
		F1336/F1136
		F1337/F1137
1 x	F960747NU	F1338/F1138
		F1339/F1139
		F1341/F1141
		F1342/F1142

O kit de acessórios acima mencionado é adequado para todas as ligações de um determinado modelo.
Exemplo: 1 x kit de acessórios F960747NU, por exemplo, F1335 inclui todas as ligações necessárias.

2. Afmetingen

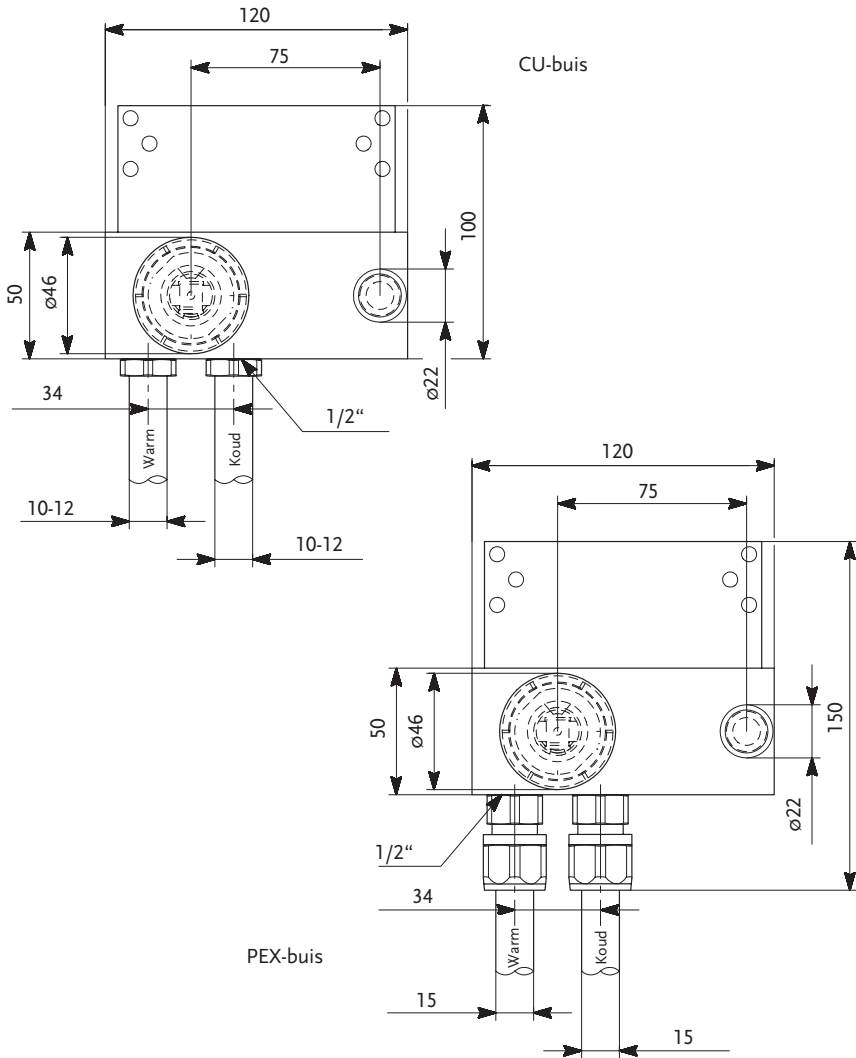

3. Verlengsets

Standaarddikte wandbekleding = 3 - 13 mm.

Voor dickere wandbekledingen zijn verlengsets verkrijgbaar (zie onderstaande tabel):

Tegeldikte (x)	Afmeting van spileind tot buitenoppervlak wand (y)	Type mengkraan				
		F1335 F1135 F1341 F1141	F1342 F1142 F1336/F1339 F1136/F1139	F1337 F1137 F1338 F1138		
3 - 13 mm	44 - 54 mm	Standaard	Standaard	Standaard		
13 - 23 mm	34 - 44 mm	F960807NU	F960679NU	F960128NU		
23 - 33 mm	24 - 34 mm	F960260NU	F960049NU	F960129NU		
33 - 43 mm	14 - 24 mm	F960262NU	F960452NU	F960130NU		
43 - 53 mm	4 - 14 mm	F960263NU	F960615NU	F960131NU		

4. Richtlijnen voor montage van inbouwmengkranen in lichtgewicht wanden (18 mm of 2 x 13 mm)

Uitsparing, lichtgewicht wand - 18 mm

Uitsparing, lichtgewicht wand - 2 x 13 mm

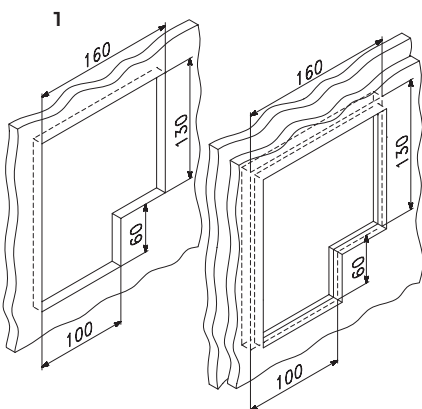

Coating - 1^e maal onder rubber membraan

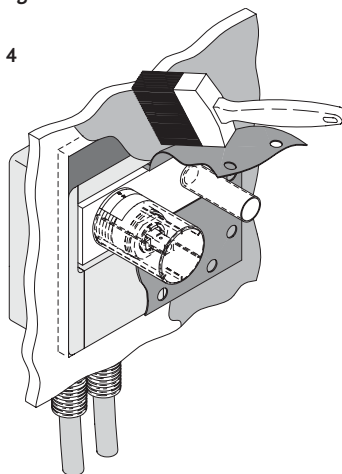

1/2" aansluiting voor koperen, plastic of stalen leidingen en montage van styreendoos

Coating - 2^e maal over rubber membraan heen

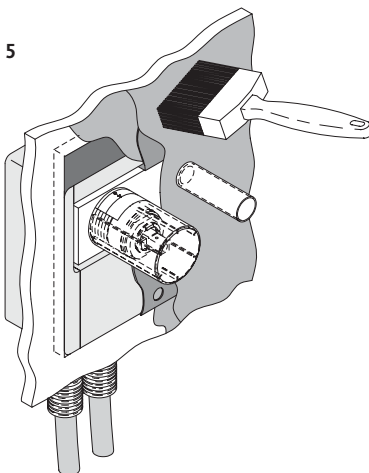
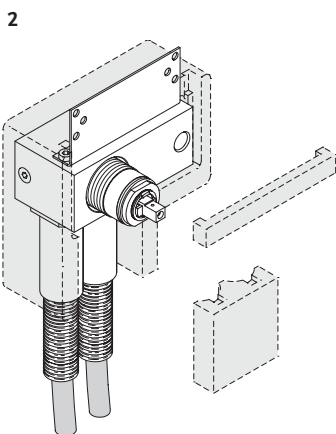

Dichtmaken met membraan

Wandbekleding, bijv. tegelwerk

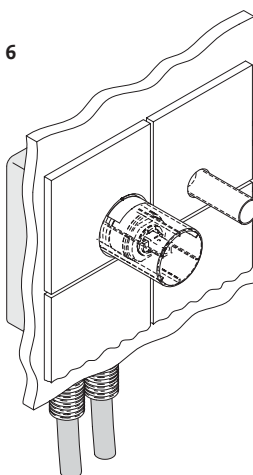
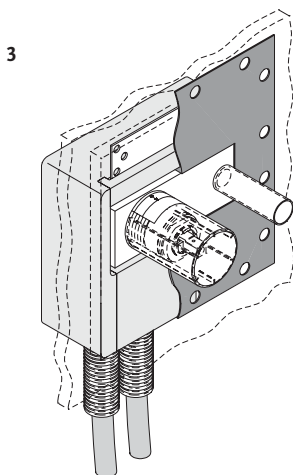

5. Richtlijnen voor montage van inbouwmengkranen in gemetselde muren

Uitsparing, metselwerk

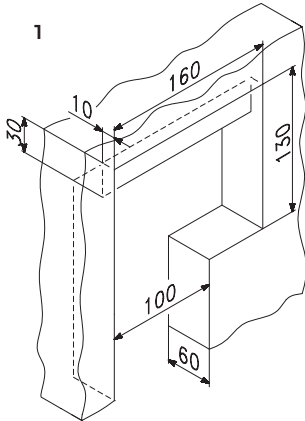

Coating - 1^e maal onder rubber membraan

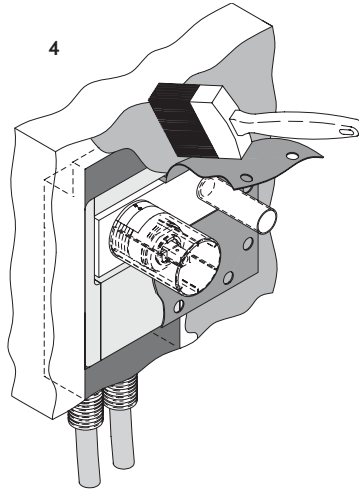

1/2" aansluiting voor koperen, plastic (PEX) of stalen leidingen

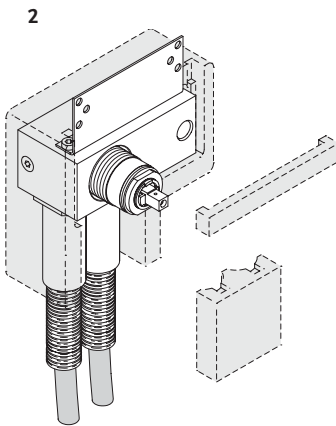

Coating - 2^e maal over rubber membraan heen

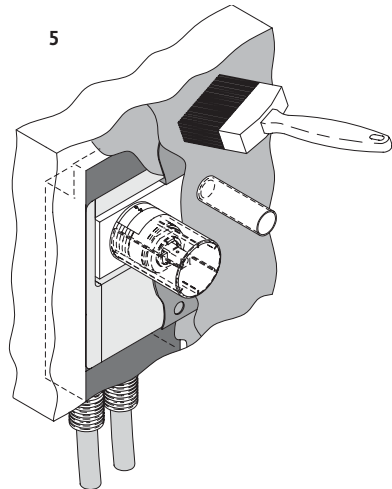

Dichtmaken met membraan

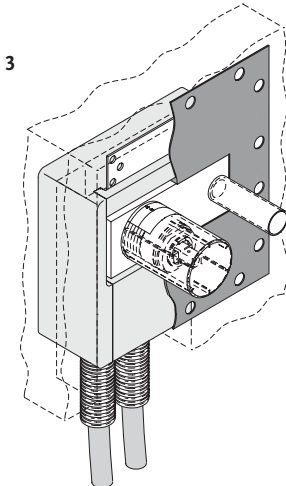

Wandbekleding, bijv. tegelwerk

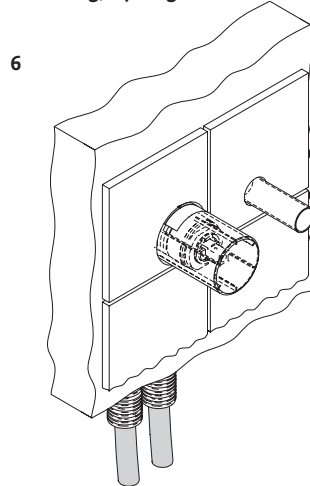

6. Eindmontage

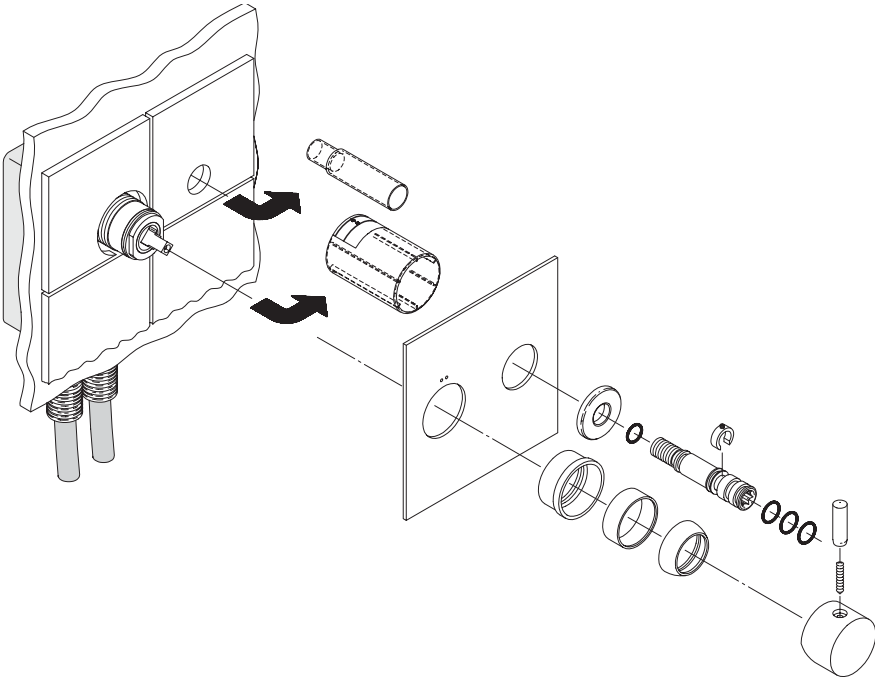

7. Opengewerkte tekening

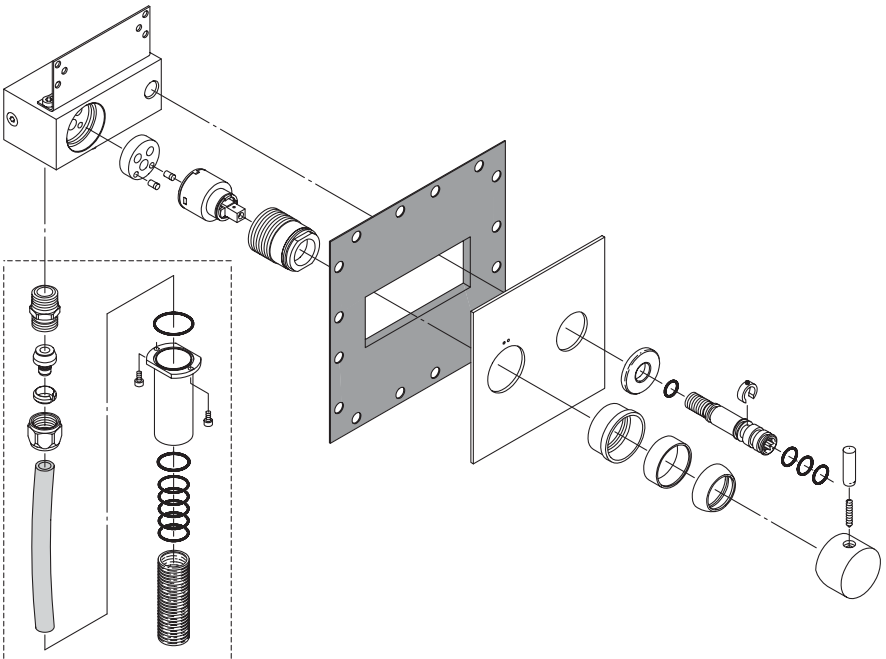

Accessoires niet meegeleverd!

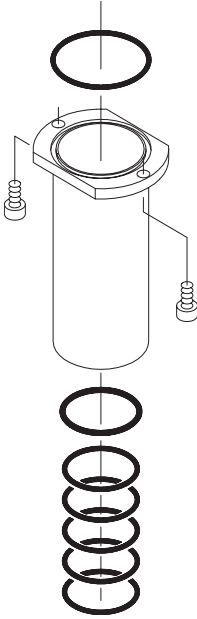

Accessoireset voor ribbelbuis

Aantal benodigde dopsets		Artikelnr.
		F1335/F1135 F1336/F1136 F1337/F1137 F1338/F1138 F1339/F1139 F1341/F1141 F1342/F1142
1 x	F960747NU	

Bovenstaande accessoireset is geschikt voor alle aansluitingen van een gegeven model.
 Voorbeeld: 1 x accessoireset F960747NU voor bijv. F1335 bevat alle benodigde verbindingen.







United Kingdom

Ideal Standard National Avenue Hull England HU5 4HS
TEL.: 01482 499685

Germany

pro-Service Euskirchener Straße 80 D-63322 Rödemark
Tel.: +49 (0) 228-521580 Fax: +49 (0) 228-521589
www.pro-service.info E-mail: pro-service.info@aseur.com

France

Ideal Standard France Bat.H, 165 Av. du Bois de la pie, Paris N2
95920 Roissy CDG Tel.: +43 0149 388 181 www.idealstandard.fr

Scandinavian

Ideal Standard Scandinavia A/S Tulipvej 1 DK-7100 Vejle
Tel.: +45 75 84 10 10 Fax: +45 75 84 10 24 www.borma.dk

Nederland

Ideal Standard Nederland L.J.Costerstraat 30 Postbus 7 5900 AA Venlo
Tel.: +31 77 355 08 07

Italiano

Ideal Standard Divisione di American Standard italia S.r.l.
Via Domodosola, 19 20145 Milano Tel.: +39 800 652290

Espaniól

Ideal Standard, S.L. Sant marti, s/n
08107 Martorelles (Barcelona) Tel. General +34 93 5 44 01 60

Portogal

Ideal Standard Portogal Nogueira - Ap. 4 4711 - 909 Braga
08107 Martorelles (Barcelona) Tel.: +253 240001 e-mail: silvaj@aseur.com