

i A

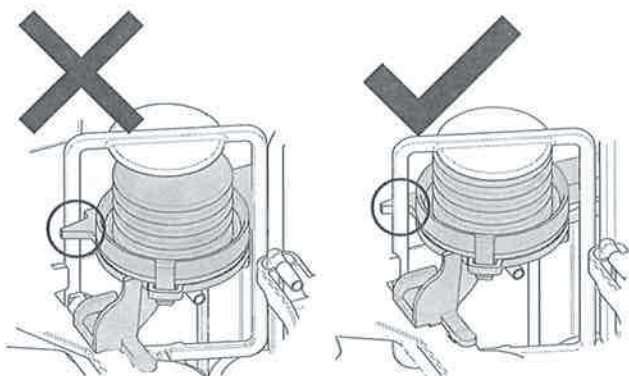

i B

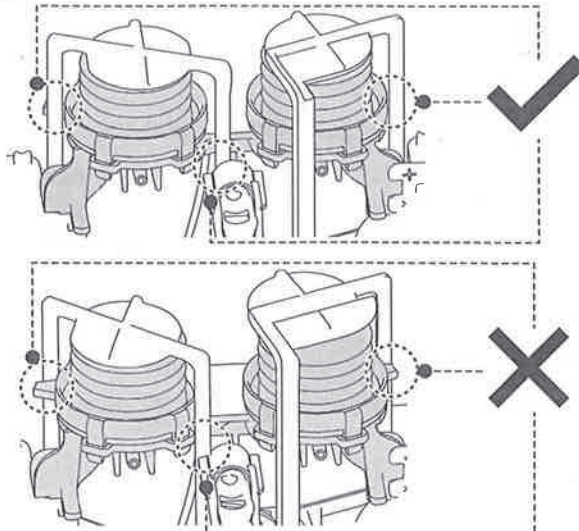

8 A

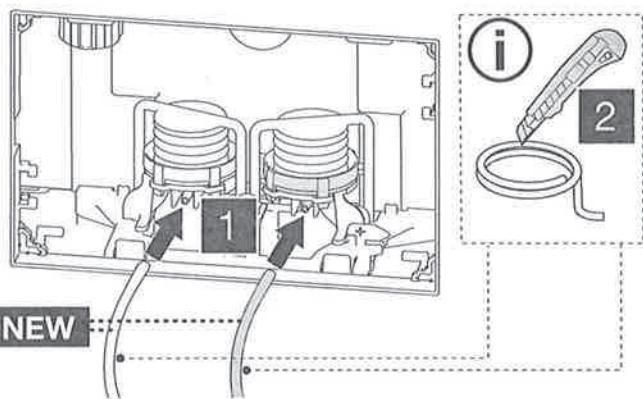

8 B

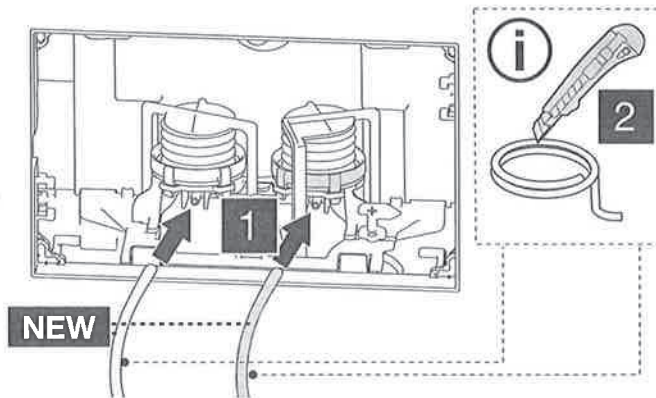

4 A

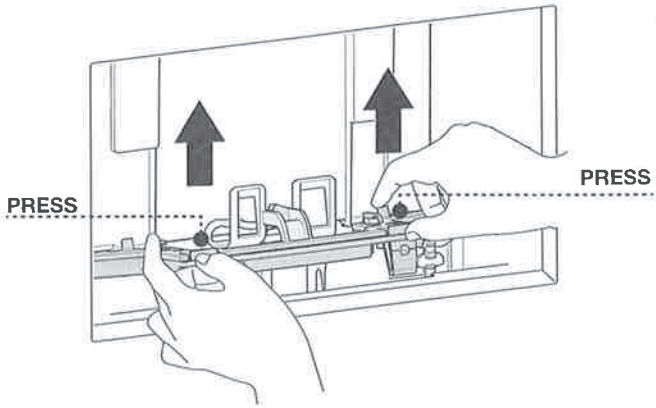

4 B

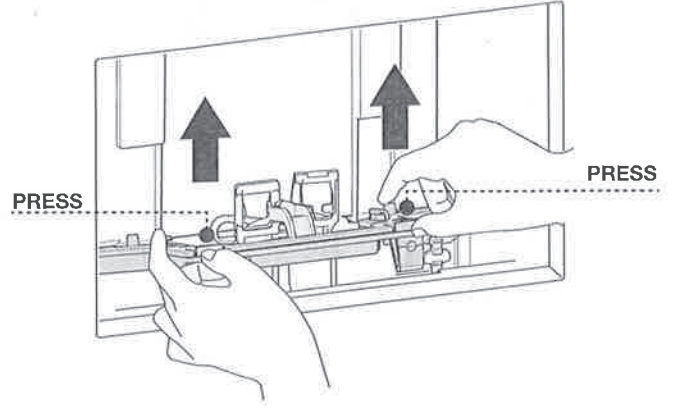

5 A

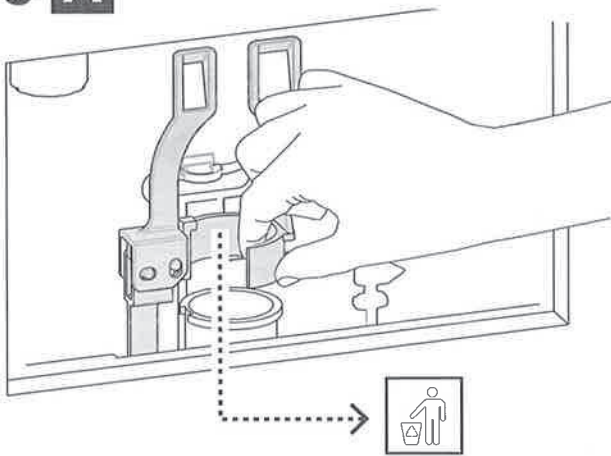

5 B

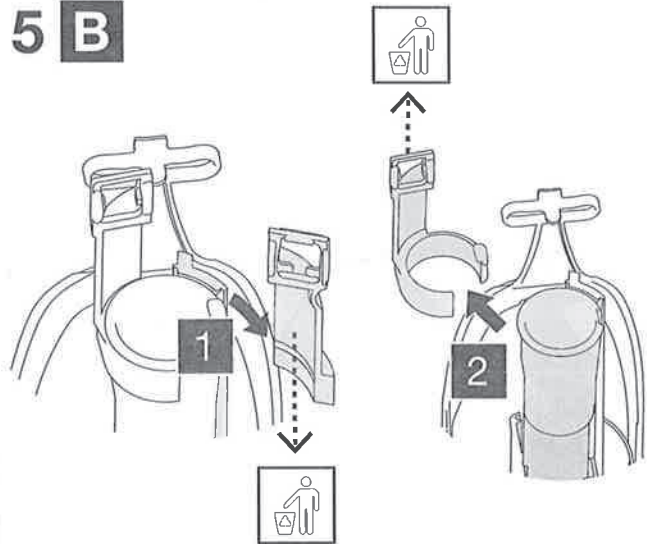

6 A

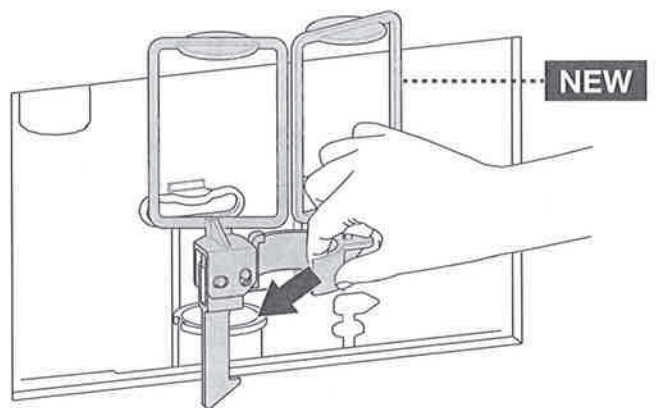

6 B

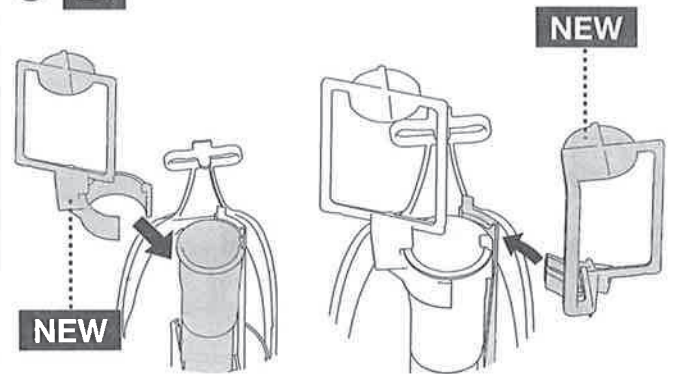

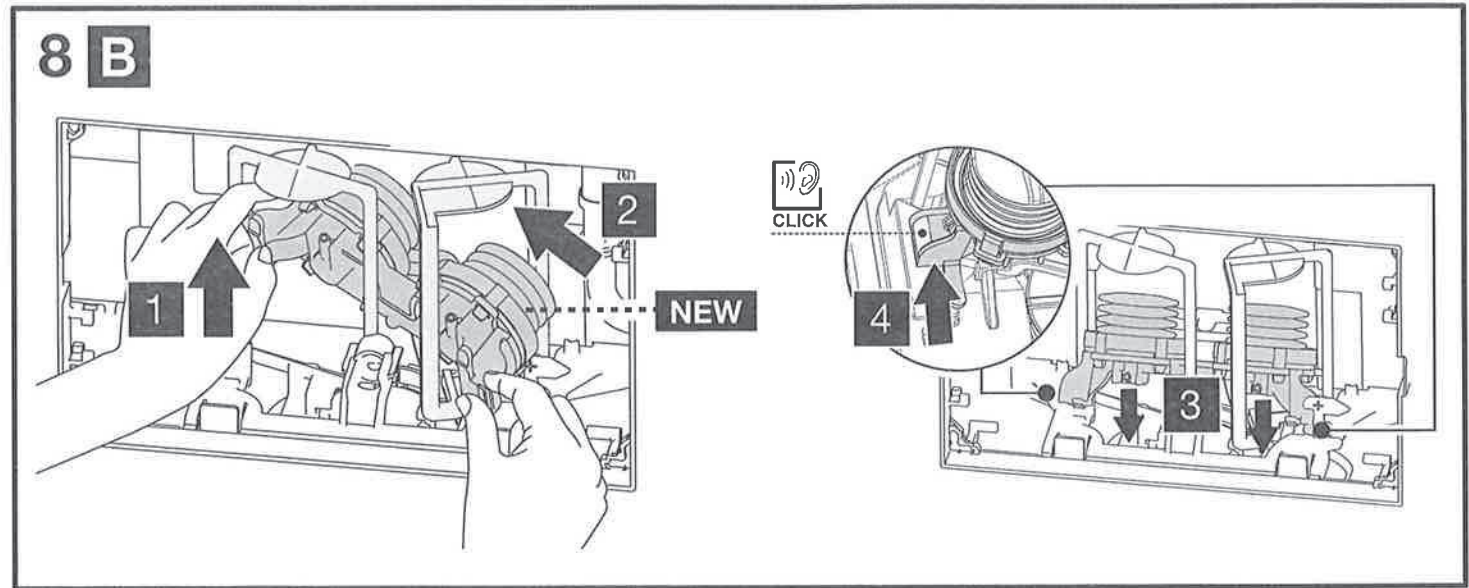
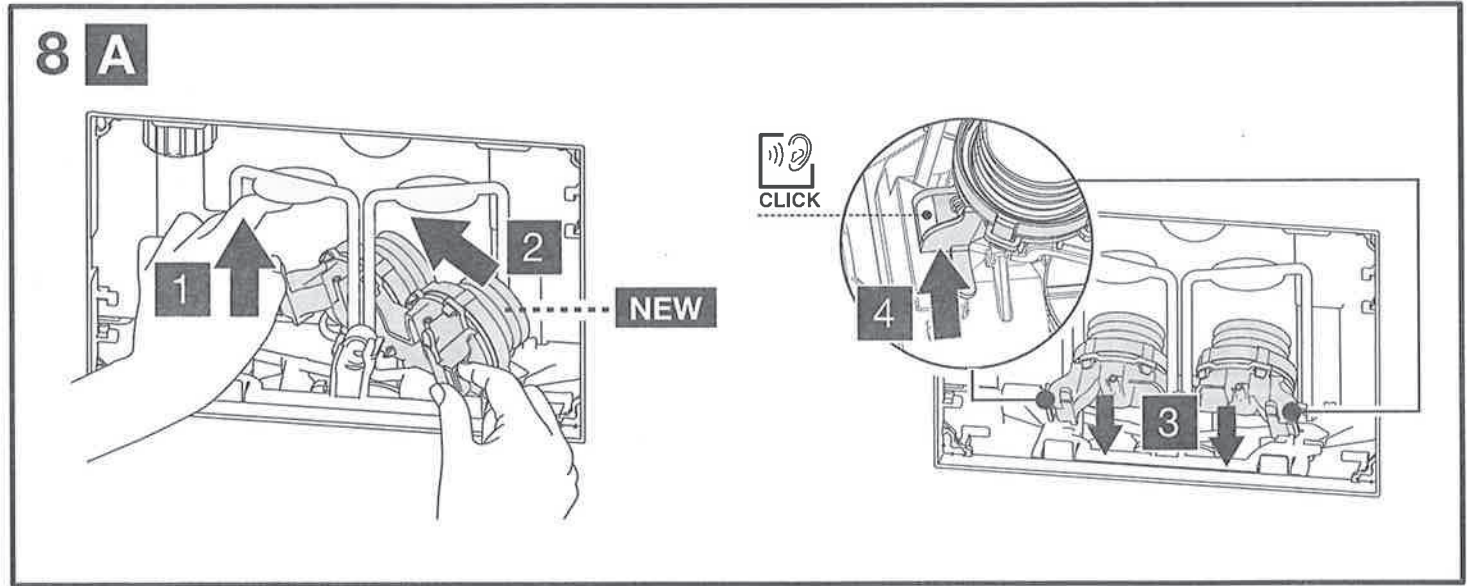
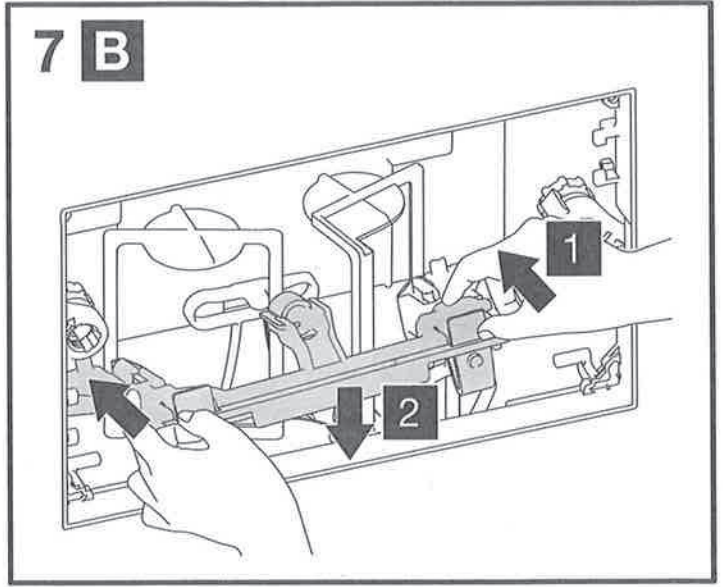
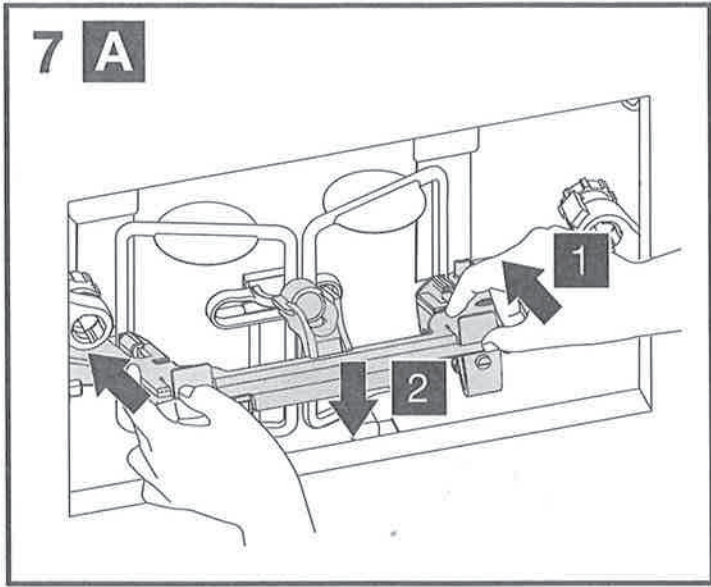

CONVERSION KIT

PNEUMATIC

